

# FIREBIRD

OIL FIRED BOILERS



## Combi Range



INSTALLATION  
COMMISSIONING  
SERVICING &  
USER INSTRUCTIONS

THIS MANUAL MUST  
REMAIN WITH THE  
HOUSEHOLDER ON  
COMPLETION OF  
INSTALLATION



# CONTENTS

## FOREWORD

### 1. INTRODUCTION

Health & Safety  
Fuel Spillage  
First Aid

### 2. TECHNICAL SPECIFICATIONS

2a Boiler Dimensions  
2b Boiler Specifications & Recommendations Etc.  
2c Oil Burner Performance Specification  
2d Boiler control panel wiring diagram  
2e & f Riello oil burner specification & technical details  
2g Control panel layout

### 3. OPERATING INSTRUCTIONS

3a Boiler controls  
3b Operating procedure  
3c Burner lock out  
3d Boiler operation & control

### 4. INSTALLATION

4a Standards & Regulations  
4b Positioning Boiler  
4c Flue Systems  
4d Boiler siting regulations & Standards  
4e Ventilation and Combustion Air  
1. Conventional Flue  
2. Balanced Flue  
4.f Domestic Htc. & H.w. Systems electrical supply

### 5. OIL SUPPLY

5a Oil storage tank siting  
5b Flexible oil pipe(s)  
5c Single pipe system  
5d Two pipe systems  
5e Tigerloop single pipe systems

### 6. FLUE SYSTEMS

6a Important notice  
6b Balanced flue systems  
6c Concentric flue systems

### 7. COMMISSIONING

7a Procedures  
7b Handing over

### 8. SERVICING

8a Recommended service intervals  
8b The oil tank  
8c The boiler  
8d The Burner

## COMBI PART 2.

Sealed system & domestic hot water Page 31

## COMBI PART 3.

### 9. FAULT FINDING

### 10. SPARE PARTS

10a Riello burner parts illustration  
10b Plumbing parts illustration  
10c Plumbing parts description  
10d Boiler parts illustration  
10e Boiler parts description  
10f Control panel illustration  
10g Control panel description  
Commissioning record Page 48  
Service reports Page 49

# FIREBIRD

## FOREWORD

This instruction manual is produced for the reference and guidance of qualified installation engineers. EU legislation governs the manufacture, operation and efficiency of all domestic oil boilers. One effect of this will be that boilers and burners will require to be supplied as matched units tested and approved to OFTEC Standard OFS A100.

FIREBIRD Boilers are full manufacturing members of OFTEC (Oil Firing Technical Association for the Petroleum Industry) and are participating in its Boiler testing and approvals programme to comply with OFS A100 and EC Efficiency Directive.

***Boilers must be installed, commissioned and serviced by qualified and experienced OFTEC approved personnel (U.K. only). It should be noted that it is the responsibility of the installer to ensure that the boiler is properly commissioned. Failure to do so may invalidate the boiler guarantee and any extended warranty.***

***All appropriate OFTEC manuals and BS Standards should be studied and their requirements adhered to and used in conjunction with these instructions. This manual includes a list of some BS Standards and Building Regulations.***

OFTEC is conducting training and registration of engineers and this is to be commended, as reading of this manual alone for installation and servicing procedures cannot replace the critical advantage provided by training and years of experience.

## 1

## INTRODUCTION

The Firebird Combi Boiler Range is based on the 'S' Range Boilers. All boilers in the range are designed and manufactured to meet all the latest European standards and the thermal efficiency requirements of the Boiler (efficiency) Regulations 1993. All Boilers can be fitted to a conventional flue or easily adapted to a room sealed unit by using a Firebird matched balanced flue kit.

The control panel can be easily accessed by the simple removal of four screws, then this assembly can be pulled forward for access to components.

Clean combustion with kitchen-quiet operation is assured by a highly efficient matching pressure jet burner which produces very low NO<sub>x</sub> emissions. The Combi Range is a dedicated sealed system boiler having a 12 litre expansion vessel on the 50-70 and 70-90 models, on the 90-120 model there is a 14 litre expansion vessel, system filling kit and 3 bar safety valve all fitted within its cabinet.

A drain-off cock is fitted inside the boiler beside the burner and there are flow and return connections provided under top lid of the boiler for connection to the heating and hot water systems. As all servicing can be carried out from the front, the boiler may be fitted under a kitchen worktop.

The burner is factory set for use with kerosene 28 second class C fuel. However, **35 second gas oil may be used on a conventional flue installation, a oil pre-heater may be necessary.**

### GUARANTEE

- All Firebird oil Boilers have a 2 year comprehensive warranty which extends to 5 year on the boiler shell
- The Guarantee card must be fully completed and returned to firebird within 28 day's of installation.
- Consumable components, the nozzles and the oil hose are excluded.
- The terms laid down on the Guarantee must be adhered to.

**NOTE: Some Firebird boilers are suitable for conversion to gas. Conversion must only be undertaken by Firebird approved gas technicians using a Firebird supplied conversion kit suitable for the particular boiler.**

# FIREBIRD

# 1

## HEALTH & SAFETY INFORMATION

Under the Consumer Protection Act 1987 and Section 6 of the Health and Safety Act 1974, we are required to provide information on substances hazardous to health.

### INSULATION AND SEALS

Ceramic Fibre, Alumino - Silicone Fibre material are used for boards, ropes and gaskets. Known hazards are that people may suffer reddening and itching of the skin. Fibre entering the eye will cause foreign body irritation. It may also cause irritation to the respiratory tract.

Precautions should be taken by people with a history of skin complaints or who may be particularly susceptible to irritation. High dust levels are only likely to arise following harsh abrasion.

Generally, normal handling and use will not give discomfort. Follow good hygiene practices, wash hands before consuming food, drink or using the toilet.

First Aid - Medical attention should be sought following eye contact or prolonged reddening of the skin.

The small quantities of adhesives and sealants used in the product are cured. They present no known hazards when used in the manner for which they are intended.



**THIS PRODUCT HAS BEEN DESIGNED TO THE FOLLOWING STANDARDS:**

#### EMC Directive

**(Electromagnetic compatibility) 89/336/EC**

Standards:

EN 61000-6-1: Electromagnetic Compatibility Generic Standard - Immunity for residential, commercial and light industrial environments. (Feb.2001)

EN 61000-6-3: Electromagnetic Compatibility Generic Standard - Emission standard for residential, commercial and light industrial environments. (Feb.2001)

#### LV Directive

**(Low voltage) 73/23/EEC**

Standard:

IEC 60335-1: Household and similar electrical appliances - Safety (May 2001)

#### Boiler Efficiency Directive 92/42/EEC

Standard:

BSEN 304: Oil boilers with forced draft burners.

# 1

## FUEL SPILLAGE

1. Switch off all electrical and other ignition sources.
2. Remove all contaminated clothing to safeguard against fire risk and skin damage. Wash affected skin thoroughly with soap and water and remove clothing to a safe well ventilated area and allow to air before cleaning.
3. Contain and smother the spill using sand or other suitable non-combustible material.
4. Do not allow fuel to escape into drains or water courses. If this happens, contact Fire Brigade and Local Water Authority.
5. Consult local Authority about disposal of contaminated soil.

# 1

## SAFETY

Safe use of Kerosene and Gas Oil.

These fuels give off a flammable vapour when heated moderately. Vapour ignites easily, burns intensely and may cause explosion. The vapour can follow along at ground level for considerable distances from open containers and spillages collecting as an explosive mixture in drains, cellars, etc.

Fuels remove natural oils and fats from the skin and this may cause irritation and cracking of skin. Barrier cream containing lanolin is highly recommended together with good personal hygiene.

Gas oil may also cause irreversible damage to health on prolonged or repeated skin contact.

Always store fuels in a properly constructed and labelled tank. Always handle fuel in open air or well ventilated space away from sources of ignition and refrain from smoking.

Always drain fuel using a proper fuel retriever, funnel or mechanical siphon. Never apply heat to a fuel tank, container or pipework. Never siphon fuel through tube by mouth. If accidentally swallowed contact doctor immediately and do **NOT** induce vomiting. Avoid inhaling fuel vapour as this can cause light headedness and seriously impair judgement.

# 1

## FIRST AID

If fuel is accidentally swallowed:-

- \* Seek medical attention immediately. Do NOT induce vomiting.

If fuel is splashed into eyes:-

- \* Wash out with running water for at least ten minutes and seek medical attention.

# 2 TECHNICAL SPECIFICATION

## 2-A Diagrams

### Combi Range Dimensions

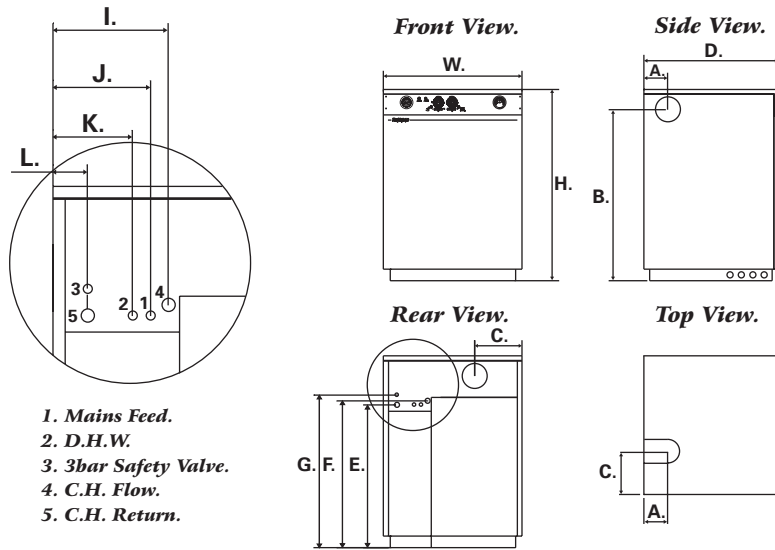

50-70 & 70-90				90-120			
H.	840mm	A.	155mm	H.	840mm	A.	155mm
W.	610mm	B.	750mm	W.	670mm	B.	750mm
D.	600mm	C.	190mm	D.	600mm	C.	220mm
		I.	210mm			I.	230mm
E.	640mm	J.	185mm	E.	640mm	J.	185mm
F.	650mm	K.	135mm	F.	650mm	K.	135mm
G.	695mm	L.	70mm	G.	695mm	L.	70mm

## 2-B Technical Specifications and Recommendations

**Heat Output** 50-120,000 Btu/Hr  
**Electricity Supply** 230 v - Boiler~50 Hz  
 To be fused at 5 amp

**System Pipe Connections (on boiler)**  
 Heating Flow 22 mm (28mm - 90-120,00 Btu/Hr)  
 Heating Return 22 mm (28mm - 90-120,00 Btu/Hr)  
 Mains Cold Water Boiler connection 15 mm  
 Hot Water delivery 15 mm  
 Safety pressure Relief Valve Outlet 15 mm  
 All Copper Tube connections: BS 2871 Copper Tube

Isolating ball valves are fitted to all boiler/system connecting pipework

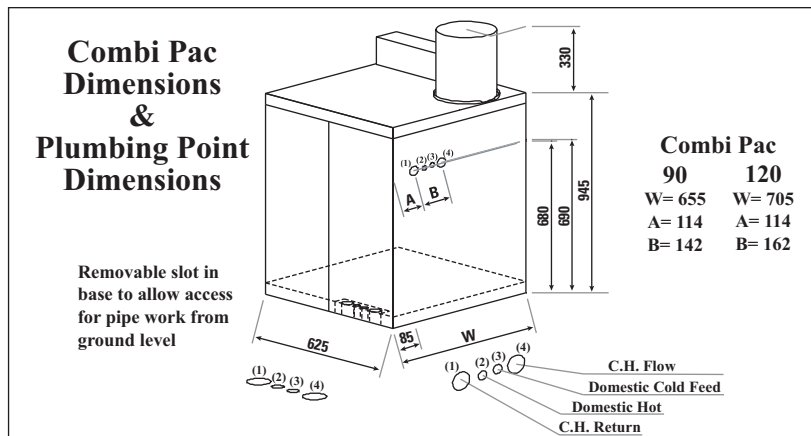

## 2 TECHNICAL SPECIFICATION

<b>Pressure Jet Oil Burner</b>	Riello RDB or Ecoflam Flair or Bentone Sterling
<b>Fuel</b>	Kerosene Class C2
Domestic Hot Water Plate Heat Exchanger	Giannoni Albion, SWEP or Alfa Laval
Circulating Pumps	Grundfos UPS 25/60
<b>Flue Pipe Connection</b>	
Conventional Flue Socket	To take tail piece for 4" (100mm) & 5" (125mm) S/S Flue Pipe
Balanced Flue Assembly	5" (125mm) Concentric Flue
Weight (Dry) - Incl. Pallet	50-70btu's - 160 Kg 70-90btu's - 162 Kg 90-120btu's - 177 Kg
Water Content - Total	50-70btu's - 59 Litres 70-90btu's - 59 Litres 90-120btu's - 68 Litres
- Primary Tank	50-70btu's - 40 Litres 70-90btu's - 40 Litres 90-120btu's - 44 Litres
<b>Thermostats</b>	
Boiler Central heating Control (Adjustable)	65°C - 85°C
Boiler Safety Limit	110°C
Tank (DHW)-Fixed	78°C
EA-Fixed	87°C
Over-run-Fixed	93°C
Boiler integral Expansion Vessel nominal capacity	12 & 14 Litres pre-charged to 1 Bar
<b>Heating System (Sealed)</b>	Fit in accordance with BS 7074 Part I, BS 5449, OFTEC Standards, etc.
Max. Operating Pressure	2.5 Bar (Follow all BS & OFTEC Standards)
Max. System Pressure (Cold)	1.5 Bar
Min. System Pressure (Cold)	0.5 Bar + 0.3 Bar
Boiler Test Pressure	4.5 Bar
Safety Valve Operating Pressure	3 Bar
Heating System Pressure Gauge (mains supply excepted)	0 - 6 Bar Range
Flue Draught Req'd. (Conventional Flue)	Min: 0.040 In WG Max: 0.15 In WG
Water side resistance-10°C Diff	26.8 ins WG
-20°C Diff	8.6 ins WG
Mains Water Supply Pressure	Up to 10 Bar. (Fit pressure reducing valve as necessary)
<b>Mains Water Supply</b>	
Limescale excess - when over 150/200 ppm	Consult Water Authority Fit appropriate scale reducer Also refer to Page 35

### Domestic Hot Water Guide Performance

- 50-70,000 Btu's - 120 Litres at 40° Δt at 12 Litres per minute**
- 70-90,000 Btu's - 120 Litres at 40° Δt at 14 Litres per minute**
- 90-120,000 Btu's - 120 Litres at 40° Δt at 18 Litres per minute**

# FIREBIRD

## 2 TECHNICAL SPECIFICATION

### 2-C Burner Settings Firebird Boiler Range Kerosene Using RDB Range Of Burners (K).

Variations in nozzle throughput, flue type & draught, oil viscosity etc. may give results differing from these laboratory performance figures.

Range	Burner	Head Type	Fuel	Nozzle	P.P.	Air Shutter Head		CO2	Fg.	Smoke No.
50,000	Riello RDB 1.	T1	K	.5 80'H	7 Bar	2.4	-	11.5	190	0-1
60,000	Riello RDB 1.	T1	K	.5 80'H	10 Bar	3.9	-	11.5	200	0-1
70,000	Riello RDB 1.	T3	K	.6 80'H	8 Bar	4.25	-	11.5	210	0-1
70,000	Riello RDB 1.	T3	K	.6 80'H	8 Bar	4.25	-	11.5	190	0-1
80,000	Riello RDB 1.	T3	K	.6 80'H	9.5 Bar	4.8	-	11.5	195	0-1
90,000	Riello RDB 1.	T3	K	.75 80'S	8 Bar	6	-	11.5	210	0-1
90,000	Riello RDB 2.	T3	K	.75 80'S	8 Bar	6	-	11.5	190	0-1
110,000	Riello RDB 2.	T3	K	1.00 80'S	7 Bar	2.6	-	11.5	190	0-1
120,000	Riello RDB 2.	T3	K	1.00 80'S	9 Bar	3.5	-	11.5	190	0-1

The above performance figures are based on ideal laboratory test conditions.

Air shutter settings above may need to be revised to take into consideration difference in resistances between conventional and balanced flue installations. Use flue gas analyser to achieve optimum results.

### 2-D Wiring Diagram Combi Range

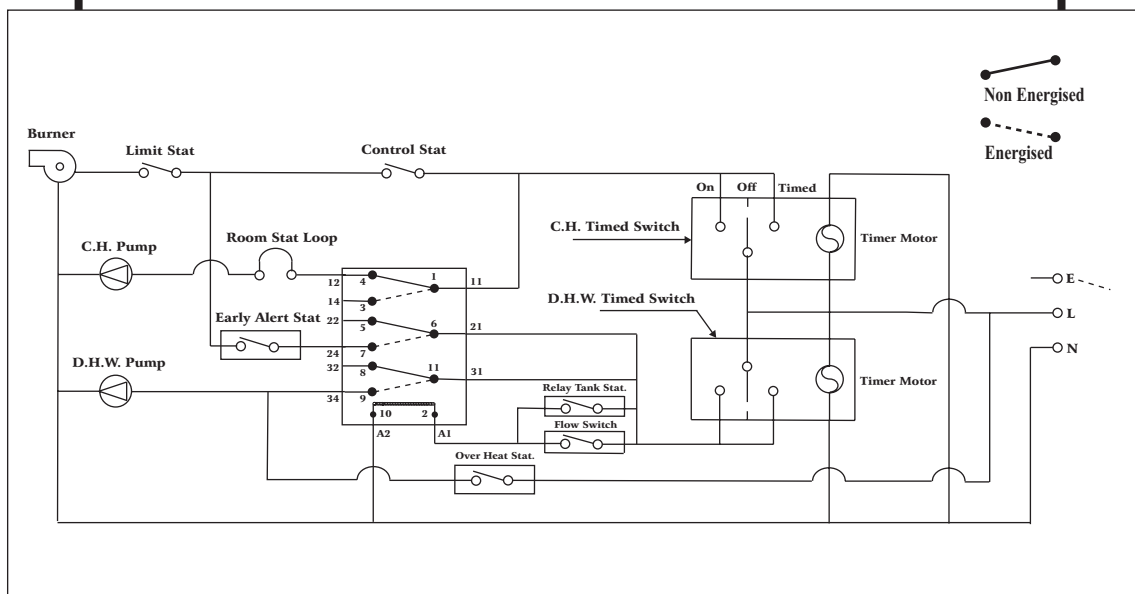

**FIREBIRD**

## 2-D Wiring Diagram Combi Range

See sticker on boiler for  
Coloured Wiring Diagram

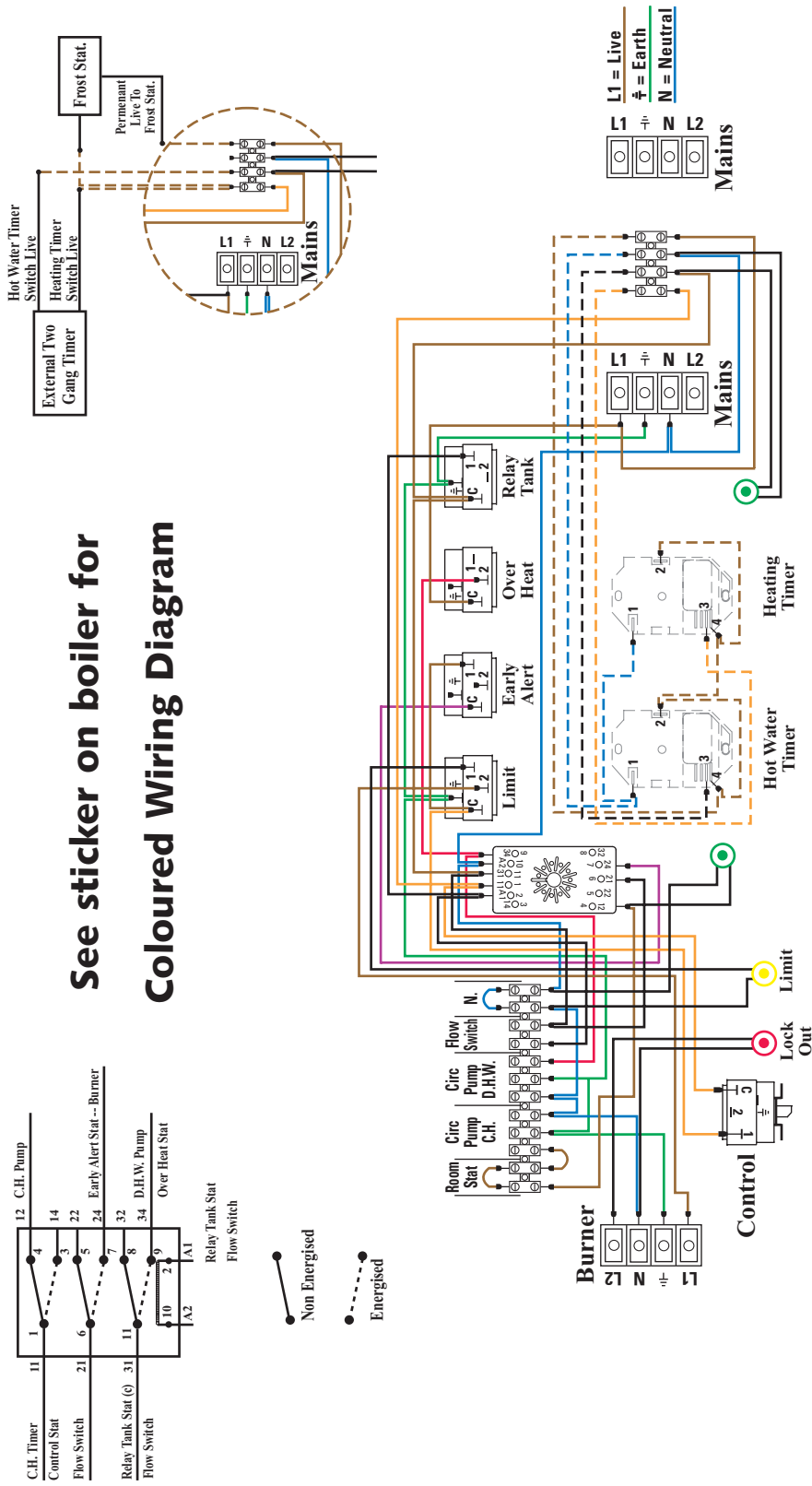

# 2 TECHNICAL SPECIFICATION

## 2-E&F Riello Burner Specification

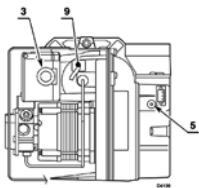

### Burner Description

One stage kerosene and oil burner.

In case of BF applications the intake air temperature must not be over 70C

The burner meets protection level of IP 40, EN 60529.

Burner with CE marking in conformity with EEC directives: EMC 89/336/EEC, Low Voltage 73/23/EEC, Machines 98/37/EEC and Efficiency 92/42/EEC.

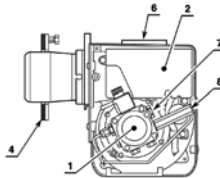

### Burner Equipment

- Flange with insulating gasket..... No.1
- Screw and nut for flange..... No.1
- Grill (CF Application)..... No.1
- Bolts for flange to be fixed to boiler..No.4
- Hexagonal Key..... No.1
- Screw of by-pass pump..... No.1
- Flexible oil pipe with nipple..... No.1

- 1. Pump
- 2. Control-box
- 3. Reset button with lock-out lamp
- 4. Flange with insulating gasket
- 5. Air damper adjustment screw
- 6. Snorkel (BF)
- 7. Pump pressure adjustment screw
- 8. Pressure gauge port
- 9. Photoresistance

### HYDRAULIC SYSTEMS

#### WARNING:

The pump is designed to allow working with one pipe. In order to obtain two pipes working it is necessary to unscrew the return plug (2), screw the by-pass screw (3) and connect return flexible hose. (See fig. 5).

In the two pipes systems, before starting the burner make sure that the return pipe-line is not clogged. An excessive back pressure would cause the damage of the pump seal.

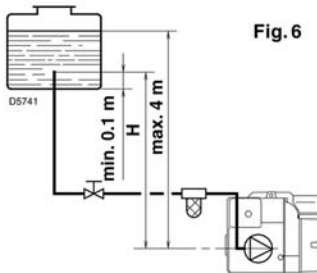

H meters	L meters	
	I. D. 8 mm	I. D. 10 mm
0.5	10	20
1	20	40
1.5	40	80
2	60	100

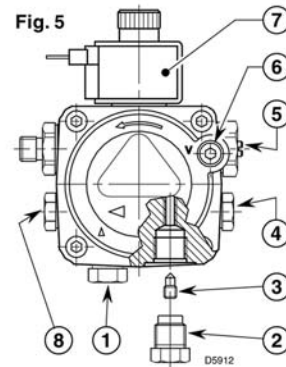

- 1 - Suction line
- 2 - Return line
- 3 - By-pass screw
- 4 - Gauge connection
- 5 - Pressure adjuster
- 6 - Suction gauge connection
- 7 - Valve
- 8 - Auxiliary pressure test point

#### PRIMING PUMP:

On the system in fig. 6 it is sufficient to loosen the suction gauge connection (6, fig. 5) and wait until oil flows out.

On the systems in fig. 7 and 8 start the burner and wait for the priming. Should lock-out occur prior to the arrival of the fuel, await at least 20 seconds before repeating the operation.

The pump suction should not exceed a maximum of 0,4 bar (30 cm Hg). Beyond this limit gas is released from the oil. Oil pipes must be completely tight.

In the vacuum systems (fig. 8) the return line should terminate within the oil tank at the same level as the suction line. In this case a non-return valve is not required. Should however the return line arrive over the fuel level, a non-return valve is required. This solution however is less safe than previous one, due to the possibility of leakage of the valve.

H meters	L meters	
	I. D. 8 mm	I. D. 10 mm
0	35	100
0.5	30	100
1	25	100
1.5	20	90
2	15	70
3	8	30
3.5	6	20

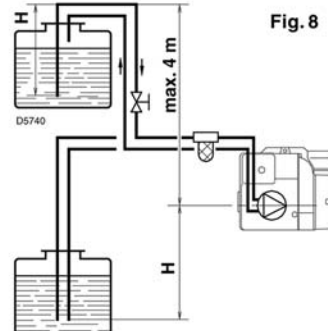
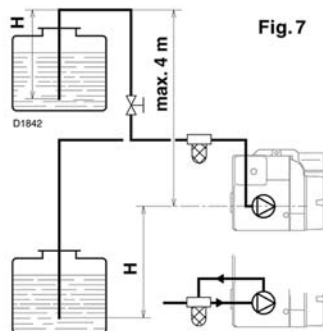

Check periodically the flexible pipes conditions.

Using kerosene, they have to be replaced at least every 2 years.

A metal bowl filter with replaceable micronic filter must be fitted in the oil supply pipe.

H = difference of level. L = Max. length of the suction line. I.D. = Interminal diameter of the oil pipes.





## 2 TECHNICAL SPECIFICATION

### 2-E&F Riello Burner Specification

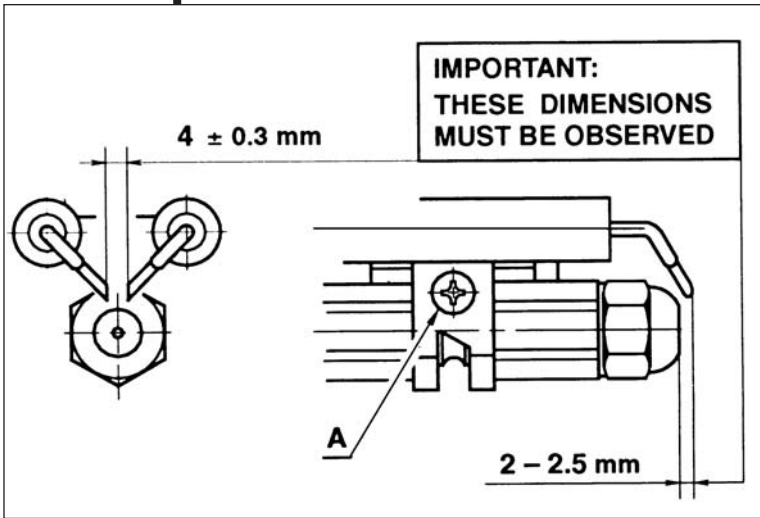

#### ELECTRODE SETTING

Riello RDB

#### Attention

Before assembling or removing the nozzle loosen screw (A) and move electrodes forward.

#### RIELLO BURNER START-UP CYCLE

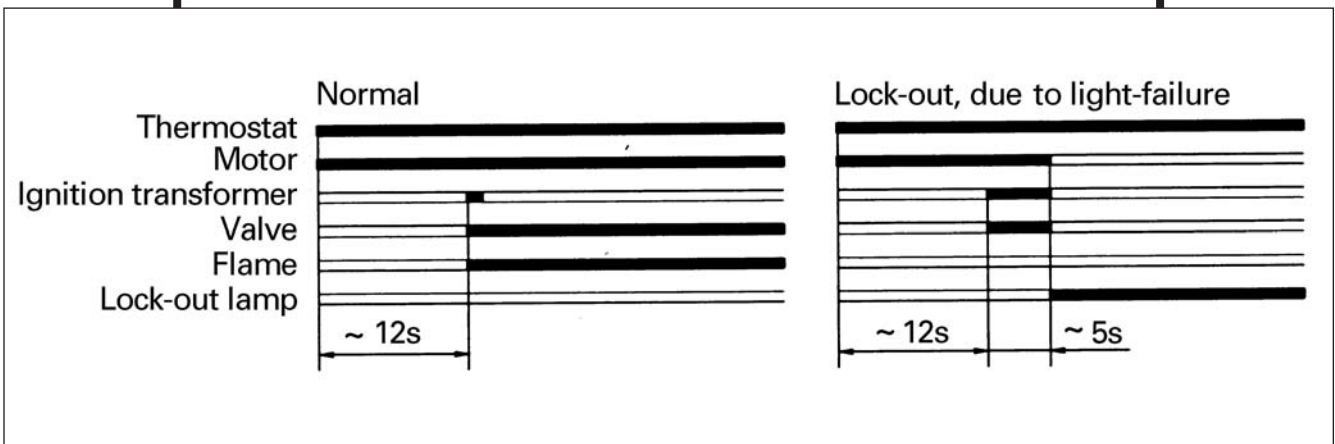

**NOTE:** Above information provided relevant to Riello RDB Burner. The Firebird 'S' Range has been tested and will operate equally efficiently using Ecoflam or Sterling Burners which may also be fitted as original equipment.

Refer to separate burner instructions booklet packed with boiler. Separate Riello Burner instructions are also included when these burners are fitted. Always consult these as variations in specification can occur from time to time which may not be included in this manual. Information is more complete in appropriate burner manuals.

# FIREBIRD

## 2 TECHNICAL SPECIFICATION

### 2-G Control Panel Layout

The control panel is at the top front of the boiler, there are four operational indicator lights on the front of the boiler. See diagram below

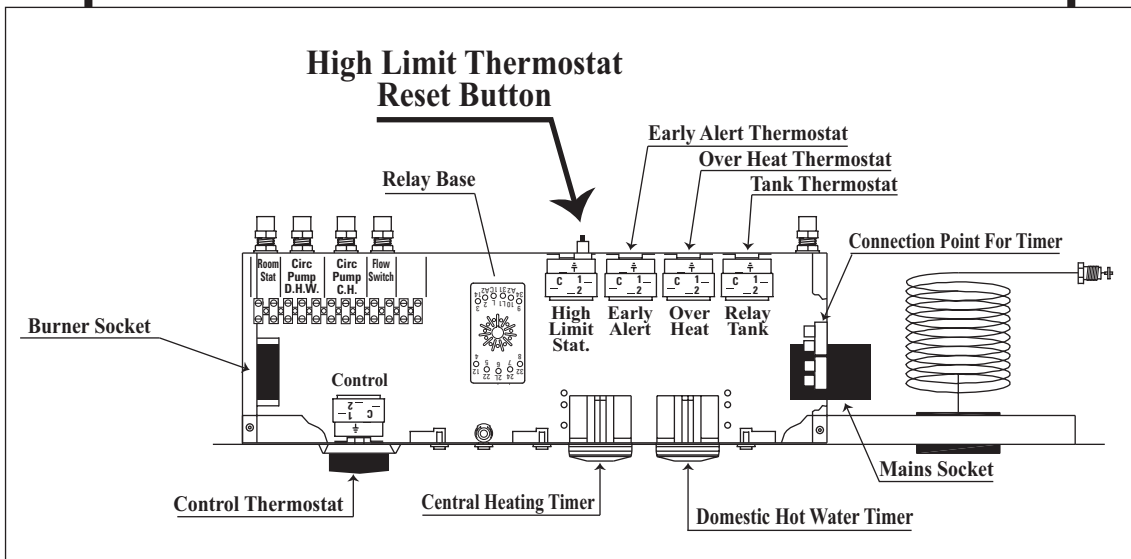
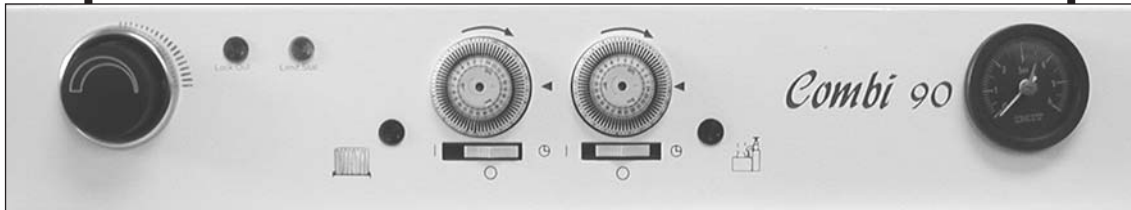

The control panel is designed for simplicity of use and is equipped with adjustable thermostat knob, optional time controls and limit thermostat reset button as shown above. It also has a built in system pressure gauge which is connected to the boiler and heating system water at the safety valve.

👉 When replacing make sure that each thermostat pocket receives correct phial by marking and noting carefully each phial and its correct pocket. 👈

# FIREBIRD

## 3 OPERATING INSTRUCTIONS

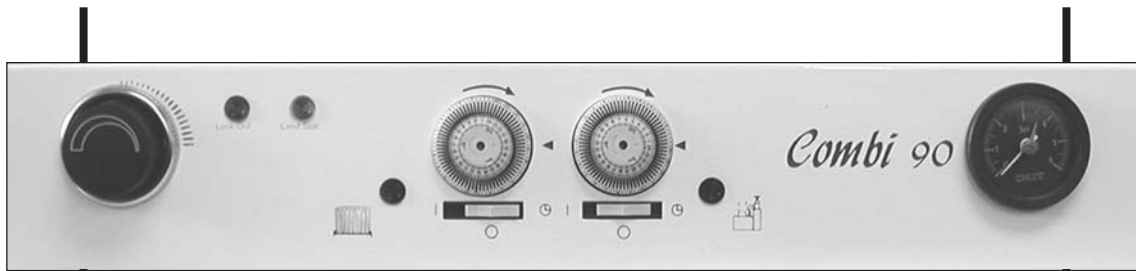

### 3-A Boiler Controls

Visible on the front boiler casing are

- Central Heating thermostat control.
- Time control - Domestic Hot Water. & Central Heating (optional).
- Limit-stat reset button (see diagram on page 11).
- Pressure Gauge

Also indicator lights. These are:

- Mains 'on'.
- Burner lockout.
- Domestic Hot Water
- Central Heating

### 3-B Operating Procedure

To start the boiler follow this sequence:

- Turn on fuel supply.
- Switch on power supply to boiler.
- Set the boiler thermostat to the required temperature.
- Set timer - Domestic Hot Water & Central Heating.



The central heating thermostat controls the boiler **when in central heating mode only**, thus maintaining the required boiler water temperature output for central heating.



**Domestic hot water temperature** is controlled by separate non adjustable thermostat, plus thermostatic mixing valve. **See page 15.**

Safe operation is also maintained by the burner control system which provides the required ignition and shut off sequence.

If the optional timer controls are fitted this will automatically switch the boiler off and on when **central heating and Domestic Hot Water** is required.

The boiler can be turned off by any of the following means:

- Turn both timer switches to OFF.
- Turn OFF the mains electrical supply to the boiler.

**WHEN SERVICING ALWAYS SWITCH OFF THE MAINS SUPPLY TO THE BOILER**

# FIREBIRD

## 3 OPERATING INSTRUCTIONS

### 3-C Burner Lockout



To reset when Lock-out light shows:  
Press glowing reset button on burner control box.

Reset Button  
Inside Burner Box

The boiler is factory fitted with a burner control box lockout safety feature which operates automatically if a fault occurs in the burners operation. Should this occur, the **RED** light on the front of the boiler control panel - See diagram on previous page - will illuminate and its cause must be investigated. This could be caused by:

- A. An interruption in the fuel supply. (Eg. empty oil supply tank)
- B. An electrical supply fault.
- C. A fault with the burner or its safety control system.
- D. The failure of a component. (Eg. photo cell)
- E. Worn or dirty oil nozzle.

Before attempting to restart the boiler the front panel and the burner cover should be removed and a visual check made for any obvious problems such as oil leaks, loose connections etc.

#### **ENSURE OIL TANK CONTAINS CORRECT GRADE FUEL.**

#### **To restart the boiler**

1. Press reset button (see diagram above)
2. Ensure that the boiler thermostat, time switch (if fitted) and any external controls connected to the boiler are set to call for heat.
3. Check that the oil supply valves are open and that there is sufficient oil in the tank.
4. Check that the burner lockout light is unlit and with the 'MAINS ON' the boiler will be ready to commence its start sequence.

#### **Servicing**

The boiler requires servicing on an annual basis to ensure it maintains its efficiency, continues to perform reliably and as a regular check on its built-in safety features.

It is important that servicing should be conducted by a competent engineer, one who is OFTEC trained and registered.

Please note: As a pre-heater kit maybe required to be fitted to the burner when using 35-second gas oil (only allowed on conventional flue applications) this means that annual servicing is usually sufficient - **although more regular servicing may be required depending on use.**

## 3 OPERATING INSTRUCTIONS

### 3-D Boiler Operation and Control

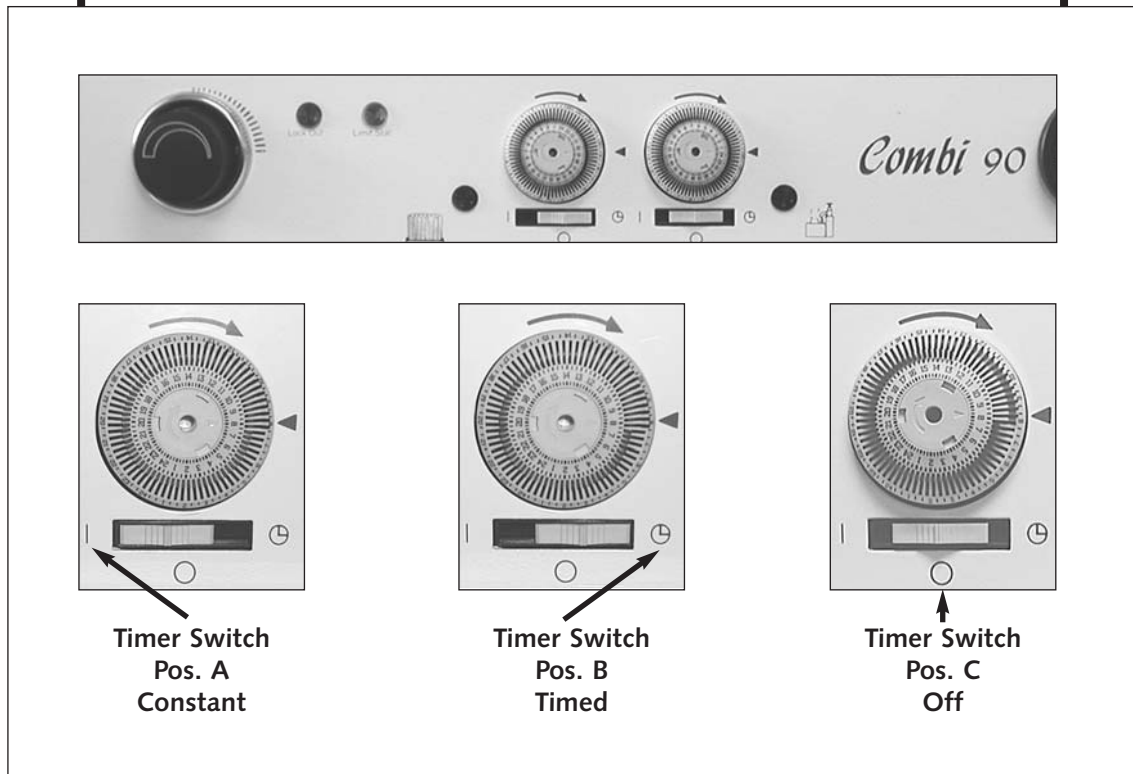

### Boiler Operation and Control

Domestic hot water production cycle commences once the timer has been set and switched on. If boiler and system are cold allow 20 - 30 minutes for domestic hot water heat store to reach working temperature. Central heating is controlled by setting the time switch - also located on this panel. The boiler control system always gives priority to domestic hot water production by automatically overriding the central heating mode as necessary. The interruption to central heating lasts only as long as the demand for hot water continues. This has no significant effect on the heating circuit. Once hot water demand has ceased the boiler will automatically return to central heating mode if there is a demand. When hot water only is required turn central heating timer switch to 'off'.

If alternative programmer is used then refer to separate programmer instructions.

By request Combi Boilers are available with built-in timers.

# FIREBIRD

## 3 OPERATING INSTRUCTIONS

### Programming Guide

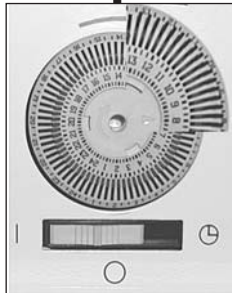

#### SETTING UP

The outer dial should be set to the current time. Rotate the dial slowly in a clockwise direction, until the correct hour is aligned with the arrow head printed on the dial. Note that the outer dial is printed with the 24 hour clock -

8:00 a.m. = 8 on the dial. 8:00 p.m. = 20 on the dial.

**Do not attempt to rotate the dial in an anti-clockwise direction.**

#### PROGRAMMING SWITCHING TIMES

Set all tappets between the on and off times required, to the outer edge of the dial (see figure 1). E.g. to set on at 8:00 a.m. - Off at 1:00 p.m. push tappets between dial numbers 8 and 13 to outer edge of dial. Set any other required switching times in a similar manner.

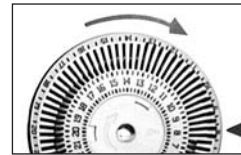

#### MANUAL SWITCH

Manual switch operation: The manual switch will provide Fixed On / Fixed Off / Auto control, thereby allowing manual control of the switched output without disrupting the timed (tappet) settings. Please refer to the illustration above.

The slide switch can be set in one of the three positions available 'on' and 'off' are fixed selections - the timer will remain in the on or off condition until you next use the manual switch to change the setting. 'auto' is the normal position for the switch, allowing control to be governed by the tappet settings - in accordance with 'programming switching times' above

### Domestic Hot Water Operation

Hot water is available on demand by turning on a hot tap. This activates the flow switch which powers the domestic hot water pump ensuring that all boiler hot water is diverted to the domestic heat exchanger which heats the incoming mains water to give instant mains pressure hot water.

Hot water is then mixed with mains cold water by a thermostatic mixing valve set to ensure that it does not exceed 65°C. This is shown in accompanying diagrams - Item No. 6.

The burner may continue to run after hot water draw off has ceased - to ensure the pre-set temperature is restored in the heat store. This may also occur at any time if the control system senses that there is a need to replenish the heat store, i.e. if there has been natural temperature drop in heat store during long periods of low demand for domestic hot water.

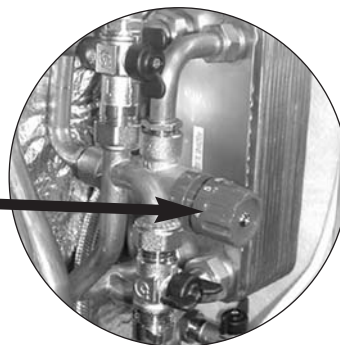

# FIREBIRD

### 4-A Standards & Regulations

To ensure the highest standards of installation & safety, it is important that the boiler be installed in compliance with the following regulations where applicable.

All **CURRENT** editions of the appropriate Building Regulations:-

**Part G & J England & Wales**  
**Part F, Section III Scotland**  
**Part L Northern Ireland**  
**Part J Republic of Ireland**

BS 5410 Part 1 1997. Code of practice for Oil Firing Installations.

BS 799 Part 5 1987. Specification for Oil Storage Tanks.

BS 4876 1984. Performance requirements for oil burning appliances.

BS 5449 1990. Specification for Forced circulation hot water central heating systems for domestic premises.

BS 7074 Part 1 1989. Application, selection and installation of expansion vessels and ancillary equipment for sealed water systems.

BS 5446 1990. Installation of hot water supplies for domestic purposes.

BS 7593 1992. Code of Practice for treatment of water in heating systems.

BS 715 1989. Metal flue pipes, fittings, terminals and accessories.

BS 1189 1989. Clay flue linings and flue terminals.

**BS 4543 part 3 1990. Factory made insulated chimneys for oil fired appliances.**

BS 6700. Design, installation, testing and maintenance of Services supplying water.

BS 7671.

Current IEE Regulations.

Local Water Undertaking Byelaws.

The Control of Pollution (Oil) Regulations.

In addition, **the work must comply with OFTEC Installation Requirements for oil fired boilers and oil storage tanks.**

The installer should also be aware of his/her responsibilities under The Health and Safety at Work Act. The interests of safety are best served if the boiler is installed and commissioned by a competent engineer, OFTEC trained and Registered or trained to other recognised standards.

It is the responsibility of installer and everyone concerned with any aspect of installation to ensure that all **applicable standards and regulations are fully adhered to.**

OFTEC also publish excellent guides including:-

- Safe Working Practices for Oil Firing Technicians'
- OFTEC Technical Book Three (Installation requirements for Oil Fired Boilers and Oil Storage Tanks)
- OFTEC Technical Book Four (Domestic Heating Systems) and it is recommended that these should be adhered to.

Copies of British Standards may be purchased direct from:

**BSI (Customer Services), 389 Chiswick High Rd.,  
 London W4 4AL**

**Tel.: 0181-9967002 Fax: 0181-9967001**

International and EC Standards are also available from above

OFTEC Publications are available from:-

**OFTEC,  
 Oil Firing Technical Association,  
 Foxwood House, Dobbs Lane,  
 Kesgrave, Ipswich.  
 IP5 2QQ**

**FIREBIRD**

**4-B****Positioning Boiler**

Ensure that adequate clearance is available for making the water and flue connections.

As the boiler is serviced from the front, no headroom clearance is necessary but a clearance of 750mm must be available at the front of the boiler.

No special hearth is required as the boiler is fully insulated, but the floor must be level and capable of supporting the weight of the boiler and its water content.

Sound levels must also be a consideration. Whilst the Firebird Combi Range are one of the quietest boilers on the market, some householders are particularly sensitive and the following points should be considered:

1. Tiled surfaces in a small room will amplify noise - particularly if the wall construction is hollow.
2. If a conventional flue passes through a bedroom it is capable of transmitting noise.
3. Low level balanced flue terminals can produce exhaust noise on the outside terminal and this should be considered when siting near adjacent property.
4. Firebird do not recommend the use of a low level flue's on white cased indoor boilers.
5. The Firebird low level concentric flue kit has been specifically designed for Firebird's indoor boilers. The use of third party low level flue kits is not recommended and may affect its warranty.

### 4-C Flue Systems

#### IMPORTANT

Because of the improved efficiencies of boilers under E.U. Efficiency requirements and OFS A100 Standard, it is necessary to pay extra special attention to flues and chimneys. The improved efficiency figures achieved by modern oil boilers are attained by using more of the heat (higher temperatures) heretofore allowed into flues and chimneys. This previously wasted heat helped to keep bad and poorly operating and often uninsulated flues and chimneys from condensing and causing problems. Please be fully aware of this when replacing an existing boiler. An old and poorly operating flue may need to be replaced to take full advantage of improved efficiencies and to avoid flue gases condensing and appearing as white water vapour (pluming) at flue (chimney) outlet.

New flues and chimneys should be properly insulated and constructed to prevent condensation and draughting problems. Every individual concerned with any aspect of installation should be aware of the foregoing and should have full knowledge of and **work to European, National and Local Govt. Standards and Building and Installation Regulations.**

These manufactures instructions must not in any way be mis-interpreted as over-riding the above or any statutory regulations. It is absolutely essential that the boiler is properly installed so that **NO FLUE GASES** can enter the building at any time. Flue pipes should be safely sealed into the wall to prevent flue gases re-entering room or building. Refer also to page 23.

#### Conventional Brick Chimney With Liner

##### NOTE:

All brick chimney constructions must comply with current building regulations and BS 5410: Part 1. Insulated factory made chimneys should comply with BS 4543.

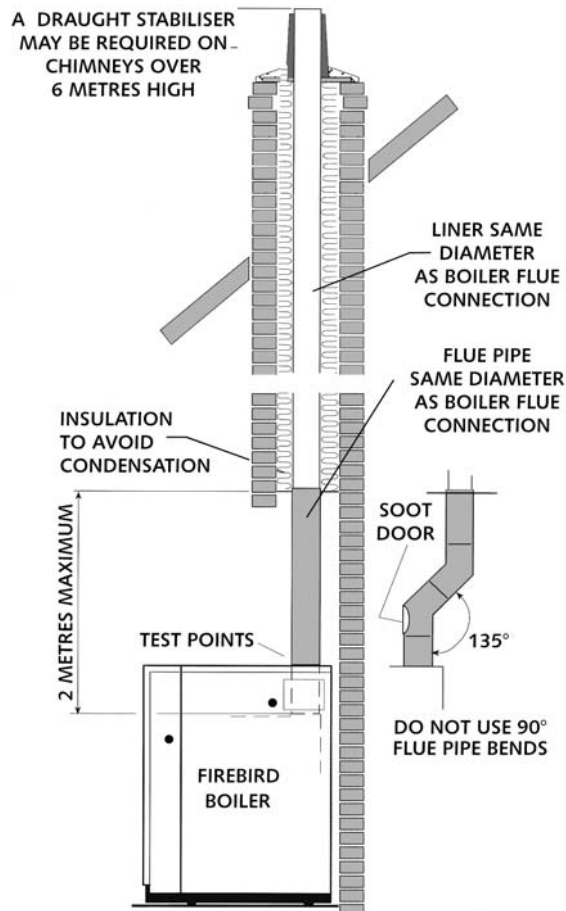

# FIREBIRD

## 4-D Balanced Flue Siting

- A. Below a gutter or sanitary pipework.
- B. Horizontal from opening, airbrick, window etc.
- C. Above ground or balcony level.
- D. Below eaves or balcony
- E. From an internal or external corner.
- F. From a terminal facing the terminal.
- G. From a surface facing the terminal.
- H. Vertical from terminals on the same wall.
- I. Horizontal from terminals on the same wall.

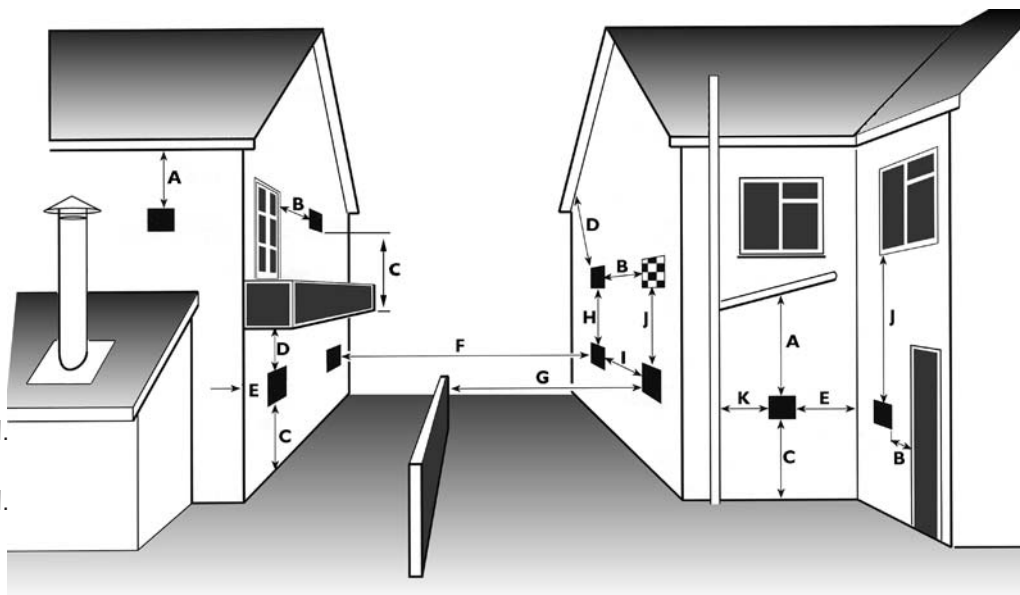

- J. Below an opening, airbrick, window etc.
- K. From vertical sanitary pipework.
- L. Vertical flue from wall.

Information supplied by



Book three Nov. 1997

See note at foot of page

- Notes:
1. The terminal should be positioned to avoid combustion products entering the building or accumulating in stagnant pockets around buildings.
  2. The terminal must be protected by a guard if it is less than 2 metres above ground level or in a position where any person has access to it (i.e. a balcony).
  3. A heat protection shield should be fitted if the terminal is less than 850mm from a plastic or painted gutter or less than 450mm from painted eaves.

## Building Regulations

	A	B	C	D	E	F	G	H	I	J	K
England & Wales 1991	-	600	-	-	600	-	-	-	-	600	-
Scotland 1990 Balanced*	600	-	600	600	600	600	600	1500	600	600	600
Low level*	1000	-	600	1000	600	600	600	1500	600	600	1000
Northern Ireland 1994	-	600	-	-	600	-	-	-	-	600	-
Republic of Ireland 1997	-	600	-	-	600	-	-	-	-	600	-

\*Where the terminal is within 1 metre of any plastic material, such material should be protected from the effects of combustion products of fuel. There are additional general requirements in most Regulations and Standards that the flue must be positioned so that it does not cause a nuisance and permits the dispersal of combustion products.

**NOTE:** The Buildings Regulations clearances shown above are **minimum** allowed. Account should also be taken of prevailing site conditions, as the above minimums may in certain circumstances need to be increased. If in doubt contact manufacturer for advice.

Always check for any Building Regulations amendments which may have been issued after the publication of this manual

**FIREBIRD**

# 4

## INSTALLATION

### 4-D Clearances advised by the British Standards for Open, Low Level Discharges and Balanced Flues fitted to Oil Fired Boilers

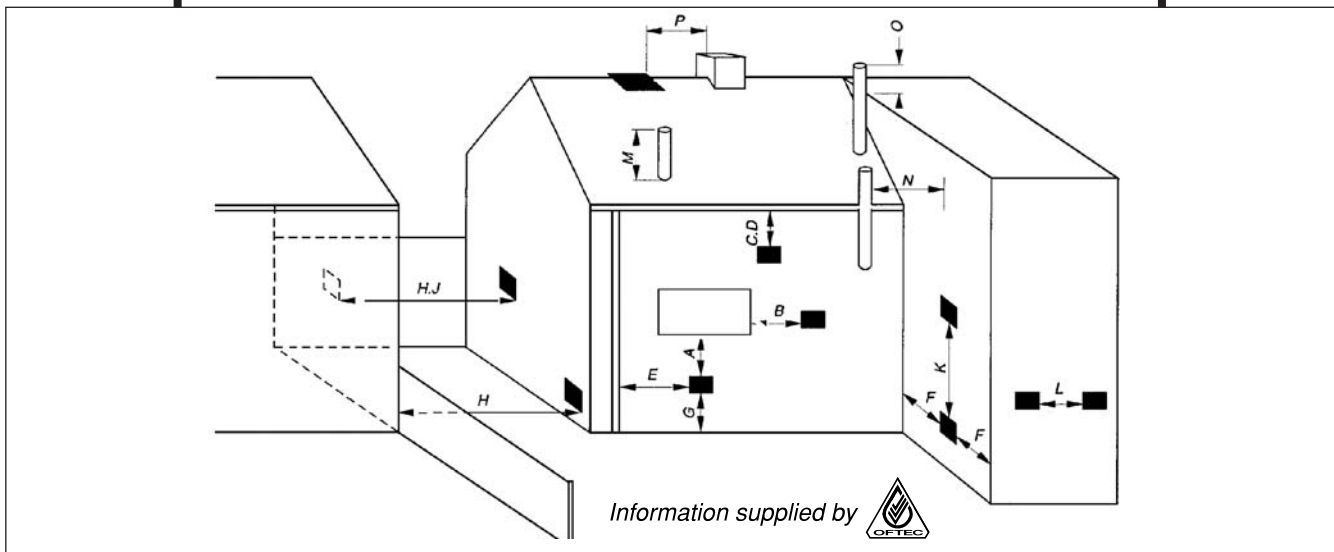

#### Minimum distances to terminals in millimetres as measured from top of the chimney or the rim of a low level discharge opening

A	Directly below an opening, air brick, window etc	600
B	Horizontally to an opening, air brick, window etc	600
C	Below a gutter, eaves or balcony with protection	75
D	Below a gutter or a balcony without protection	600
E	From vertical sanitary pipework	300
F	From an internal or external corner	300
G	Above ground or balcony level	300
H	From a surface or boundary facing the terminal	600
J	From a terminal facing the terminal	1200
K	Vertically from a terminal on the same wall	1500
L	Horizontally from a terminal on the same wall	750
M	Above the highest point of an intersection with the roof	600
N	From a vertical structure on the side of the terminal	750
O	Above a vertical structure less than 750mm from the side of the terminal	600
P	From a ridge terminal to a vertical structure on the roof	1500

#### These notes form an integral part of the information shown above.

1. Terminals should be positioned so as to avoid products of combustion accumulating in stagnant pockets around the building or entering into buildings.
2. Appliances burning Class D oil have additional restrictions.
3. Vertical structure in N, O and P include tank or lift rooms, parapets, dormers etc.
4. Terminating positions A to L are only permitted for appliances that have been approved for low level flue discharge when tested to OFS A100 or A101.
5. Terminating positions must be at least 1.8 metres distant from an oil storage tank unless a wall with at least 30 mins fire resistance and extending 300mm higher and wider than the tank is provided between the tank and the terminating position.
6. Where a flue is terminated less than 600mm away from a projection above it and the projection consists of plastic or has a combustible or painted surface, then a heat shield of at least 750mm wide should be fitted to protect these surfaces.
7. For terminals used with vapourising burners, a horizontal distance of at least 2300mm is required between the terminal and the roof line.
8. If the lowest part of the terminal is less than 2 metres above the ground, balcony, flat roof or other place to which any person has access, the terminal must be protected by a guard.

## 4-E Ventilation and Combustion Air

### 1. Conventional Flue Boilers

An adequate supply of **combustion and ventilation air** is essential for efficient and safe boiler operation and the openings for this should be positioned to cause least possible draught, **with no possibility of being accidentally blocked.**

Please note: The British Standard Code of Practice for Oil Firing BS5410: Part 1, requires a permanent air inlet opening of **550mm<sup>2</sup> per kW (above 5 kW)** of boiler rated output. (Note: 1kW = 3412 Btu/h).

Also, when the boiler is installed in a compartment or confined space, **ventilation** openings are required to ventilate and to avoid overheating in the boiler area.

### Combustion & Ventilation air supply for conventional open flue boilers

The figures shown are free areas of grilles in mm<sup>2</sup> per kW of appliance rating (output).

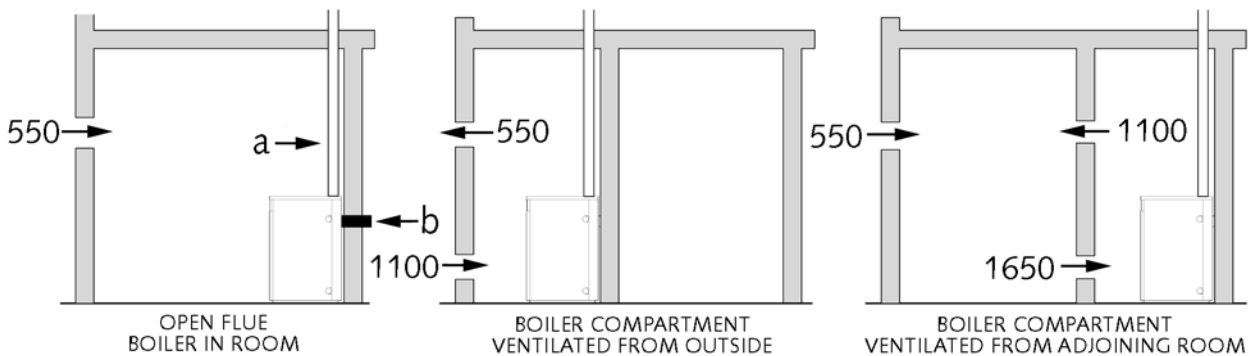

Conventional open flue (a) or open flue low level discharge (b)

Information supplied by 

FULL TEXT of both BS 5410 Part 1: 1997 and appropriate Building Regulations for each country should be obtained and fully applied

#### N.B. Please Carefully Note:

A. For boiler installations in domestic garages in Scotland, Part F of Building Regulations permits **only** Room Sealed appliances to be used (Ref. OFTEC Bk. Three May 1999 page 1 (18)).

B. Technical annex T1/127 to OFTEC Book Three, May 1999 page 2 (19) Para. 1, 2 states "In Scotland and the Republic of Ireland **only** Room Sealed Balanced Flue Appliances can be used in that location" (i.e. domestic garages).

#### Definitions

**Combustion Air** : Air required directly by boiler oil burner for combustion process.

**Ventilation Air** : Air required in room for ventilation, cooling, etc. and to promote a healthy living environment.

# 4

# INSTALLATION

## 4-E

### 2. Balanced Flue Boilers

The Firebird boiler may be set for Room-sealed balanced flue operation using a Firebird balanced flue kit and then does **not** draw **combustion air** from inside the room. **It is drawn from outside direct to burner by airpipe supplied with boiler.** Flue gases are expelled in the same way. However, if the boiler is installed in a **compartment** or **small room**, some **ventilation air** is necessary to maintain acceptable temperature in boiler area

**Balanced flue boiler in room (eg. kitchen) does not require individual ventilation.**

## BALANCED - FLUE BOILERS IN COMPARTMENTS

Information supplied by

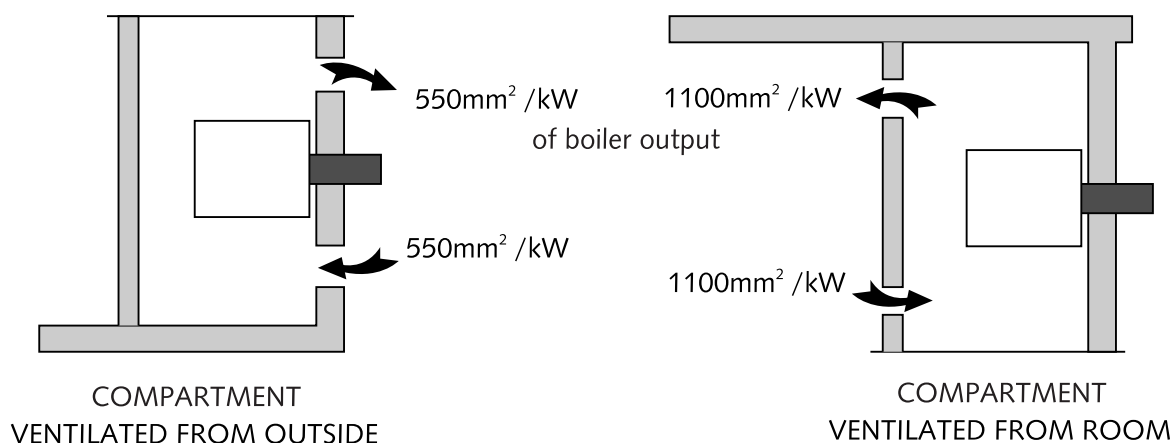

### 4-F Domestic Heating & Hot Water Systems

HVCA Codes of Practice and BS 5449: Part 1 "Forced Circulation Hot Water Systems" should be adhered to when installing the boiler. Refer also to Regulations and Standards listed on page 14.

#### Electrical Supply

The boiler and controls require 230V 1 phase 50Hz electric supply with a 5amp fuse.

**THIS APPLIANCE MUST BE EARTHED.**

A qualified electrician must carry out all electric wiring in accordance with current I.E.E Regulations and any local regulations which may apply.

The mains electrical supply must be taken from a double pole isolating switch with a 5amp fuse, positioned somewhere close to the boiler. Heat resisting cable must be used which can be routed into the boiler through the access provided on either side of the base.

Ancillary controls may be provided for with terminal connections in the control panel.

# FIREBIRD

The boiler burner is factory set to use 28-second kerosene. However, Gas oil 35-second can be used with a conventional flue installation if a PRE-HEATER is also fitted. Note: Gas Oil 35sec **may not** be used with a balanced flue installation.

If boiler location allows use of 35 sec. Gas Oil, pump pressure should be increased and air settings readjusted as necessary. **This adjustment should be carried out by qualified persons only.**

### 5-A Oil Storage Tank Siting

Consult OFTEC Manual

It is very unlikely that a fire should start from a domestic oil tank, however it does need to be protected from a fire which may originate in a building nearby. For this reason, the tank should be located at least 1.8 metres from any building and no closer than 760mm from any boundary. If it must be closer than 1.8 metres, the building wall should not have any openings other than ventilation openings. In addition, the wall should have a half hour resistance to an internal fire and extend 1.8 metres from any part of the tank.

A non-combustible radiation barrier is an alternative but this must meet the requirements of BS 5410 Part 1: 1994, "clause 28" Section 6.4.

Steel tanks must be mounted on brick or block piers with a waterproof membrane between the piers and tank.

Polyethylene tanks do not need pier supports and may be mounted on any flat surface which can support the weight of the tank and its contents. They also do not corrode and never require painting.

Oil storage tanks **should not be sited** close to boiler flue outlets.

Do not allow household waste or hot ashes container in vicinity of oil storage tank or boiler flue outlet.

### 5-B Flexible Oil Pipe(s)

A flexible burner oil hose is supplied with the boiler.

**Please note: A filter must not be fitted inside the boiler and all joints in the oil line must be oil-tight. Soldered joints are not permissible.**

**Before connecting to the boiler always flush the complete oil supply line and ensure that oil supply is completely clean and free of any dirt or foreign matter.**

### 5-C Single Pipe System

Where installations have the bottom of the tank above the oil burner, a single pipe system may be used. The oil burner should then be set for single pipe operation - See also manufacturers oil burner manual

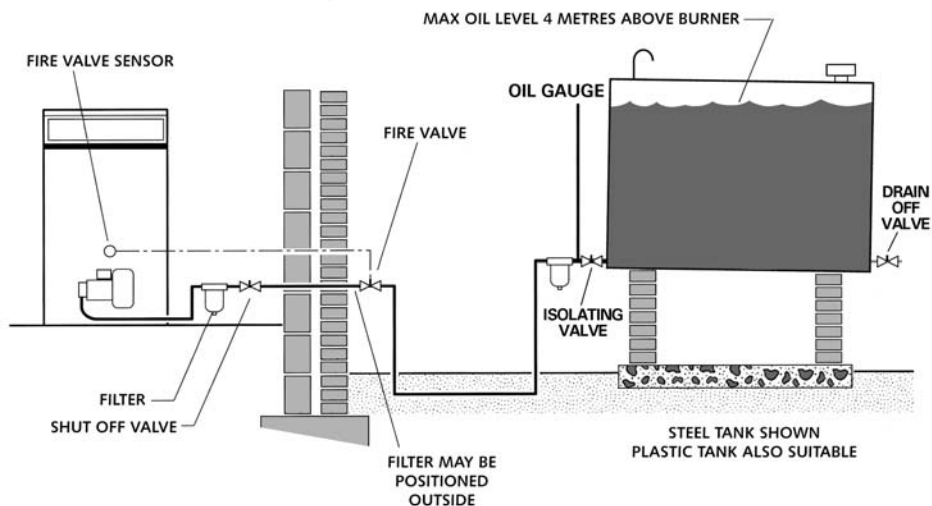

### 5-D Two Pipe Systems

Where installations have the bottom of the tank below the oil burner pump a two pipe system is required. Ensure that valves and filters are not fitted in the return line as this must be unobstructed at all times.

The oil burner pump should be set for two pipe operation as detailed in accompanying oil burner manufacturers manual, refer also to page seven of this manual - section 2E+F

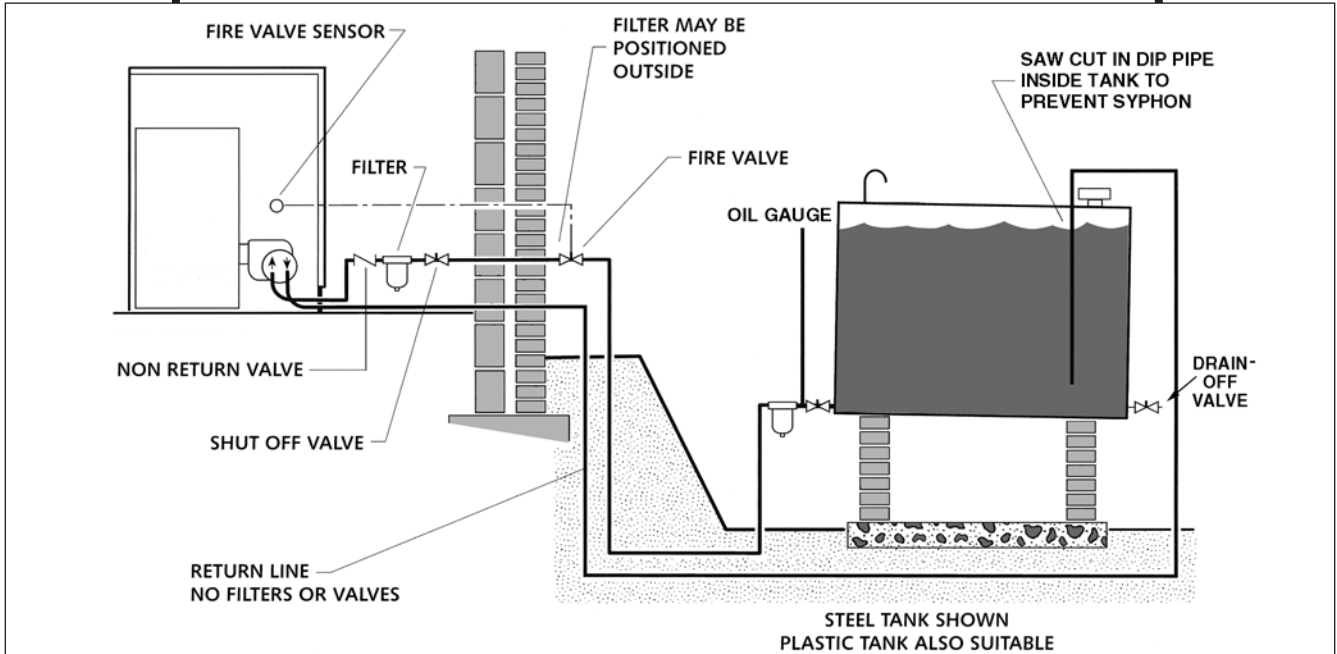

### 5-E Tigerloop Single Pipe Systems

**IMPORTANT:** The Tigerloop should not be fitted inside the dwelling - See drawing below and OFTEC manual book 3 page 2(10)

Where installations normally require a two pipe system but have long or impractical return line runs, a 'Tigerloop' De-aerator can be used which removes air from a single - pipe - lift oil feed. Higher lift heights can be achieved than are possible with conventional two pipe systems.

The oil burner pump should be set for two pipe operation.

Individual Tigerloop instructions must be implicitly followed.

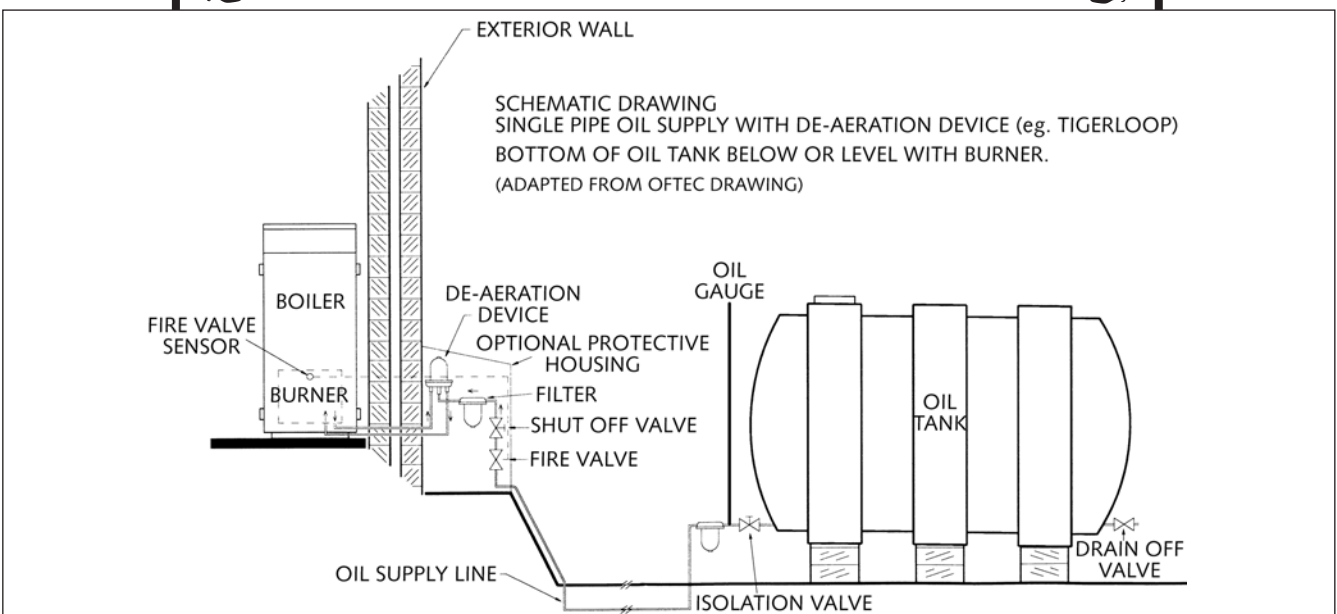

### 6-A Important Notice

Because of the improved efficiencies of boilers under E.U. Efficiency requirements and OFT A100 Standard, it is necessary to pay extra special attention to flues and chimneys.

The improved efficiency figures achieved by modern oil boilers are attained by using more of the heat (higher temperatures) heretofore allowed into flues and chimneys. This previously wasted heat helped to keep bad and poorly operating and often uninsulated flues and chimneys from condensing and causing problems. Please be fully aware of this when replacing an existing boiler. An old and poorly operating flue may need to be replaced to take full advantage of improved efficiencies and to avoid flue gases condensing and appearing as white water vapour (pluming) at flue (chimney) outlet.

New flues and chimneys should be properly insulated and constructed to prevent condensation and draughting problems. Every individual concerned with any aspect of installation should be aware of the foregoing and should have full knowledge of and work to **European, National and Local Govt. Standards and Building and Installation Regulations.**

These manufactures instructions must not in any way be mis-interpreted as over-riding the above or any statutory regulations. It is absolutely essential that the boiler is properly installed so that **NO FLUE GASES** can enter the building at any time. Flue pipes should be safely sealed into the wall to prevent flue gases re-entering room or building

Refer also to page 16.

#### PREPARING BOILER FOR CONVENTIONAL CHIMNEY/FLUE OPERATION

Before installing boiler in the above mode please ensure:

- A. That chimney flue is cleaned, draughting adequately, lined if necessary and not subject to downdraughts. **It is emphasised that boiler and flue should be connected properly in a manner which will not allow flue gases to enter room or building at any time from any part of the installation.**
- B. That adequate unrestricted air for combustion and ventilation is provided to room in which boiler is situated - see diagram pg.20 & 21.
- C. **That there is no extractor fan capable of causing negative pressure in boiler room resulting in burner malfunction and flue gases being drawn back into boiler room.**

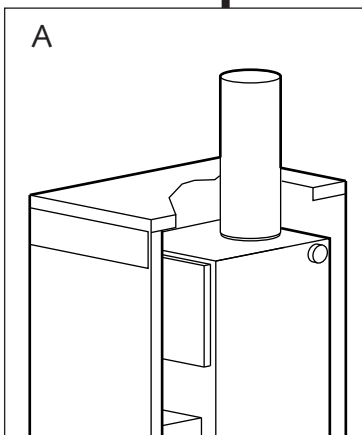

#### Conventional Flue Installations-

1. Remove blanking plate from top panel by pulling backwards.



2. Fit trim sleeve to flue pipe (if supplied).
3. Slide upwards and 'park' it out of the way
4. Fit flue pipe into boiler socket and properly seal with high temperature silicone mastic or non-cracking fire cement.
5. Fit white enamel top panel
6. Fit cut-out cover plate behind flue pipe (shown in diagram)



7. Slide trim sleeve down against top panel (If Supplied)

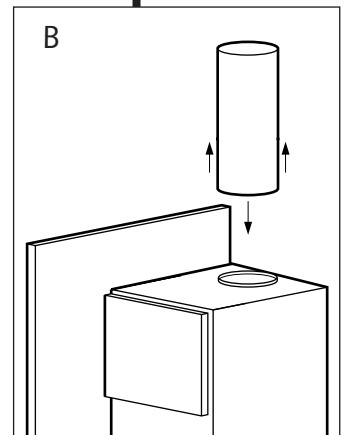

**ENSURE UNRESTRICTED AIR-SUPPLY TO BOILER ROOM.** No further adjustments are required for adequate combustion-air supply. Check burner operation when installation is completed, use burner **Combustion Analyser** to ensure correct performance.

Consult separate burner manual supplied with boiler.

# FIREBIRD

### 6-B Balanced Flue System

**IMPORTANT: THE INSTALLER MUST EXAMINE THIS ILLUSTRATION CAREFULLY BEFORE PROCEEDING WITH INSTALLATION.**

- Firebird do not recommend the use of a low level flue's on white cased indoor boilers.
- The Firebird low level concentric flue kit has been specifically designed for Firebird's indoor boilers. The use of third party low level flue kits is not recommended and may affect its warranty.

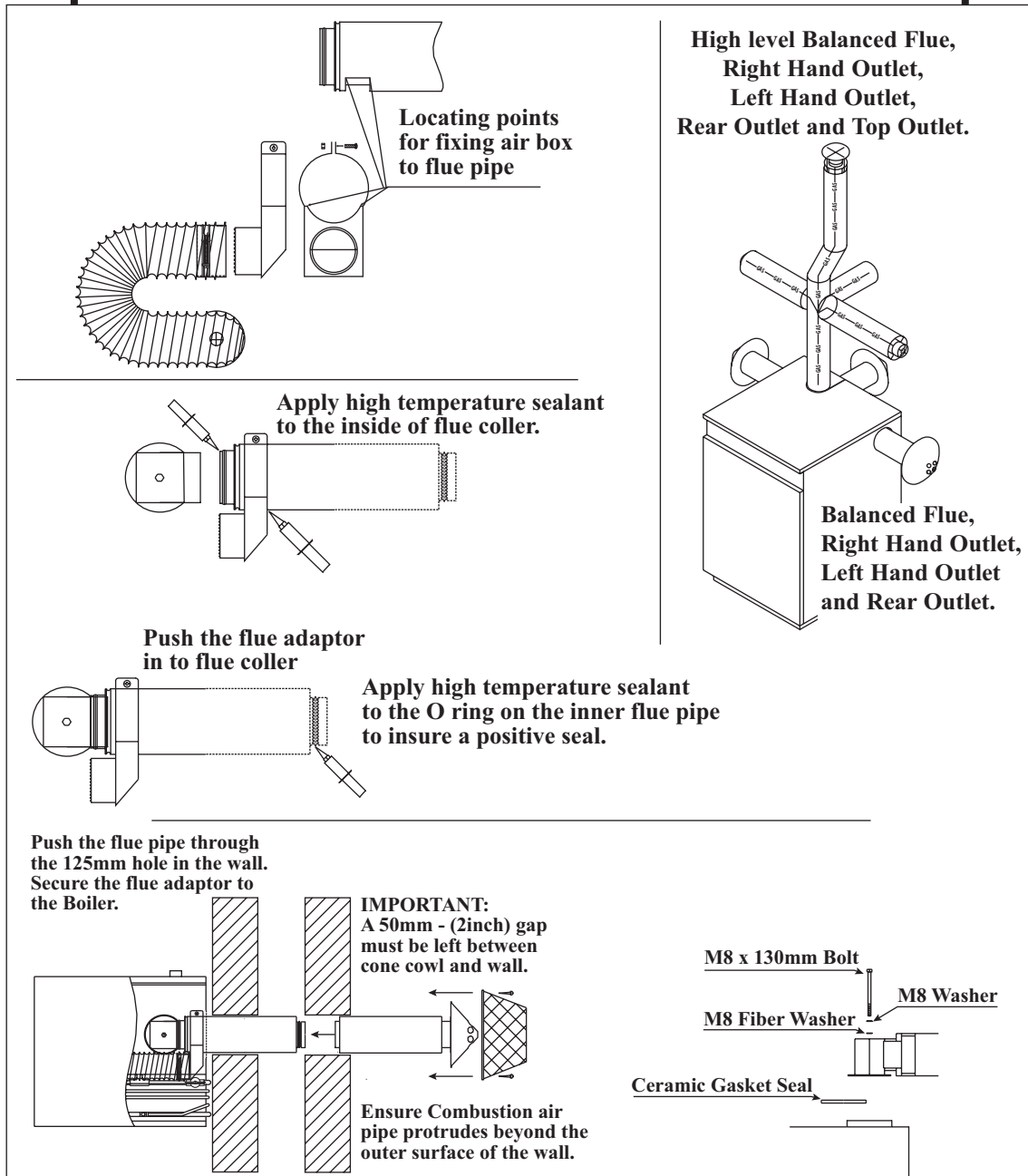

**ENSURE UNRESTRICTED AIR-SUPPLY TO BOILER ROOM.** No further adjustments are required for adequate combustion-air supply. Check burner operation when installation is completed, use burner **Combustion Analyser** to ensure correct performance.

Consult separate burner manual supplied with boiler.

# FIREBIRD

**Assembly for concentric flue when going side outlet on White cased boiler**

Secure the flue adaptor to the Boiler, ref dwg 4 and the air box to the flue pipe ref. dwg 3.

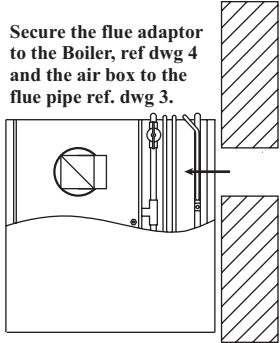

**IMPORTANT:**  
A 50mm - (2inch) gap must be left between cone cowl and wall.  
Ensure Combustion air pipe protrudes beyond the outer surface of the wall.

**Flue Extension For Right Hand Outlet Combi.**

Push the flue pipe through the 125mm hole in the wall.

Flue Extension

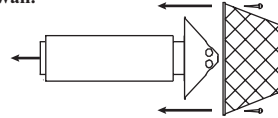

Apply high temperature sealant to the O ring on the inner flue pipe to ensure a positive seal.

**6-C Concentric Flue System**

**5" (125mm) O.D. Concentric flue Firebird S 70,000 - 90,000 and 120,000 btu's Boilers.**

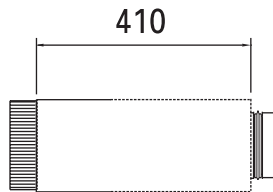

Flue Extension

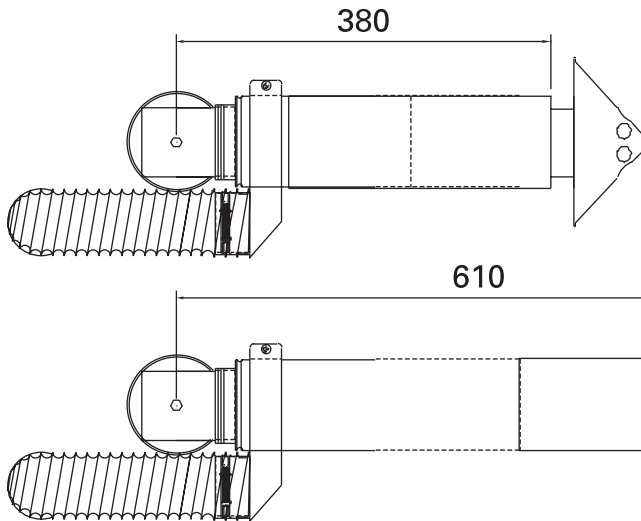

**IMPORTANT:**  
A 50mm - (2 inch) gap must be left between cone cowl and wall.

**INSTALLATION INSTRUCTIONS  
SUPPLIED WITH FLUE KITS**



**Note:** Commissioning must be carried out by a OFTEC qualified service engineer. (U.K. Only)

**It should be noted that it is the responsibility of the installer to ensure that the boiler is properly commissioned. Failure to do so may invalidate the boiler guarantee and any extended warranty.**

### **7-A Procedures**

#### **1. Oil Tank**

The installation of the oil tank and supply line should comply with all the instructions shown earlier in this manual. Consult OFTEC Manual - Book No. 3, Section 2.

If a single supply line is used ensure that the bottom of the tank is above the burner. A two pipe system should be used where the level of the oil in the tank may fall below the level of the oil burner pump.

**Check and ensure correct grade fuel oil has been supplied.**

#### **2. The Burner**

A Tigerloop single pipe system may also be used in low-level tank installations. See page 21 Section 5. Please flush out oil pipe by drawing off some oil **before** connecting fuel pipe to burner - otherwise there is a danger of grit and dirt being forced into the burner pump, resulting in pump blockage, damage and 'lock-out'

#### **3. The Boiler**

**A.** Switch off the power supply, ensure that the boiler and system is full of water, all valves are open and that installation conforms with all Standards, Regulations and Instructions.

**B. Check that boiler baffles are correctly positioned.**

**C.** Check the oil supply by disconnecting the oil supply hose at the burner and running off a quantity to ensure it is free from air. then bleed air from burner pump. Refer to section 2, page 7, sketch C, Item-E.

**D.** If fitted, check that the time switch is 'ON' and that both room and boiler thermostats are calling for heat.

**E.** Reconnect electrical supply and the boiler should start. If the burner lock-out activates, this suggests air in the pump. Wait a minute or so and try again. If lock-out occurs again, air must be bled from the pump pressure gauge connection point once more.

**F.** View the burner flame through the sight glass - it should be bright cream/yellow without any sign of smoke.

**G.** Run the boiler for about fifteen minutes then take a CO<sub>2</sub> reading and adjust as necessary.

### **7-B Handing Over**

**A thorough check of the system should be made, then the householder should receive a clear and concise demonstration of the boiler operation and any system controls.**

**This manual and burner manufacturers manual plus any other instructions should be handed over to the user, the guarantee card should be completed and posted, and the user advised about the importance of annual servicing.**

**Commissioning Record - Page 54 - should be completed and a copy kept in engineers file.**

Note: Servicing must be carried out by a OFTEC qualified engineer. (U.K. Only)

### 8-A Recommended Service Intervals

28 second oil	Once annually
35 second oil	Once annually

Ensure that 35 secs fuel oil is only used where allowed by regulations. Burner should then be re-set for this fuel. Before carrying out a service it is recommended that the following

is checked:

- A). Smoke
- B). CO<sub>2</sub>
- C). The flue gas temperature
- D). Oil pressure

#### E). Ensure flue is unrestricted & operating properly

At the same time check for oil and combustion leaks. Advance to service **ONLY** after ensuring that both electric and oil supply to boiler is disconnected.

### 8-B The Oil Tank

Draw off any accumulated water and sludge from the tank by opening the drain cock. Turn off the oil supply and remove the filter bowl, then wash the element clean with kerosene.

### 8-C The Boiler

Remove combustion access door for access to baffles and to clean heat exchanger.

Check insulation sealing and its silver foil lining in combustion access door - replacing when necessary. When refitting this door be careful not to damage the foil and insulation by over tightening.

### 8-D The Burner

Check performance of oil-nozzle and replace as necessary.

#### Ensure correct specification replacement nozzle is used.

Check all oil filters and replace as necessary.

Remove burner and clean blast tube and ensure that airways are clear.

Ensure electrodes are clean, dry, not broken and are set as per burner specifications.

Clean fan and photocell.

**Once again check flexible oil lines and connections for damage or leaks, replace as necessary.**

#### Combustion Check

Carry out combustion analysis and ensure that boiler is performing to specification outlined in manual. Flue conditions may cause deviation from these figures.

**Always keep careful record of flue gas analysis results including any verbal and written advice to customer (householder).**

**Always check carefully for restricted or blocked flue. If possible record CO levels and advise customer of need to keep boiler room well ventilated.**



A large, dark silhouette of an eagle with its wings spread wide, positioned on the left side of the page. The eagle's head is turned towards the right, and its talons are visible at the bottom. The background is a light gray gradient.

# *Combi Oil Boiler*

## *PART 2*

### *Sealed System & Domestic Hot Water*

# DOMESTIC HEATING AND HOT WATER

## SEALED HEATING CIRCUIT

The system must comply with BS 7074 Part 1 and BS 5449 Part 1 with a maximum water temperature of 80°C.

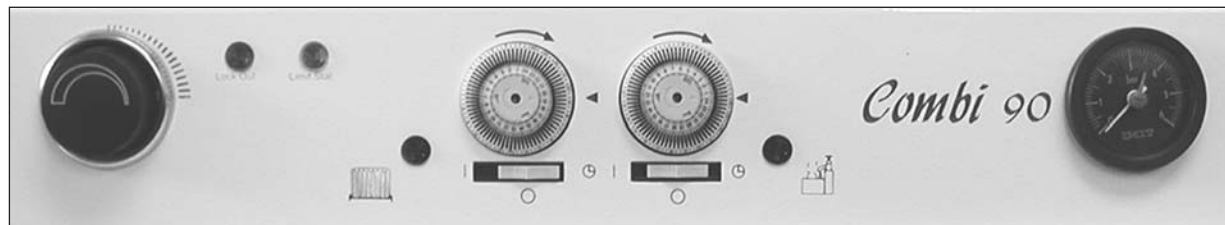

\* A manual reset overheated limit thermostat is located at the rear of the electrical control panel (see page 11). If a boiler overheat condition arises the burner will stop and remain inoperative until this thermostat reset button is depressed.

\* A pressure relief valve to BS 6759 operating at 3 bar (45 lb/in<sup>2</sup>) is fitted. A discharge pipe of 15 mm diameter is also fitted to the discharge connection on the pressure relief valve. During installation an extension pipe should be fitted to this, leading to outside the building. The pipe should be as short as possible and may need a tundish fitted in a protected position within the building.

Alternatively, if acceptable, it may discharge within building. In this case the discharge pipe **outlet end**, should terminate within 100 mm above inside floor level, and be in a visible and accessible position. No tundish is necessary in this position and

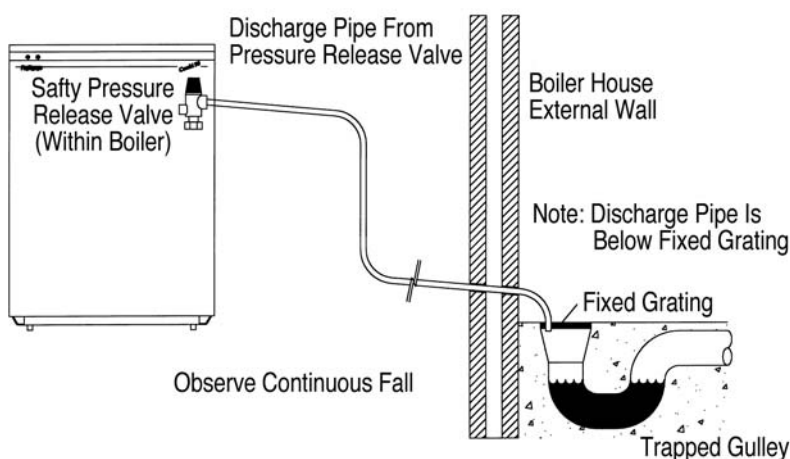

householder should be advised that this discharge end should always remain open. In every case it should be directed downwards away from any electrical components or where it could cause a hazard to the user/occupier. See diagram above.

**Note:- Water must not discharge above an entrance, window or where public have access. The installer must be aware that the discharge may be boiling water.**

\* A drain cock must be fitted at the lowest points in the system to enable draining as necessary. A drain cock is already fitted at the bottom of the boiler heat store to enable draining of boiler and tank unit only. All pipes connected to boiler should have shut off valves fitted to facilitate this.

\* A Pressure gauge, having range 0 to 6 bar is fitted to boiler control panel. This indicates water pressure in boiler and system at time of reading. **Pressure when cold should be 1 bar minimum to 1.5 bar maximum.** This is known as Initial System Design Pressure (P<sub>i</sub>).

A manually adjustable red pointer is also fitted on the protective glass of pressure gauge. This has a screwdriver slot. When system is cold and filled to Initial Fill Pressure  $P_i$  this pointer should be rotated to **read exactly as black pointer** on dial. This should not be subsequently altered. If system pressure, as indicated on black pointer on dial, falls **below** that indicated by red pointer when system and boiler are cold this means that Initial System Fill Pressure has dropped. Refill system until indicated pressure rises to the same as red pointer indicates - in this case 0.7 bar, as shown on accompanying pressure gauge sketch. Sketch also shows black pointer indicating maximum final system design pressure ( $P_f$ ).

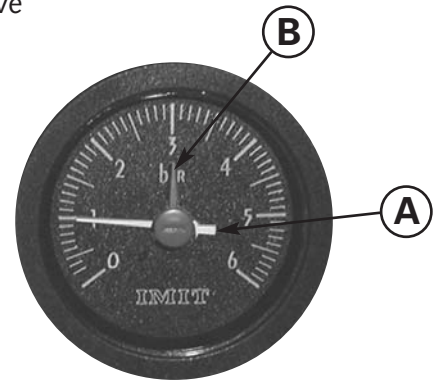

**N.B. Initial System Design Pressure (measured in bar) equals static head of system (measured in bar) plus 0.3.**

\* A 12 or 14 litre expansion vessel is fitted to boiler, precharged with air or nitrogen to **1 bar** which allows a system static head of 5 metres. If the static head is greater than this then the air charge in the vessel must be increased to balance the higher static head. **The air charge should not exceed a pressure of 1.5 bar.**

The Firebird Combi Boiler's **with built in Expansion Vessel's** having an initial air charge pressure of 1 bar. If total water content of system is greater than the capabilities of the vessel supplied **then an additional vessel** will be required to be fitted to the **return** pipe as close as is practicable to the boiler. There should be no valves or restrictions between vessel and boiler. **See page 34 for vessel sizes.**

If static head is altered then it is also necessary to alter air charge pressure to equal static head (+ 0.3 Bar). This is necessary in order to keep system water from entering expansion vessel until system is being heated and thus allow its maximum acceptance volume (V) to be used **only to accommodate the expansion of system water during boiler operation.**

Remember that air charge pressure **must** be **equal** in both vessels (attached to the same system). In the above example this is 1 bar. **Air charge pressure** is the air pressure in expansion vessel **before** system is filled. It is measured with a tyre gauge attached to Schrader valve on the vessel.

N.B. N.B. With heating system up to full working temperature, if the final system design pressure ( $P_f$ ) reads more than 2.6 bar, as indicated on control panel pressure gauge, then it is likely that:

- (a) **Total** system water content is greater than that calculated and if additional expansion vessel has been fitted it should be replaced with a larger unit  
**OR** if integral boiler expansion vessel only is used then an additional expansion vessel is required.
- (b) Static head may be higher than calculated. In this case it is necessary to re-measure static head and revise expansion vessel air charge pressure.
- (c) Expansion vessel incorrect size or air charge pressure incorrect.

Refer to BS 7074 Part 1 and BS 5449 for further information.

## DOMESTIC HEATING AND HOT WATER

### EXPANSION VESSEL AND SYSTEM REQUIREMENTS

Safety Valve Setting	3 bar		
Initial System Pressure	0.5 bar	1.0 bar	1.5 bar
Total Water Content of System	TOTAL VESSEL VOLUME **		
Litres	Litres	Litres	Litres
25	2.1	2.7	3.9
50	4.2	5.4	7.8
75	6.3	8.2	11.7
100	8.3	10.9	15.6
125	10.4	13.6	19.5
150	12.5	->[16.3]<-	23.4
175	14.7	19.1	27.2
200	16.7	21.8	31.2
225	18.7	24.5	35.1
250	20.8	27.2	39.0

**FOR FURTHER INFORMATION CONSULT APPROPRIATE TRAINING MANUALS AND BS 7074 PART 1, BS 5449, ETC**

\* \* When calculating size of any additional expansion vessel required, remember to deduct the boiler expansion vessel volume of 10 litres from the calculated total system vessel volume required, as given in above table.

**EXAMPLE: using above table**

If .....Total water content of system - 150 litres  
 And .....Initial system pressure required is - 1.0 bar  
 Then .....Vessel volume required [from above table] - 16.3 litres  
 But .....Vessel supplied with boiler - 10.0 litres  
 Therefore ....Additional vessel required - 6.3 litres (minimum)  
 (For this system of 150 litres - total water volume)

..Nearest available stock size for additional vessel required, at 1 bar initial system pressure (taken from above table) is 8 Litres.

It is emphasised that the installer should be fully acquainted with sealed system installation and operation, calculation of total system water volume, determining of initial system pressure required and calculation of any additional expansion vessel volume required.

NB .. Ensure that all expansion vessels in the same system are set at EQUAL air charge pressures.

## DOMESTIC HEATING AND HOT WATER

### Domestic Hot Water Circuits

The final 600 mm mains water supply should be of copper tube to BS 2871 Part 1. Ensure that any capillary fittings used are of lead free solder variety. For user comfort the mains pressure at taps should be between 1 and 5 bar. If it exceeds this it is advisable to fit a pressure reducing valve adjusted to reduce pressure to an acceptable level within above range. To ensure user comfort and satisfaction it may be advisable to discuss foregoing with householder. Where long hot water supply-pipe runs are used these should be insulated to prevent rapid cooling of residual hot water after draw off is completed.

If the boiler is fitted in a hard water area check that hardness does not exceed 200 p.p.m. by testing with a standard test strip. Immerse test strip in flowing tap water for one second. Shake off excess water. Check strip after approximately fifteen seconds. If three or more zones have changed colour the water hardness is over 200 p.p.m. (**Read instructions on test strip package**). Fitting of an in line scale inhibitor is then necessary.

**Failure to check water hardness and fit appropriate water softening equipment will result in scale build up and consequent reduction in water heating performance. Check with local Water Authority if in doubt.**

Hot and Cold taps, mixing valves and fittings must be suitable for operating at mains pressure up to 10 bar Bidets with the supply of hot and cold mains water are permitted if they are of the over-rim flushing type and have shrouded outlets which enable them to have temporary hand held spray attached. Showers of loose headed or flexible type must be fixed so that the head cannot fall closer than 25 mm above the top edge of the bath to prevent it immersing into the bath water. Alternatively the shower should have an anti-syphoning device incorporated at the point of the flexible connections.

### Water Flow Regulation

The flow rate of water from individual taps may be affected by any of the following:-

1. Number of taps in use at one time
2. Cold mains pressure
3. Diameter and length of pipework in the domestic water circuits within the dwelling.
4. Excessive flow from 3/4" bath taps in a house system converted to mains water supply.

It is recommended:-

- A. To ensure that the mains water connection to the appliance is the first connection from the mains on entering the dwelling.
- B. Where flow starvation is encountered that flow restrictors or balancing valves are fitted at supply outlets.

\* The boiler has circulating pumps fitted therefore no other is normally required. They are factory set at maximum output. This setting should not be altered on the domestic hot water pump as production of domestic hot water may be adversely affected.

# SYSTEM FILLING, TESTING AND MAKE-UP

## Introduction

Mains cold water is supplied through the boiler pipework to two separate circuits operating at different pressures.

## Circuit One

This is the Radiator Heating System including boiler and primary tank which is filled from mains supply via flex filling loop (Page 45) within boiler to a pressure determined from system static head, expansion vessel size and system water volume. This flexible filling loop should be disconnected when boiler and system are filled and checked, See diagrams below.

## Circuit Two

This is the domestic **cold** water supply through the boiler plate heat exchanger via domestic hot water pipework direct to hot taps. This works at full mains pressure or if this is excessive at a reduced pressure controlled by a mains pressure reducing valve to a pressure acceptable to householder and satisfactory for the correct operation of Combi Boiler System. This mains pressure reducing valve is **not supplied with boiler**, but will be available from a local supply merchant.

System filling should take place **slowly** and can be done by either of the following methods:-

## Manual Filling

The Firebird Combi 90 comes with this system built into the appliance. It consists of a flexible hose connection with a butterfly shut off valve at each end and a double check valve assembly at boiler end. To conform to requirements of BS 7074 Part I and local water Authority Bye Laws, the flexible hose should be disconnected at one end when filling has been completed and checked. Two end caps are supplied and should be fitted to disconnected ends as a safety precaution against inadvertent opening of ball valves.

Pressure gauge on Control Panel should be checked occasionally when system is cold. Refill to initial fill pressure if necessary. Should this be a frequent occurrence, complete system should be checked for leaks.

### Method A

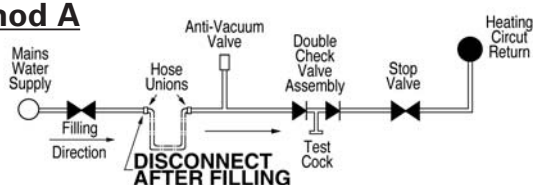

## Automatic Filling

Automatic System filling may be made with a feed and make-up cistern connected through a double check valve and stop valve assembly to the return side of the heating system as close to the boiler as is practicable. This cistern **should be located above** the heating systems highest point to give a **minimum** static head of 300 mm between it (highest point) and cistern. The manual filling system fitted to boiler should then be disconnected and connection points blanked off.

This system has the advantage of automatic water make-up in the event of system pressure loss due to air elimination and minor leaks. In any case control panel pressure gauge should be occasionally checked.

**Remember also to check air fill pressure of Expansion Vessel when system is cold using standard tyre gauge connected to Schrader air valve on vessel.**

### Method B

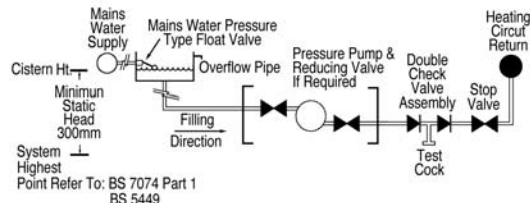

**NOTE:** There shall be no direct connection to the mains, even with the use of a non-return valve without the permission of Local Water Authority.

\* It is recommended that an inhibitor be added at the time of final fill to protect the System from corrosion. Ensure that this is carried out in accordance with inhibitor manufacturers instructions. Installer should ensure that inhibitor used is suitable and that it will have no adverse effect on Expansion Vessels diaphragms or any other part or component of the system.

## SYSTEM FILLING, TESTING AND COMMISSIONING

\* Before proceeding to filling, ensure that electricity supply is switched off at mains to avoid any possibility of time switch operating and passing power to appliance prior to filling.

### Filling and Testing

Check that **all** connections, especially compression joints, are fully tightened. Re-check and ensure that pressure vessel air charge is correct, then fill system with water via filling system used. **Turn off water supply before system pressure reaches safety valve operation point of 3 bar.** (Say 2 to 2.5 bar). Vent system via all manual air vents **including circulating pumps**, boiler, radiators, system high points. etc. Check that dust caps are loosened on auto air vents, keep constant check on system pressure gauge (fitted to control panel). If pressure has dropped readmit water to above pressure. Ensure **all** appropriate boiler and system valves **are open**.

With water supply turned off, **thoroughly** flush out boiler and system to remove **all** foreign matter before allowing boiler and pumps to operate. If in doubt drain system and repeat above procedure. At this stage flushing-out water should be clean and clear of all foreign matter.

Refill the system and again vent at all points as described above. Examine the complete system for water leaks having pressurised it to 1.5 - 2.5 bar. Correct any leaks, then check operation of safety valve by admitting further water until this valve operates. This should occur when system pressure rises to between 2.7 and 3.3 bar. When satisfied with valve operation, and with mains water still turned off, draw off sufficient water until initial system design fill pressure ( $P_f$ ). (cold fill) is established (0.5 - 1.5 bar - as calculated for system). The red pointer B on pressure gauge should then be set at this initial system design pressure ( $P_f$ ), i.e. system static head +0.3

Remember that initial cold fill pressure can only be checked when system water has properly cooled down. Check that **final operating pressure** ( $P_f$ ) is under 2.5 bar with **all** radiators turned on and up to highest working temperature. Should system operating pressure exceed this, check:

1. That initial cold fill pressure is correct and, if additional expansion vessel is fitted, that pressure is equal in each vessel,
2. That expansion vessels are sized correctly.

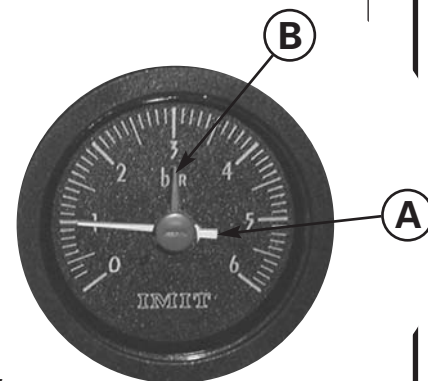

Special attention should be given to existing heating systems where Firebird Combi boiler has replaced an existing unit. Extra effort should be made to ensure that all original pipe work and radiators are repeatedly flushed. If possible use a proprietary cleansing agent suitable for system as loosened scale and foreign matter can seriously reduce domestic hot water performance and pump efficiency.

Use corrosion inhibitor of suitable type.

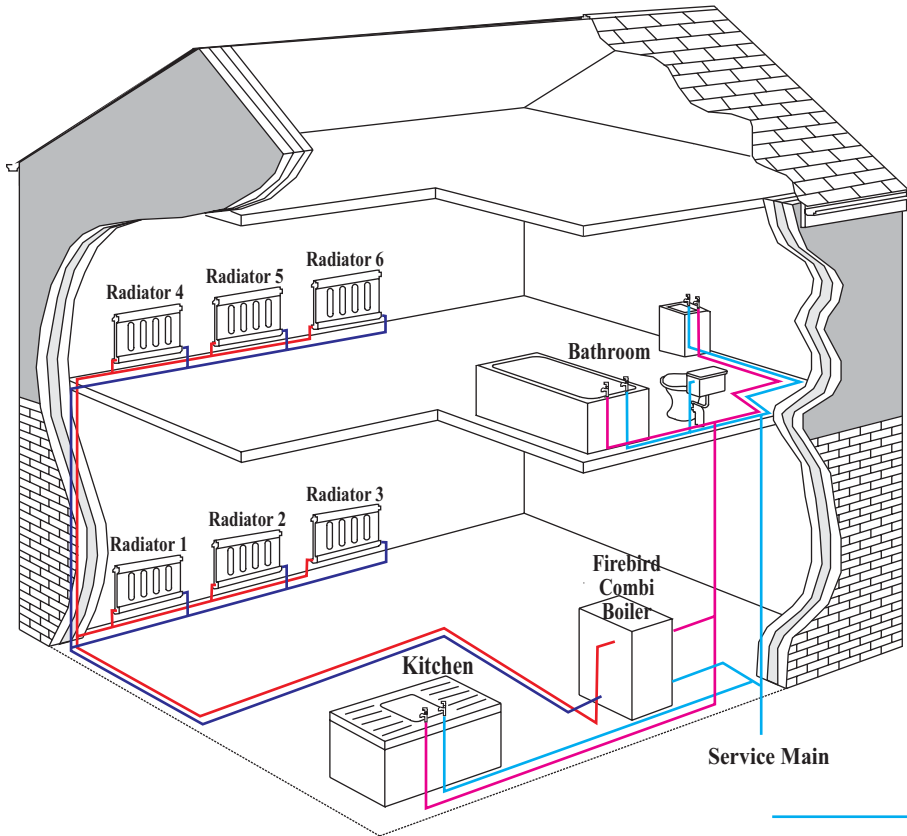

**Firebird Combi System**

- Domestic Cold Feed
- Domestic Hot
- Central Heating Cold
- Central Heating Hot

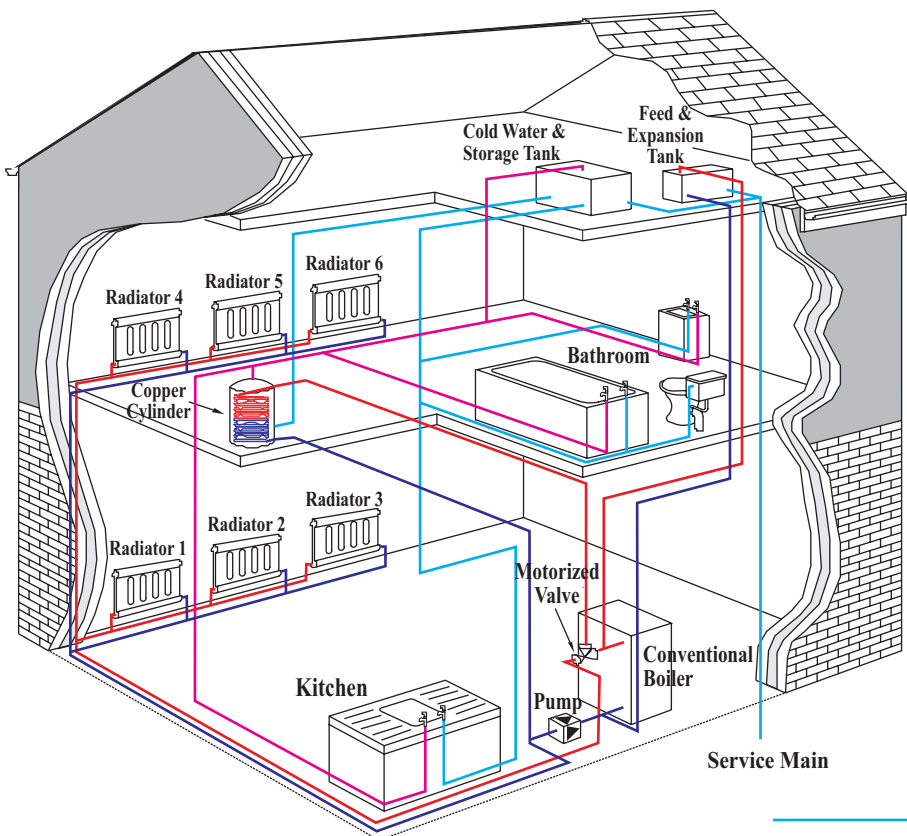

**Typical Conventional Boiler System**

- Domestic Cold Feed
- Domestic Hot
- Central Heating Cold
- Central Heating Hot

A large, dark silhouette of an eagle with its wings spread wide, positioned on the left side of the page. The eagle's head is turned towards the right, and its talons are visible. The background is a light gray gradient.

# *Combi* *Oil Boiler*

## *PART 3*

### *Spare Parts*



**Fault Finding Logic For Control Box Type 5352 SE/LD RDB Series Oil Burners**

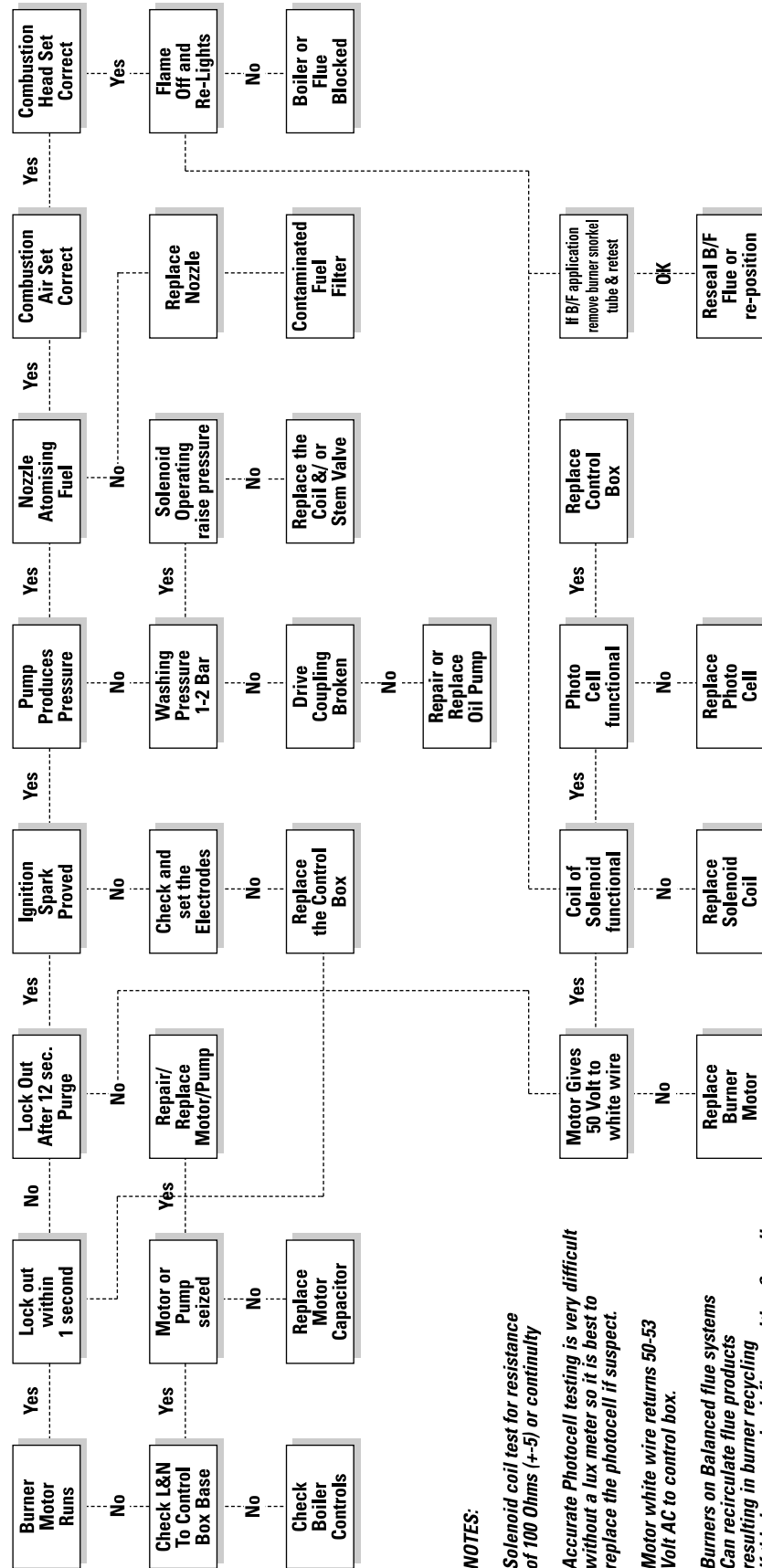

**NOTES:**

Solenoid coil test for resistance of 100 Ohms (+-5) or continuity

Accurate PhotoCell testing is very difficult without a lux meter so it is best to replace the photoCell if suspect.

Motor white wire returns 50-53 Volt AC to control box.

Burners on Balanced flue systems Can recirculate flue products resulting in burner recycling if this happens check flue position & sealing.

# 10 SPARE PARTS-BURNER

## 10-A Burner Parts Illustration

Riello RDB Burner

RDB1 Firebird 70K

C.O.D. 3513105

TYPE 501 T1K

RDB1 Firebird 90K

C.O.D. 3513205

TYPE 501 T1K

RDB2 Firebird 120K

C.O.D. 3513605

TYPE 501 T3K

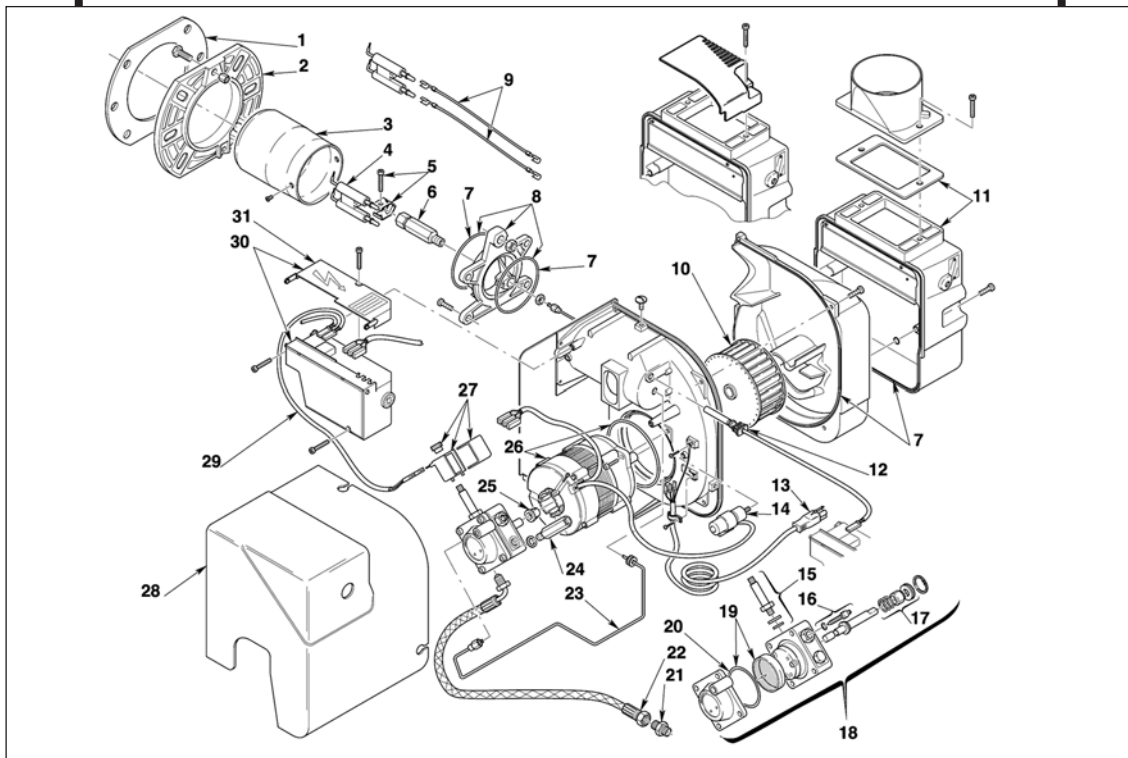

### Riello RDB Burner Parts

No.	3513105	3513205	3513605	Code Spare Parts	Description
1	•	•	•	3008512	Gasket
2	•	•	•	3006384	Flange
3	•	•	•	3002507	Cup-Shaped Head
3	•	•	•	3002447	Cup-Shaped Head
4	•	•	•	3007513	Electrode Assembly
5	•	•	•	3006552	Electrode Bracket
6	•	•	•	3008642	Nozzle Holder
7	•	•	•	3008878	Kit Seals
8	•	•	•	3008643	Collar
9	•	•	•	3008794	High Voltage Lead
10	•	•	•	3005708	Fan
10	•	•	•	3008645	Fan
11	•	•	•	3008647	Air Damper Assembly
11	•	•	•	3008839	Air Damper Assembly
12	•	•	•	3008646	P.E. Cell
13	•	•	•	3002657	4 Pole Socket
14	•	•	•	3007479	Capacitor 4uf
15	•	•	•	3007582	Needle Valve
16	•	•	•	3008651	Regulator
17	•	•	•	3000439	Pump Seal
18	•	•	•	3008654	Pump
19	•	•	•	3008653	Filter - O - Ring
20	•	•	•	3007162	O - Ring
21	•	•	•	3009068	Connector
22	•	•	•	3007621	Flexible Oil Line
23	•	•	•	3008644	Tube
24	•	•	•	3008876	Pressure Gauge
25	•	•	•	3000443	Joint
26	•	•	•	3008650	Motor
27	•	•	•	3008648	Coil
28	•	•	•	3008879	Cover
29	•	•	•	3008851	Lead Coil
30	•	•	•	3008652	Control Box 535RSE/LD
31	•	•	•	3008649	Protection
32	•	•	•	3007418	4 Pin Plug

# FIREBIRD

# 10 SPARE PARTS-BOILER

## 10-B Combi Plumbing Parts Illustration

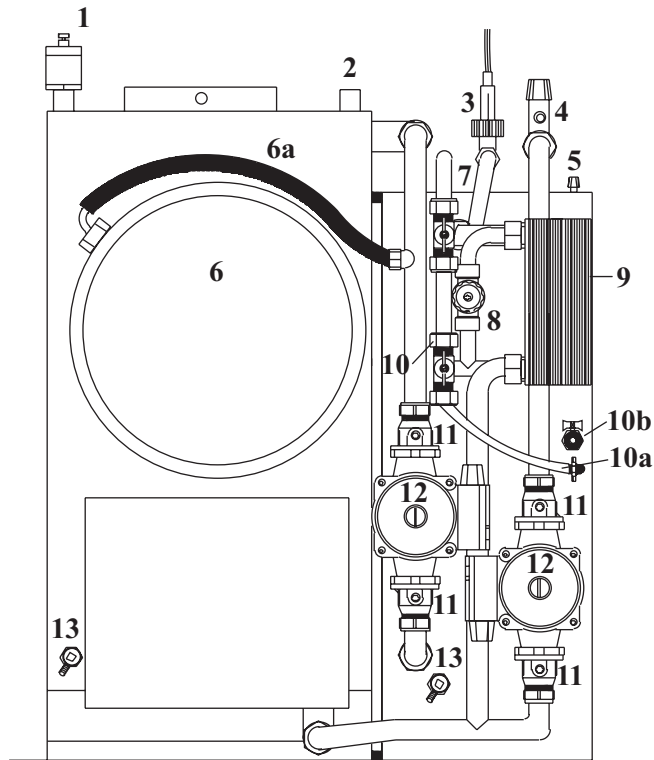

Combi 90 Boiler (Elevation)

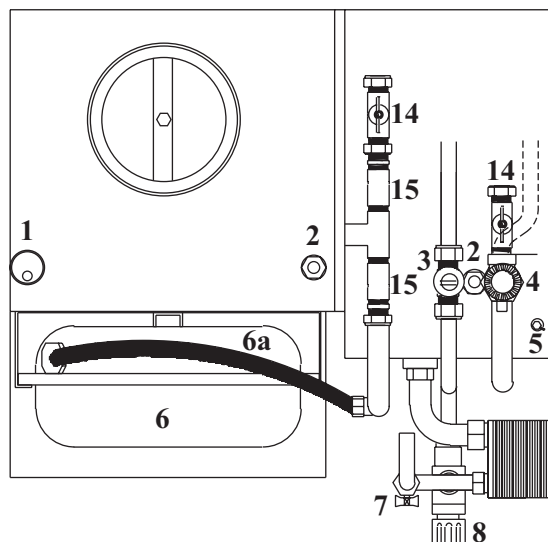

Combi 90 Boiler (Plan)

# 10 SPARE PARTS-BOILER

## 10-C Combi Plumbing Parts Description

ITEM No.	COMPONENT	PART No.	Qty per boiler
1	Auto air vent	FC 03010	1
2	Stat Pocket	FC 03020	2
	Filler Spring	FC 03020a	1
	Locking Spring	FC 03020b	1
3	SIKA Flow Switch	FC 03030	1
4	Safety Valve	FC 03040	1
5	Manual air vent	FC 03050	1
6	10 Ltr. Pressure Vessel 50/70	FC 0306070	1
	12 Ltr. Pressure Vessel 70/90	FC 0306090	1
	14 Ltr. Pressure Vessel 90/120	FC 03060120	1
6a	Cf 3/4" x F12" Hose	FC 03060	1
7	15mm double check mains isolating valve	FC 03070	1
8	Thermostatic Mixing valve	FC 03080	1
9	25 Plate heat exchanger	FC 0309090	1
	31 Plate heat exchanger	FC 03090120	1
10	Filling loop 15mm isolating valve	FC 03100	1
10a	Filling loop hose		
10b	Filling loop 15mm check valve		
11	Pump Valve	FC 03101	4
12	Circulating Pump	FC 03102	2
13	1/2" drain cock	FC 03103	2
14	22mm Ball valve	FC 03104	2
15	3/4 M/Fm Check Valve	FC 03105	2

# 10 SPARE PARTS-BOILER

## 10-D Combi Parts Illustration

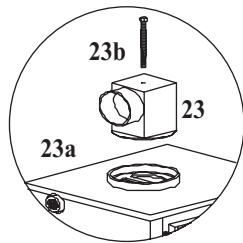

For Low Level  
Balanced Flue Only

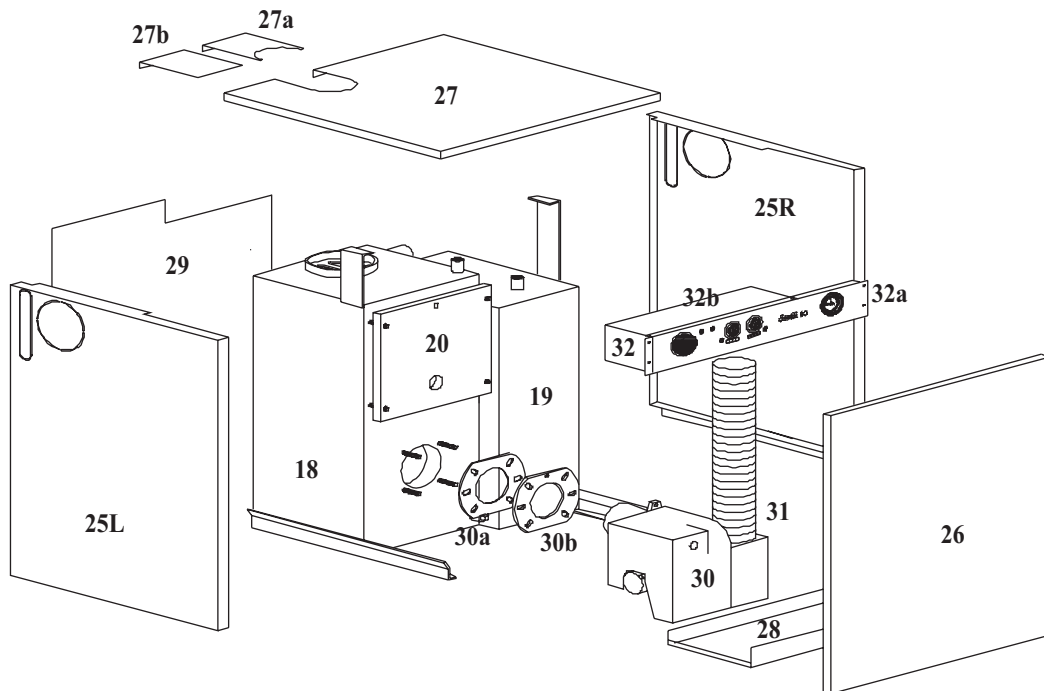
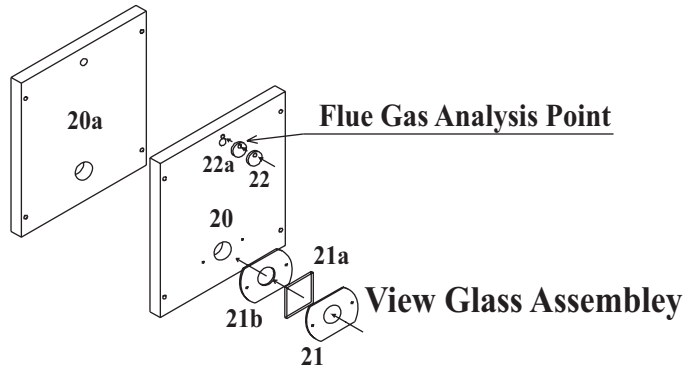

Baffle Setup For  
Combi 50/70

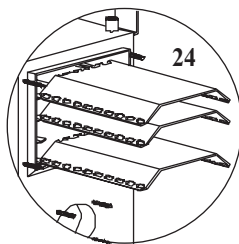

Baffle Setup For  
Combi 70/90

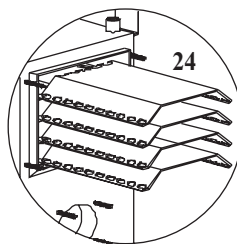

Baffle Setup For  
Combi 90/120

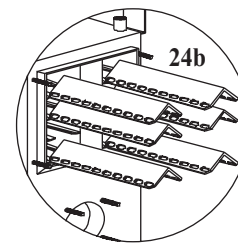

# 10 SPARE PARTS-BOILER

## 10-E Combi Parts Description

ITEM No.	COMPONENT	PART No.	Qty per boiler
18	Combi Boiler 50/70 - 70/90	FC 0310690	1
	Combi Boiler 90/120	FC 0310612	1
19	Combi Tank 50/70 - 70/90	FC 0310790	1
	Combi Tank 90/120	FC 0310712	1
20	Combustion chamber door 50/70 - 70/90	FC 0310890	1
	Combustion chamber door 90/120	FC 0310812	1
20a	Door Gasket 50/70 - 70/90	FC 03109	1
	Door Gasket 90/120	FC 0310912	1
21	Viewing glass bracket	FC 03110	1
21a	Viewing glass	FC 03111	1
21b	Viewing glass gasket	P70-L-45	1
22	Flue gas analysis point blank	FC 03113	1
22a	Flue gas analysis point gasket	FC 03114	1
23	Flue adapter	FC 03115	1
23a	Flue adapter gasket	FC 03116	1
23b	M8 x 140mm Bolt	FC 03117	1
24	50/70 - 70/90 Baffle	P90-L-09	3-4
24b	90/120 Baffle	P120-L-09	8
25L	Left side panel	FC 03118L	1
25R	Right side panel	FC 03119R	1
26	Front panel 50/70 - 70/90	FC 03120	1
	Front panel 90/120	FC 0312012	1
27	Top panel 50/70 - 70/90	FC 03121	1
	Top panel 90/120	FC 0312112	1
27a	Top panel blanking plate	FC 03122	1
27b	Top panel flue finishing plate	FC 03123	1
28	Drip tray	FC 03124	1
29	Foil Lagging	FC 03125	1
30	RDB Burner	See page 41	1
30a	Burner flange		1
30b	Burner flange gasket		1
31	Flexible air hose	FC 03126	1
32	Control panel back	FC 03129	1
32a	Control panel front 50/70 - 70/90	FC 03130	1
	Control panel front 90/120	FC 0313012	1
32b	Control panel top	FC 03131	1

# 10 SPARE PARTS-BOILER

## 10-F Combi Control Panel Illustration

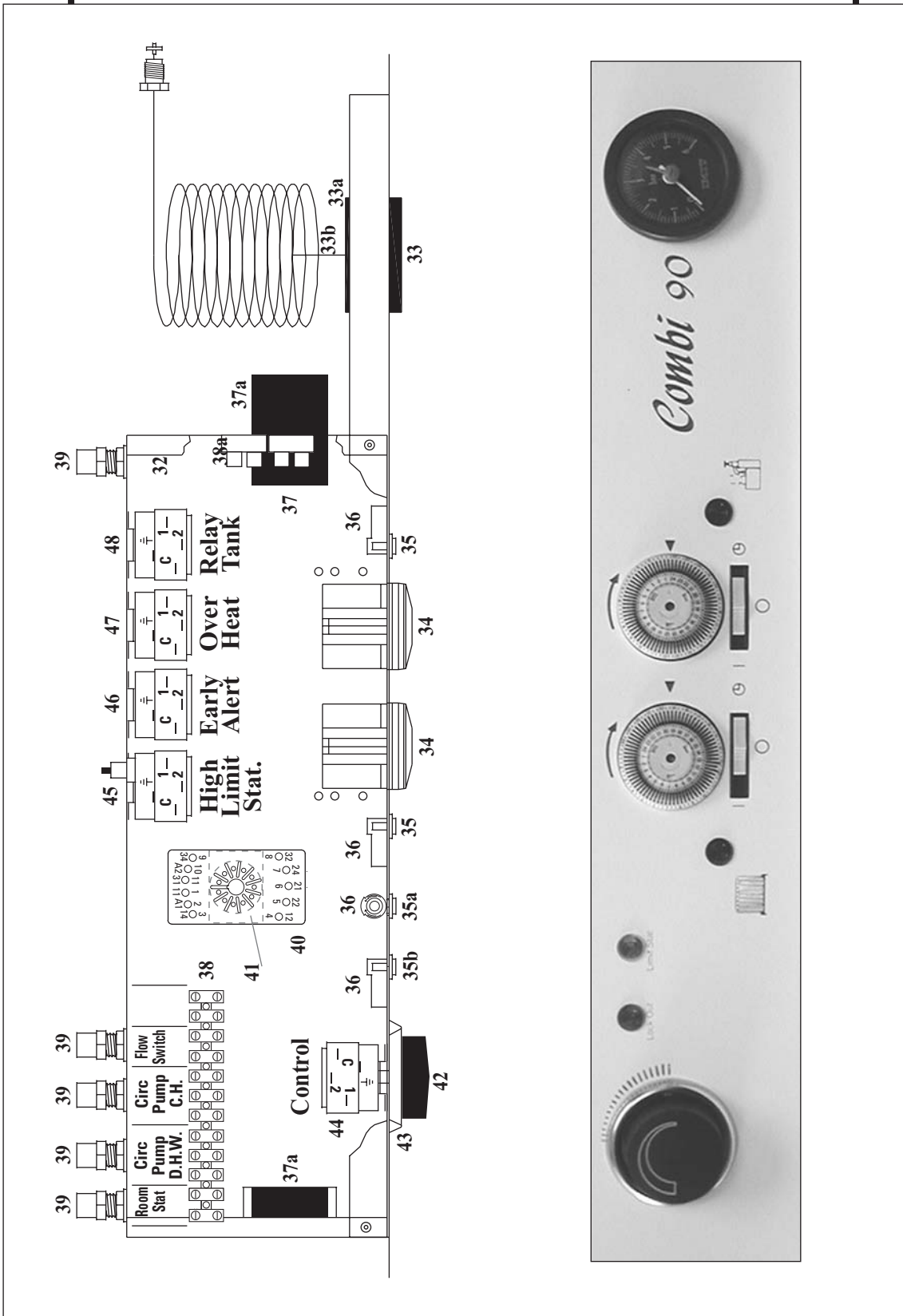

# 10 SPARE PARTS-BOILER

## 10-G Combi Control Panel Description

ITEM No.	COMPONENT	PART No.	Qty per boiler
32	Control panel back	FC 03129	1
32a	Control panel front	FC 03130	1
32b	Control panel top	FC 03131	1
	Timer bracket	FC 03132	1
	Timer blank	FC 03133	1
33	Pressure Gauge	FC 03134	1
33a	Bracket for pressure gauge	FC 03135	1
33b	Nut for pressure gauge	FC 03136	1
34	Timer	FC 03137	2
35	Green neon light indicator	FC 03138	2
35a	Orange neon light indicator	FC 03139	1
35b	Red neon light indicator	FC 03140	1
36	Green Light Bulb	FC 03141 G	2
36a	Orange Light Bulb	FC 03141 O	1
36b	Red Light Bulb	FC 03141 R	1
37	4 Pin Socket	FC 03142	2
37a	4 Pin Plug	FC 03143	2
38	Wiring Strip connector	FC 03144	1
38a	Timer two piece wiring strip connector	FC 03145	1
39	Cable Gland	FC 03156	5
40	Relay base	FC 03147	1
41	Relay	FC 03148	1
42	Control stat eyebrow knob	FC 03149	1
43	Control stat chrome bezel.	FC 03150	1
44	Control stat	FC 03151	1
45	Limit Stat	FC 03152	1
46	Early alert stat	FC 03153	1
47	Over run stat	FC 03154	1
48	Relay tank stat	FC 03155	1

# Commissioning Record

**This record should be carefully completed, remain in this manual and be left with householder. A copy should be kept on file by engineer**

Date: \_\_\_\_\_

Commissioning Engineer:-

Name: \_\_\_\_\_ Tel. No: \_\_\_\_\_

Address: \_\_\_\_\_  
\_\_\_\_\_

Boiler:-

Type \_\_\_\_\_ Output: \_\_\_\_\_

Fuel Used: Kerosene (28 sec) or Gas oil (35 sec)

Burner:-

Nozzle size: \_\_\_\_\_ Nozzle Type: \_\_\_\_\_

Pump Pressure: \_\_\_\_\_ Air Setting: \_\_\_\_\_

Flue Gas % CO<sub>2</sub>: \_\_\_\_\_ Net Flue gas temp: \_\_\_\_\_

Smoke No: \_\_\_\_\_

Sealed system design pressure (cold): \_\_\_\_\_

Sealed system final operating pressure (P<sub>f</sub>) : \_\_\_\_\_

Commissioning Engineer Signature: \_\_\_\_\_

Notes & Comments

# Service Report

**NB** All Information recorded hereunder should also be included in Engineers own filed service reports. It is recommended that the boiler be serviced, **at least once a year**, and the details recorded below. Combi Boilers may need more frequent service. Engineer should advise householder.

Date	% CO <sub>2</sub>	Net Flue gas temp	Smoke No.	Nozzle	Service Engineer/Tel. No. Signature & Comments
				Type ..... Size ..... Angle ..... Pressure .....	Signature:.....
				Type ..... Size ..... Angle ..... Pressure .....	Signature:.....
				Type ..... Size ..... Angle ..... Pressure .....	Signature:.....
				Type ..... Size ..... Angle ..... Pressure .....	Signature:.....
				Type ..... Size ..... Angle ..... Pressure .....	Signature:.....
				Type ..... Size ..... Angle ..... Pressure .....	Signature:.....
				Type ..... Size ..... Angle ..... Pressure .....	Signature:.....
				Type ..... Size ..... Angle ..... Pressure .....	Signature:.....
				Type ..... Size ..... Angle ..... Pressure .....	Signature:.....



# Service Report

**NB** All Information recorded hereunder should also be included in Engineers own filed service reports. It is recommended that the boiler be serviced, **at least once a year**, and the details recorded below. Combi Boilers may need more frequent service. Engineer should advise householder.

Date	% CO <sub>2</sub>	Net Flue gas temp	Smoke No.	Nozzle	Service Engineer/Tel. No. Signature & Comments
				Type .....	Signature:.....
				Size .....	
				Angle .....	
				Pressure .....	
				Type .....	Signature:.....
				Size .....	
				Angle .....	
				Pressure .....	
				Type .....	Signature:.....
				Size .....	
				Angle .....	
				Pressure .....	
				Type .....	Signature:.....
				Size .....	
				Angle .....	
				Pressure .....	
				Type .....	Signature:.....
				Size .....	
				Angle .....	
				Pressure .....	
				Type .....	Signature:.....
				Size .....	
				Angle .....	
				Pressure .....	



## NOTES

# FIREBIRD Guarantee

**1. Firebird hereby guarantees the following** (The Guarantees)

a. The heat exchanger will be free from defective parts or workmanship for a period of 5 years from the date of installation.

b. Burner, controls and flue kits (supplied by Firebird) will be free from defective parts or workmanship for a period of 2 years from the date of installation. With the exception of burner nozzles. Which should be replaced at the recommended service intervals.

**2. Guarantees are subject to the following conditions:**

a. All claims under the guarantees must be within the above stated time limits.

b. The boiler must be commissioned by qualified persons and as set out in the Installation Manual, using correct test equipment.

c. Maintenance should be carried out at the intervals stated in the Installation Manual.

d. Installation of the boiler must be in accordance with  
(a) Installation Manual, (b) all relevant standards and codes of practice.

e. Firebird can accept no liability in respect of any defect arising from incorrect installation, negligence, fair wear and tear, misuse, alteration or repair by unqualified persons.

f. Firebird will not accept any liability in respect of any defect occurring in the heat exchanger due to limescale build-up and or low return water temperature.

g. The guarantees extend to reasonable labour costs EXCEPT under clause 1a where any valid claim made after 3 years will not include labour costs.

h. Firebird's prior authorisation must be obtained before examination or repair of the boiler takes place.

i. Firebird will examine all claims made under the guarantees and for any claims that are deemed invalid, the costs incurred will be borne by the owner.

3. Any defective part removed under any or all of the guarantees **MUST** be returned to Firebird.

STATUTORY RIGHTS OF THE OWNER ARE NOT AFFECTED BY THIS GUARANTEE

## Firebird Boilers Guarantee Registration

### IMPORTANT

Please ensure that the appliance is commissioned and the installer or commissioning engineer fills in the commissioning check details below, which should then be promptly returned to nearest Firebird address.

**FIREBIRD UK**  
UNIT 6, WESTOVER INDUSTRIAL ESTATE,  
IVYBRIDGE, DEVON, ENGLAND. PL21 9ES  
TEL: 01 752 691177  
FAX: 01 752 691131

**FIREBIRD BOILERS**  
BALLYMAKEERA,  
CO. CORK, IRELAND.  
TEL: 026 45253  
FAX: 026 45309

**FIREBIRD PRODUCTS**  
SHEAN, FORKHILL,  
NEWRY, N. IRELAND. BT35 9SY  
TEL: 028 30888330  
FAX: 028 30889096

TEAR OFF HERE & RETURN TO THE APPROPRIATE ADDRESS

### HOUSEHOLDER (In block capitals)

NAME .....

ADDRESS .....

.....

POSTCODE ..... TEL .....

### INSTALLER (In block capitals)

NAME .....

ADDRESS .....

.....

POSTCODE ..... TEL .....

BOILER MODEL ..... OUTPUT ..... SERIAL NUMBER .....

## Commissioning Check Details

Pump Pressure (psi)  Smoke Reading  Flue Draft in W.G.

F.G.T. °C  Burner Model  Oil Type  CO<sub>2</sub>%

DATE ..... NAME ..... ADDRESS .....

COMMISSIONING COMPANY ..... .....

SIGNATURE ..... POSTCODE ..... TEL .....



For further information on Firebird Products  
please contact

**FIREBIRD UK**

Unit 6, Westover Industrial Estate, Ivybridge, Devon PL 21 9 ES.  
Tel: [+44] 01 752 691177 Fax: [+44] 01 752 691131

**FIREBIRD BOILERS**

Ballymakeera, Co. Cork.  
Tel: [+353] 026 45253 Fax: [+353] 026 45309

**FIREBIRD PRODUCTS**

Shean, Forkhill, Newry. BT35 9SY.  
Tel: [+44] 028 30888330 Fax: [+44] 028 30889096

Int. Access Codes: Eg. N.I. +44 28 30888330

© RJS 1 8 2004

© Copyright applies to all FIREBIRD products. Our policy is one of continual development and we therefore reserve the right to change without prior notice the specification of our products at any time and be without obligation to make similar changes in products previously produced.

Affix  
Stamp  
Here

.....

.....

.....

.....

.....