

# FIREBIRD

HEATING SOLUTIONS

## ENVIROMAX CONDENSING BOILERS TECHNICAL MANUAL

Combi HE  
Combipac HE  
Slimline Combi

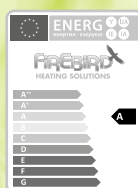
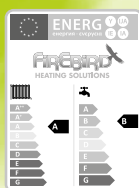

This manual must remain with the householder once installation is complete

*Working towards a greener planet*

## FOREWORD

We would like to thank you for purchasing a high efficiency Firebird condensing oil boiler. This instruction manual is produced for the reference and guidance of qualified installation engineers, preferably OFTEC (Oil Firing Technical Association) registered. EU legislation governs the manufacture, operation and efficiency of all domestic central heating oil boilers. Our boilers and burners are supplied as matched units.

	PAGE
<b>1. SAFETY</b> .....	2
<b>2. STANDARDS &amp; REGULATIONS</b> .....	3
2.1 Condensate Disposal .....	4
2.2 Flue Regulations .....	7
2.3 Flue Systems .....	10
2.4 Oil Supply .....	11
<b>3. COMBI HE &amp; COMBIPAC HE</b>	
3.1 Householder/End User Information .....	12
3.2 Installer Guidelines .....	13
3.3 Technical Details .....	17
<b>4. SLIMLINE COMBI</b>	
4.1 Householder/End User Information .....	21
4.2 Installer Guidelines .....	22
4.3 Technical Details .....	25
<b>5. COMMISSIONING &amp; BURNER SETTINGS</b> .....	28
<b>6. SERVICING</b> .....	31
<b>7. TERMS &amp; CONDITIONS OF WARRANTY</b> .....	32
<b>8. PRODUCT FICHE</b> .....	33

## HEALTH & SAFETY INFORMATION

The installer should be aware of his/her responsibilities under the current, local Health and Safety at Work Act. The interests of safety are best served if the boiler is installed and commissioned by a competent, qualified engineer, OFTEC trained and registered. If not, a Building Notice is required in England & Wales. Other parts of the British Isles, including the Channel Islands, also require notification to building control.

Under the Consumer Protection Act 1987 (UK), section 6 of the Health and Safety Act 1974 (UK) and the Safety, Health and Welfare at Work Act 2005 (ROI), we are required to provide information on substances hazardous to health.

### INSULATION AND SEALS

Ceramic Fibre, Alumino - Silicone Fibre material are used for boards, ropes and gaskets. Known hazards are that people may suffer reddening and itching of the skin. Fibre entering the eye will cause foreign body irritation. It may also cause irritation to the respiratory tract.

Precautions should be taken by people with a history of skin complaints or who may be particularly susceptible to irritation. High dust levels are only likely to arise following harsh abrasion. Suitable personal protective equipment should be worn where appropriate.

Generally, normal handling and use will not give discomfort. Follow good hygiene practices, wash hands before consuming food, drink or using the toilet.

First Aid - medical attention should be sought following eye contact or prolonged reddening of the skin.

The small quantities of adhesives and sealants used in the product are cured. They present no known hazards when used in the manner for which they are intended.

### THIS PRODUCT HAS BEEN DESIGNED TO THE FOLLOWING STANDARDS:

This equipment complies with the Low Voltage Directive 2006/95/EC & the EMC Directive 2004/108/EC.

**EMC** - conformity was demonstrated by meeting the following standards:

EN 55014-1: 2006/A2: 2011: Electromagnetic Compatibility - Requirements for Household Appliances, Electric Tools and Similar Apparatus - Part 1: Emission

EN 55014-2: 1997/A2: 2008: Electromagnetic Compatibility - Requirements for Household Appliances, Electric Tools and Similar Apparatus - Part 2: Immunity - Product Family Standard

EN 61000-3-2: 2009: Electromagnetic Compatibility (EMC) Part 3-2: Limits - Limits for Harmonic Current Emissions (equipment input current <16 A per phase)

EN 61000-3-3: 2008: Electromagnetic Compatibility (EMC) Part 3-3: Limits - Limitation of Voltage Changes, Voltage Fluctuations and Flicker in Public Low-voltage Supply Systems (equipment with rated current <16 A per phase and not subject to conditional connection)

**Safety** - conformity was demonstrated by meeting the following standards:

EN60335-1: 2012: Household and Similar Electrical Appliances - Safety - Part 1: General Requirements

EN60335-2-102: 2006/A1: 2010: Household and Similar Electrical Appliances - Safety - Part 2-102: Particular Requirements for Gas, Oil and Solid-fuel Burning Appliances having Electrical Connections

## SAFETY

Safe use of Kerosene. These fuels give off a flammable vapour when heated moderately. Vapour ignites easily, burns intensely and may cause explosion. The vapour can follow along at ground level for considerable distances from open containers and spillages collecting as an explosive mixture in drains, cellars, etc.

Fuels remove natural oils and fats from the skin and this may cause irritation and cracking of skin. Barrier cream containing lanolin is highly recommended together with good personal hygiene and where necessary appropriate personal protection equipment (P.P.E.).

Gas oil may also cause irreversible damage to health on prolonged or repeated skin contact.

Always store fuels in a properly constructed and labelled tank. Always handle fuel in open air or well ventilated space away from sources of ignition and refrain from smoking.

Always drain fuel using a proper fuel retriever, funnel or mechanical siphon. Never apply heat to a fuel tank, container or pipework. Never siphon fuel through tube by mouth.

Avoid inhaling fuel vapour as this can cause light headedness and seriously impair judgement.

## FUEL SPILLAGE

1. Switch off all electrical and other ignition sources.
2. Remove all contaminated clothing to safeguard against fire risk and skin damage. Wash affected skin thoroughly with soap and water and remove clothing to a safe well ventilated area and allow to air before cleaning.
3. Contain and smother the spill using sand or other suitable oil absorbent media or non-combustible material.
4. Do not allow fuel to escape into drains or water courses. If this happens, contact the relevant authorities in your area (Ireland).
5. Consult local authority about disposal of contaminated soil.

## FIRST AID

If fuel is accidentally swallowed:

\* Seek medical attention immediately.

Do **NOT** induce vomiting.

If fuel is splashed into eyes:

\* Wash out with running water for at least ten minutes and seek medical attention.

**To ensure the highest standards of installation & safety, it is important that the boiler be installed in compliance with the following regulations where applicable. It is the responsibility of the installer and everyone concerned with any aspect of installation, to ensure that all applicable, current standards and regulations are fully adhered to.**

The following is a list of some of the applicable standards and regulations. Please always check for the most up to date version.

Part L & J	Ireland, United Kingdom and Northern Ireland.
Part F	Section III Scotland - Conservation of Fuel Power
BS 5410	Part 1: 2014 - Code of Practice for Oil Firing - Installation up to 44kW Part 2: 2013 - Code of Practice for Oil Firing - Installation for 44kW and greater
BS 799	Part 5: 2010 - Specification for Oil Storage Tanks
BS 4876: 1984	Performance Requirements for Oil Burning Appliances
EN 12828: 2012 + A1: 2014.	(UK National Annex) - Heating Systems in Buildings - Design for Water Based Heating Systems
BS 7074	Part 1: 1989 - Application, Selection and Installation of Expansion Vessels and Ancillary Equipment for Sealed Water Systems
BS 7593: 2006	Code of Practice for Treatment of Water in Heating Systems
BS 715: 1989	Metal Flue Pipes, Fittings, Terminals and Accessories
BS 1181: 1989	Clay Flue Linings and Flue Terminals
BS 4543	Part 3: 1990 - Factory made Insulated Chimneys for Oil Fired Appliances
BS 8558	Design, Installation, Testing and Maintenance of Services Supplying Water
BS 7671	Current IEE Regulations - Requirements for Electrical Regulations
	Local Water Undertaking Bylaws - Water Supply (Water Fittings) Regulations 1999 - The Control of Pollution (Oil) Regulations
BS EN 304: 1992	Heating Boilers - Test Code for Heating Boilers for Atomizing Oil Burners

**In addition, the work must comply with relevant building regulations for oil fired boilers and oil storage tanks.**

**OFTEC publish excellent guides including:** Safe working practices for Oil Fired Technicians' - OFTEC Technical Book Three (Installation requirements for Oil Fired Boilers and Oil Storage Tanks) - OFTEC Technical Book Four (Domestic Heating Systems) and it is recommended that these should adhere to Domestic Heating Design Guide.

COPIES OF BRITISH STANDARDS MAY  
BE PURCHASED DIRECT FROM:

**BSI (Customer Services),  
389 Chiswick High Rd., London W4 4AL.  
Tel.: +44 (0)845 0869001 Fax: +44 (0)208 9967001**  
International and EC Standards are also available from above.

OFTEC PUBLICATIONS ARE AVAILABLE FROM:-  
**OFTEC, Oil Firing Technical Association,  
Foxwood House, Dobbs Lane,  
Kesgrave, Ipswich, IP5 2QQ.  
www.oftec.org**

### **BOILER INSTALLATION:**

Other than special considerations for condensate removal and plume dispersal, the installation of oil fired condensing boilers is the same as for non-condensing oil fired boilers.

BS5410 - Part 1: 2014 gives the requirements for domestic boiler and oil storage installations.

If an appliance is to be installed inside a building or within a restricted area externally, a carbon monoxide detector alarm conforming to EN 50291 should be installed in accordance with the manufacturer's instructions.

For condensing boilers, the same requirements apply for installation with regard to cleaning and flushing and providing inhibitors, as are followed for any other boiler. Manufacturer's instructions must always be followed together with the requirements of EN 12828: 2012 + A1: 2014 & EN 12831: 2003 and the statutory requirements of the Building Regulations.

## 2 2.1 - STANDARDS & REGULATIONS - CONDENSATE DISPOSAL

Firebird condensing boilers, when in condensing mode, extract more heat from the flue products and the resulting condensate which is mildly acidic, needs to be drained from the boiler via a condensate pipe to the drainage system.

**Provision must be made for the removal of condensate from the boiler to an internal soil stack, waste pipe, external soil stack, gully or soak-away, as per BS 6798: 2014.**

The condensate trap is provided with the boiler and situated on the front of the boiler (under the cleaning door). This should be checked at regular intervals and cleaned during annual service.

The condensate line should:

- be plastic and have a minimum diameter of 22mm dia.;
- have a fall from the boiler of 1:100 minimum;
- have as few bends as possible to reduce the risk of trapping condensate.

**Copper or steel cannot be used.**

**CONDENSATE PIPEWORK THAT IS EXTERNAL OR IN AN UNHEATED GARAGE SHOULD NOT EXCEED 3 METERS AND SHOULD BE LAGGED WITH WATER PROOF INSULATION TO PREVENT FREEZING.**

### SYSTEM NO. 1 CONDENSATE TRAP Always prime condensate trap with water.

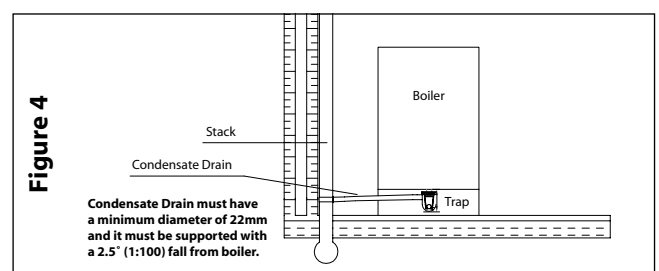
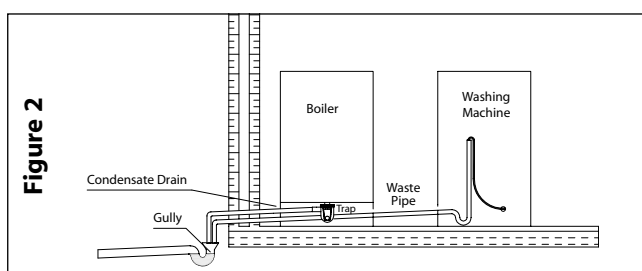
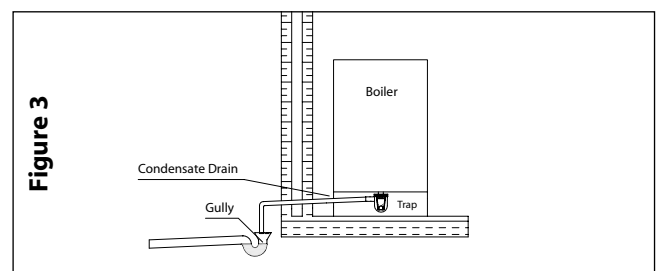
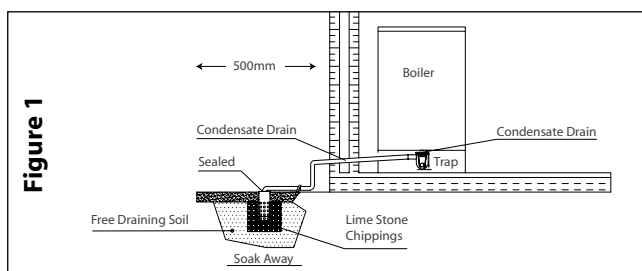
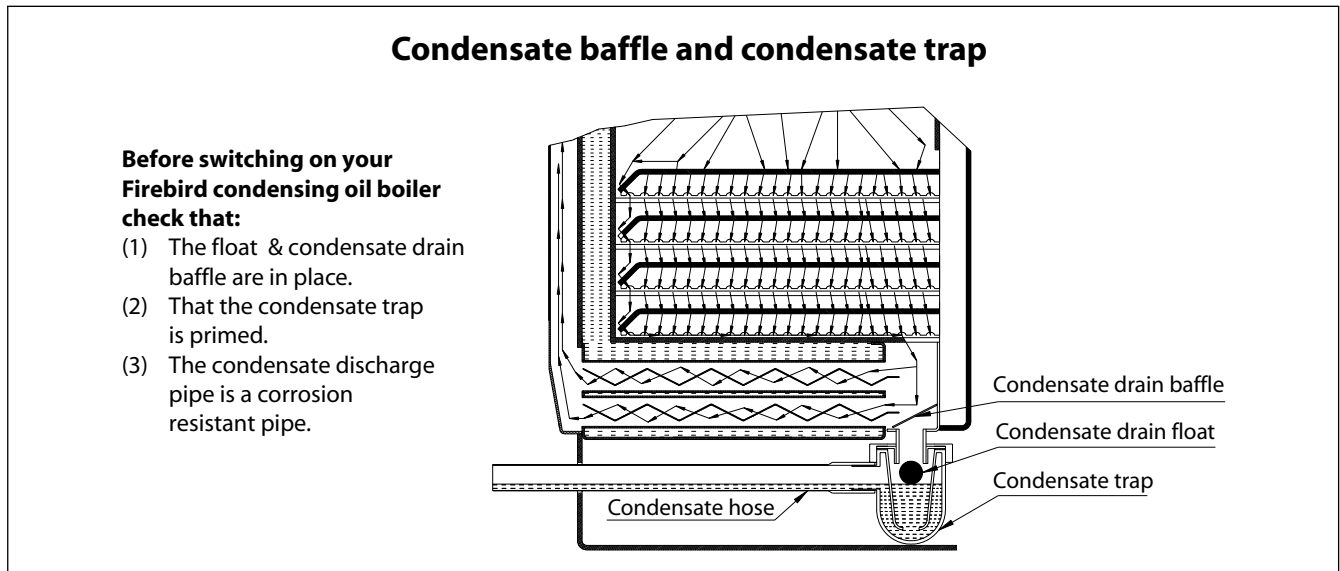

Ensure that the boiler combustion chamber cannot be filled through the condensate trap from another appliance (eg. washing machine) which is drained at a higher level (see Figure 2).

**SYSTEM NO. 2 - CONDENSATE PUMP**

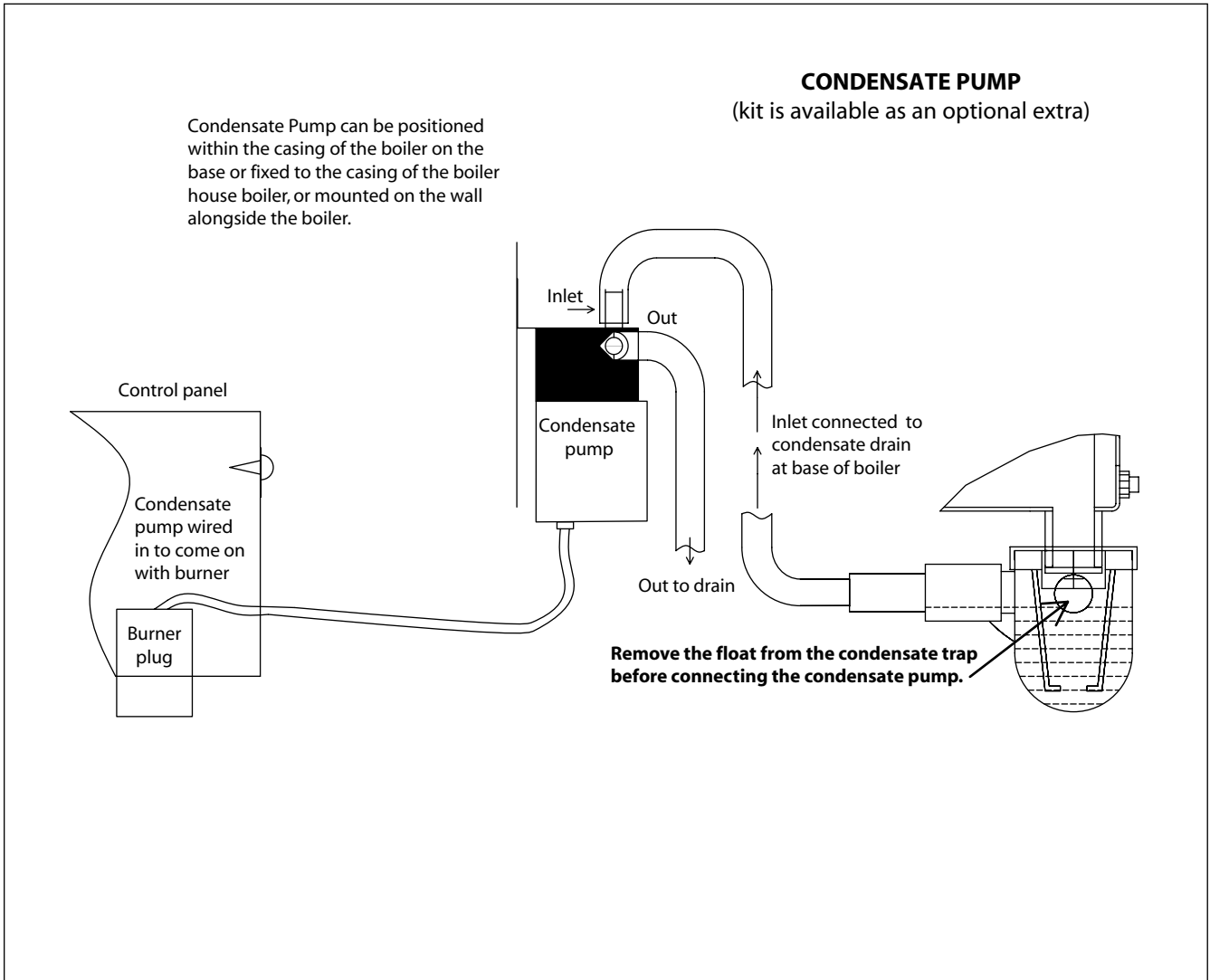

**Condensate Trap Fitting**

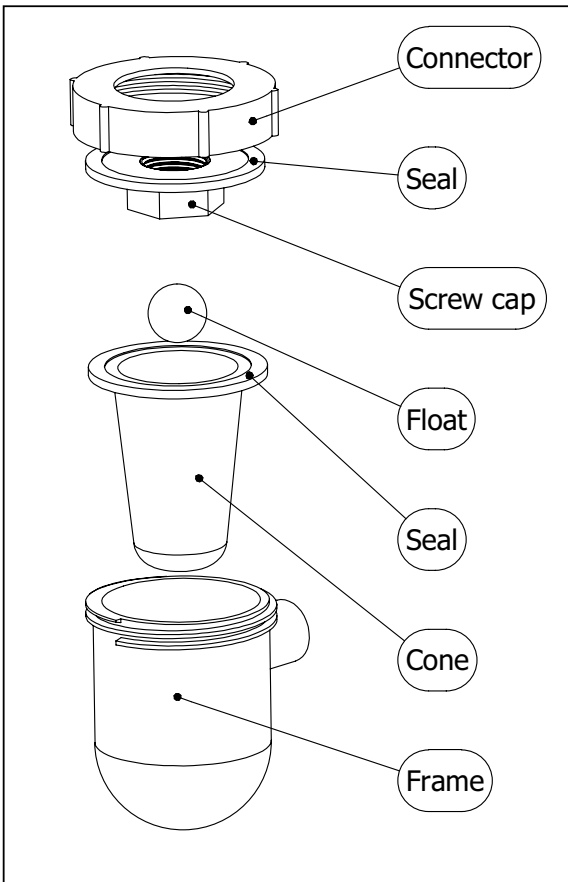

1. Push screw cap into connector and screw onto socket.

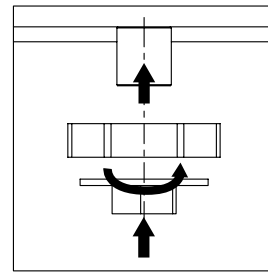

2. Place cone into frame and float into cone.

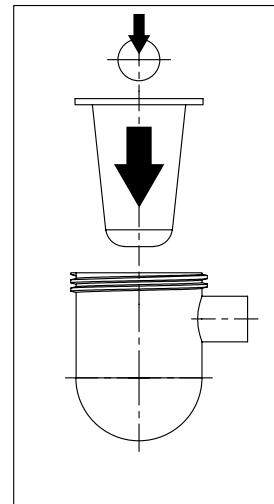

3. Screw frame with cone and float into connector.

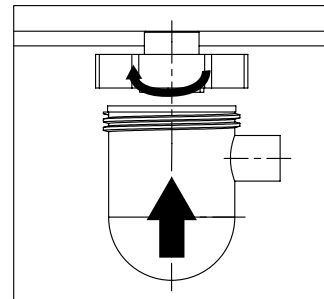

4. Push flexible pipe onto frame socket.

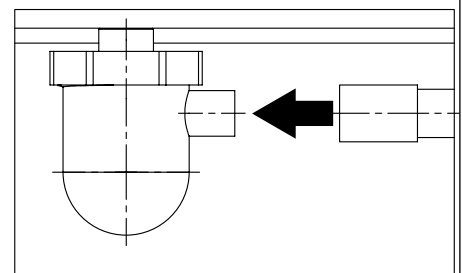

5. Final assembly.

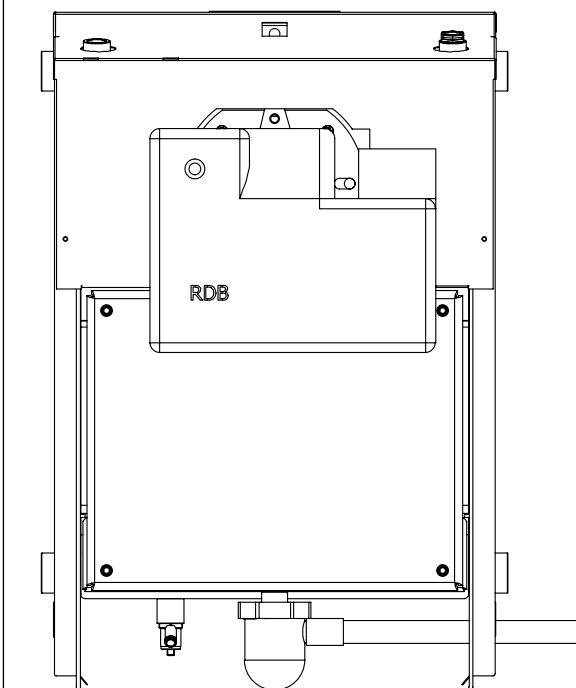
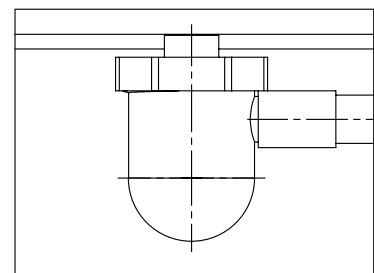

## 2 2.2 - STANDARDS & REGULATIONS - FLUE REGULATIONS

### BALANCED FLUE SITING

The terminal should be positioned to avoid combustion products entering the building or accumulating in stagnant pockets around buildings. The terminal must be protected by a guard if it is less than 2 metres above ground level or in a position where any person has access to it (i.e. a balcony). A heat protection shield should be fitted if the terminal is less than 850mm from a plastic or painted gutter or less than 450mm from painted eaves. Prevailing winds should be taken into account when siting a flue.

**ALWAYS CHECK FOR ANY BUILDING REGULATIONS AMENDMENTS WHICH MAY HAVE BEEN ISSUED AFTER THE PUBLICATION OF THIS MANUAL**

### Clearances advised by BS 5410 Part 1: 2014

#### Regular Appliance (Open, Low Level Discharge and Balanced) Flue Termination Clearance

The basic requirement with regard to flue positioning is that no hazard or nuisance is caused by the flue gases. Diagrams 20a and 20b show clearances advised by BS 5410 Part 1: 2014.

Regional requirements where flue clearances differ can be found in the regional requirements section in OFTEC Book 3 2010.

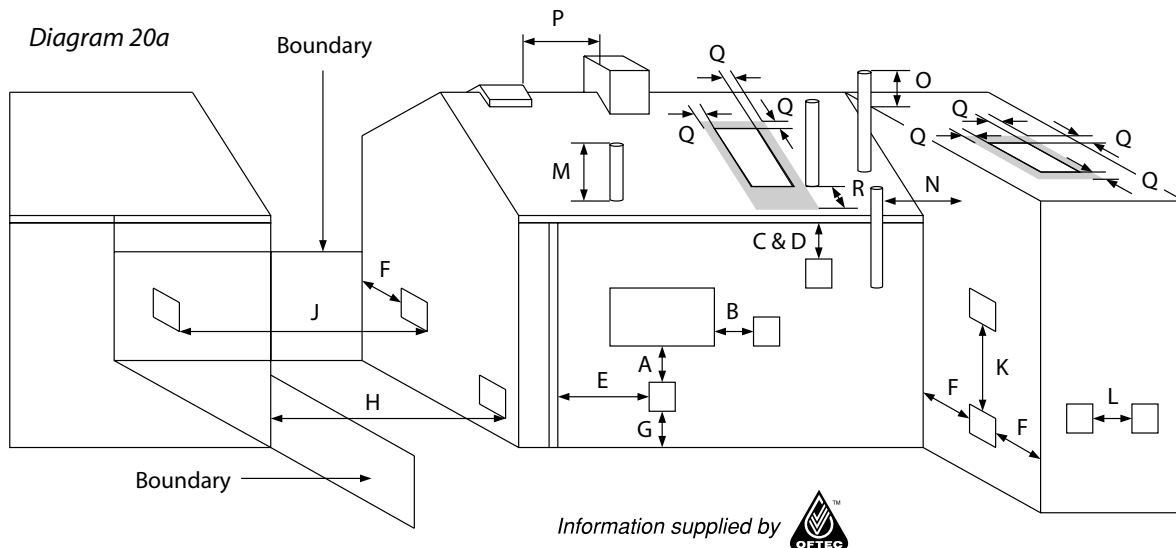

#### Minimum distances to terminals in millimeters as measured from the top of the chimney or the outer edge of where flue gases pass through low level discharge openings

	Location	Appliance Burner Type	
		Pressure Jet	
		Condensing	
		UK	ROI & NI
A	Directly below an opening, airbrick, opening window etc.	1000mm	600mm
B	Horizontally to an opening, airbrick, opening window etc.	1000mm	600mm
C	Below a gutter, eaves or balcony with protection	1000mm	1000mm
D	Below a gutter or a balcony without protection	1000mm	1000mm
E	From vertical sanitary pipe work	300mm	300mm
F	From an internal or external corner or surface or boundary alongside the terminal	300mm	600mm
G	Above ground or balcony level	300mm	300mm
H	From a surface or a boundary facing the terminal	1200mm	1200mm
J	From a terminal facing the terminal	2500mm	2500mm
K	Vertically from a terminal on the same wall	1500mm	1500mm
L	Horizontally from a terminal on the same wall	750mm	750mm
M	Above the highest point of an intersection with the roof	600mm	600mm
N	From a vertical structure on the side of the terminal	750mm	750mm
O	Above a vertical structure less than 750mm from the side of the terminal	600mm	600mm
P	From a ridge terminal to a vertical structure on the roof	1500mm	1500mm
Q	Above or to the side of any opening on a flat or sloping roof	300mm	300mm
R	Below any opening on a sloping roof	1000mm	1000mm

## 2 2.2 - STANDARDS & REGULATIONS - FLUE REGULATIONS

**NOTES: These notes form an integral part of the information shown on the previous page.**

1. Terminals should be positioned to avoid products of combustion accumulating in stagnant pockets around the building, or entering into buildings.
2. Appliances burning Class D oil have additional restrictions (see OFTEC Book 3 2010).
3. Vertical structures in N, O and P include lift rooms, parapets, dormers etc.
4. Terminating positions A to L are only permitted for appliances that have been approved for low level flue and low level balanced flue discharge when tested to BS EN 303-1.
5. Terminating positions must be at least 1.8m distant from an oil storage tank unless a wall with at least 30 minutes fire resistance and extending 300mm higher and wider than the oil storage tank is provided between the oil storage tank and the terminating position.
6. Where a flue is terminated less than 1m away from a projection above it and the projection consists of plastic or has a combustible or painted surface, then a heat shield of at least 750mm wide should be fitted to protect these surfaces.
7. If the lowest part of the terminal is less than 2m above the ground, balcony, flat roof or other place to which any person has access, the terminal must be protected by a guard.
8. Notwithstanding the dimensions given in the diagram and table, a terminal should not be sited closer than 300mm to combustible material.
9. It is essential that a flue or chimney does not pass through the roof within the shaded area shown by dimensions Q and R.
10. Where protection is provided for plastic components, such as guttering, it is essential that this is to the standard specified by the manufacturer of the plastic components.

Diagram 20b

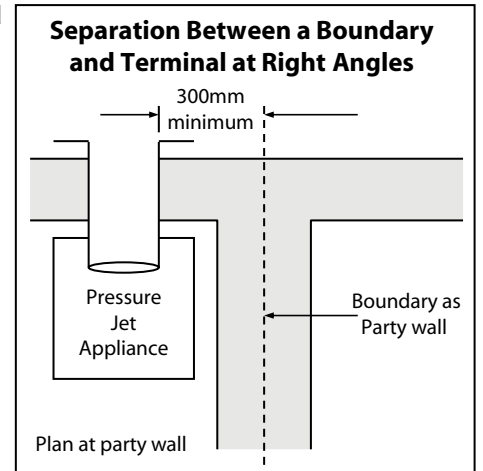

### BALANCED FLUE BOILERS

The Firebird boiler may be set for room-sealed flue operation using a Firebird condensing balanced flue kit. This kit does **not** draw **combustion air** from inside the room. **It is drawn from outside, direct to the burner by an air pipe supplied with the boiler.** Flue gases are expelled through the same kit. However, if the boiler is installed in a **compartment** or **small room**, some **ventilation air** is necessary to maintain an acceptable temperature in the boiler area.

**Balanced flue boiler in room does not require individual ventilation.**

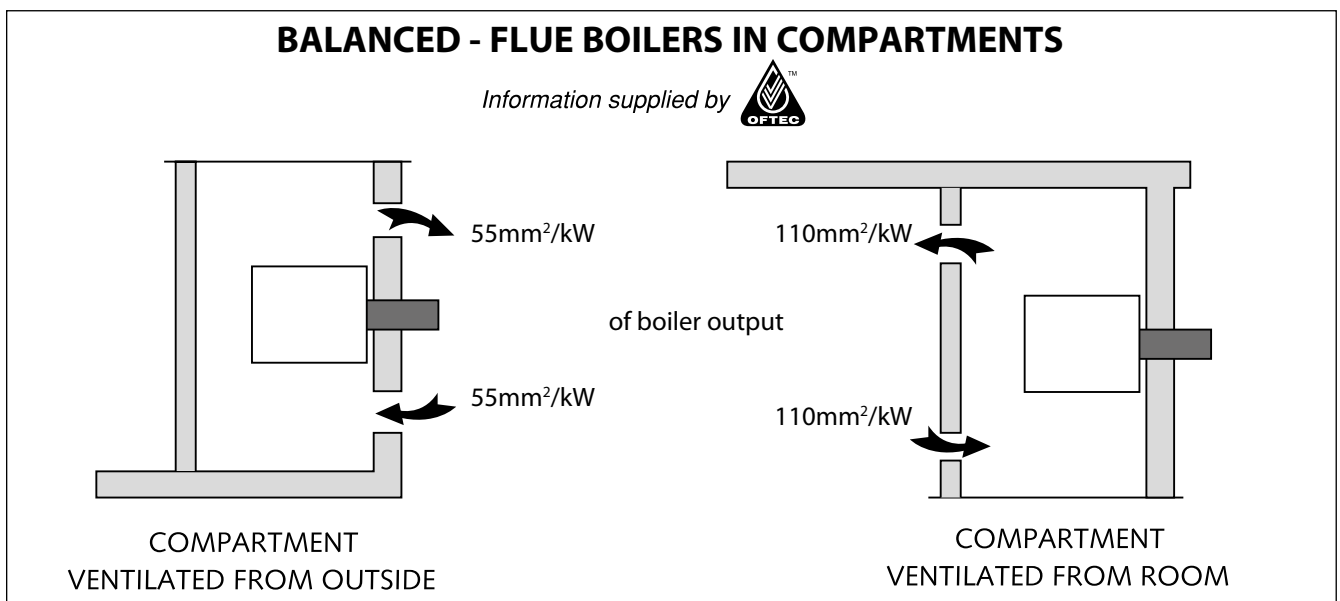

### CONDENSATE PLUME DISPERSAL

When choosing the location for a condensing boiler, special consideration must be given to the positioning of the flue terminal. Care should be taken to locate it so as to prevent either the end user or their neighbours perceiving the plume to be a nuisance.

It should be noted that the normal statutory clearances required around low level flue terminals may not be sufficient to cope with plume dispersal from a condensing boiler. The following points should be considered:

1. Plumes can extend out horizontally and can also drift out to the sides and above the terminal. Care needs to be taken, therefore, to avoid the plume reaching adjacent surfaces, particularly windows and neighbours dwellings.
2. Flue terminals need to be located where air can pass freely across them to disperse vapours.
3. The effect of the moisture generated must be considered in relation to the possible corrosion of metal parts it might reach and to the possible formation of ice on pathways in freezing conditions.
4. Keep flue terminals a minimum of 1 m (horizontally) from openings in the building.
5. Do not install flue terminals directly below a window.
6. Do not install flue terminals next to a door.
7. Do not install flue terminals within 1 m of ventilated soffits or eaves.
8. Keep flue terminals at least 2.5m away from a surface or boundary facing the terminal.
9. In certain circumstances the installation of a plume dispersal extension to the flue may be unavoidable. This takes the plume exhaust from the boiler up and away from any obstruction, door or window opening and will also prevent the risk of re circulation of the plume gasses into the air intake of the burner.

**Please note that only Firebird flue kits should be used for flue installations.**

**CONDENSING BOILER CHIMNEY INSTALLATION**

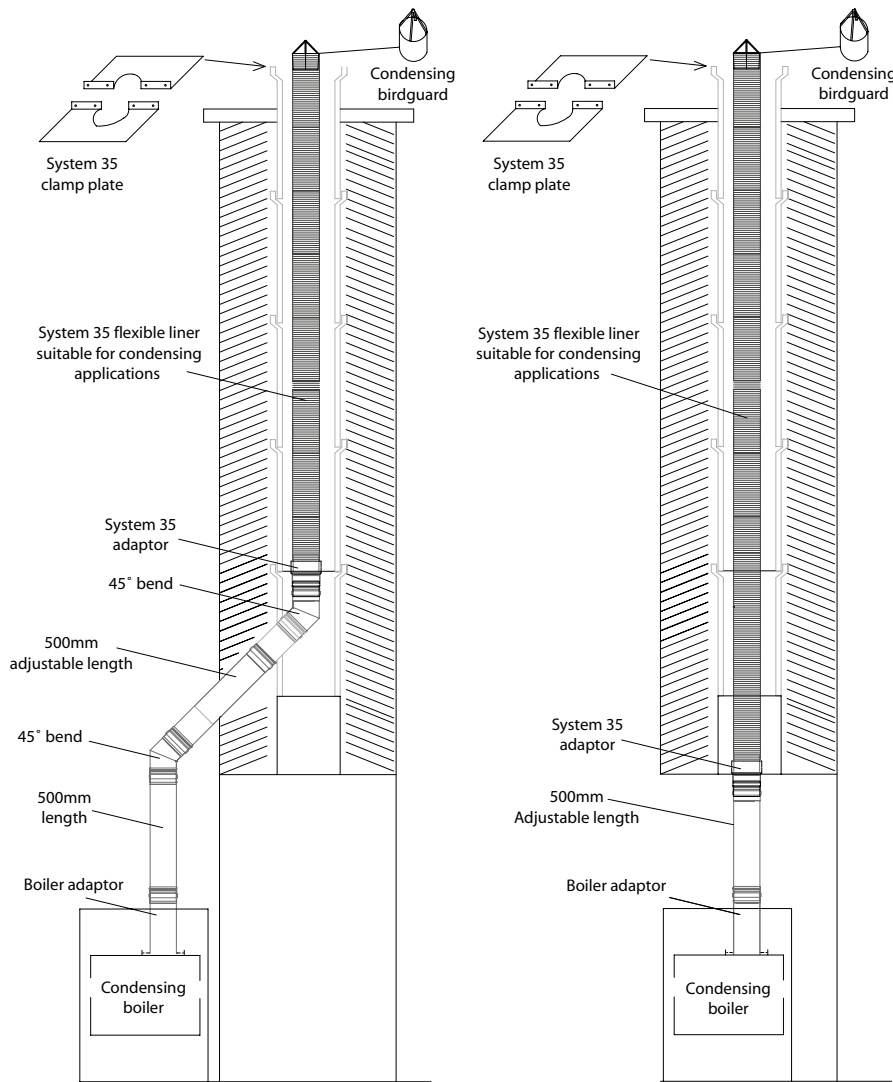

**PLUME KIT**

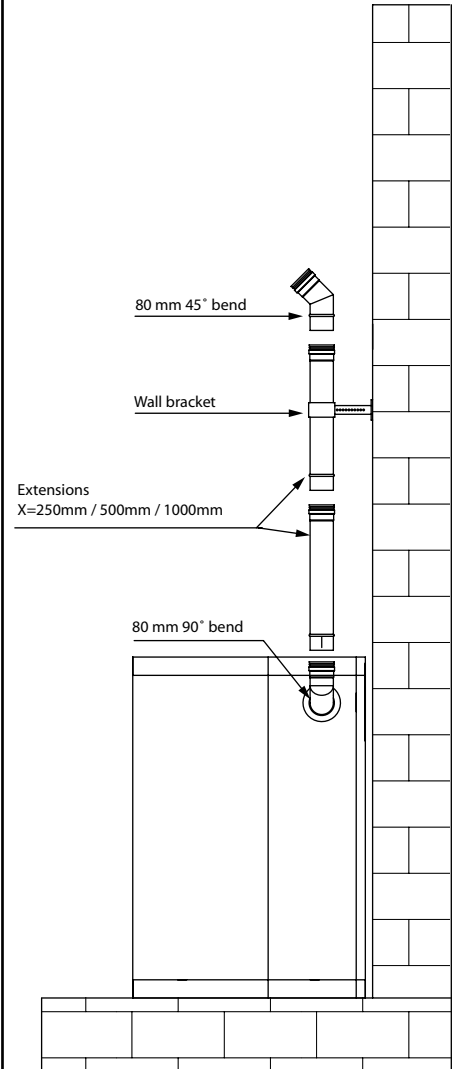

**FLUE SIZE**

Boiler	Diameter
12-18kW	100mm
12-20kW	100mm
20-26kW	100mm
26-35kW	100mm
35-44kW	100mm
44-58kW	100mm

**Single wall stainless flue suitable for condensing boilers. Available in stainless steel finish or white finish**

**NOTE:**  
**All brick chimney constructions must comply with current building regulations and BS 5410 Part 1: 2014. Insulated factory made chimneys should comply with BS 4543.**

### OIL STORAGE TANK SITING

Consult OFTEC Manuals

It is unlikely that a fire will start at an oil tank. However, the stored fuel must be protected from a fire or heat source that originates nearby. For this reason oil tanks of up to 2,500 litres should be separated from openings, other than airbricks, in the building by a minimum of 1.8m and a non-fire rated boundary by a minimum of 760mm. Where this cannot be achieved, a 30 minute fire rated barrier should be constructed between the hazard and the tank, which extends a minimum of 300mm higher and 300mm past each end of the tank. Note that a minimum separation distance should be maintained between a flue exit and fire barrier (see page 10 (flue systems)).

Steel tanks must be mounted on brick or block piers with a waterproof membrane between the piers and tank.

**Oil storage tanks should not be sited within 1.8m of boiler flue outlets.**

Do not allow household waste or hot ashes container in vicinity of oil storage tank or boiler flue outlet.

### FLEXIBLE OIL PIPE(S)

A flexible burner oil hose is supplied with the boiler which must be wholly contained within the appliance case.

**Please note: A filter must not be fitted inside the boiler and all joints in the oil line must be oil tight. Soldered joints are not permissible. Before connecting to the boiler, always flush the complete oil supply line and ensure that oil supply is completely clean and free of any dirt or foreign matter.**

### OIL LINE CONFIGURATION

Refer to burner manual section on Hydraulic Systems for:

- Two pipe systems.
- Pipe sizing & distance.
- Tank heights.
- Pump priming.

### REGULATIONS & STANDARDS

In **England and Wales**, installation in single family dwellings have to comply with the building Regulations Part J. This requires compliance with BS 5410 Part 1 : 2014. All tanks either deemed to be at risk or with a capacity of more than 2,500 litres will require to be banded.

For installation in **Scotland**, Building Standard Part F applies. This requires compliance with BS 5410 Part 1: 2014 and BS 5410 Part 2: 2013. All tanks either deemed to be at risk or with a capacity of more than 2,500 litres will require to be banded.

Those externally installed tanks with a capacity of less than 2,500 litres will require a bund if located not more than 50 metres from a spring or bore hole, 10 metres from controlled waters and additionally where it may constitute a hazard.

The above risks and hazards are described in OFTEC book 3.

In **Northern Ireland**, the Building Regulations do not currently cover the installation of oil storage tanks.

In the **Republic of Ireland** the requirements of BS 5410 Part 1: 2014 and BS 5410 Part 2: 2013 are required to be complied with by Building Regulations Part J.

### 3 3.1 COMBI HE & COMBIPAC HE - HOUSEHOLDER/END USER INFORMATION

Please consult with your installer regarding the operation of your boiler. This should include timer operation/room thermostat operation and any other additional operational features.

The basic features of the control panel are outlined below.

#### COMBI HE

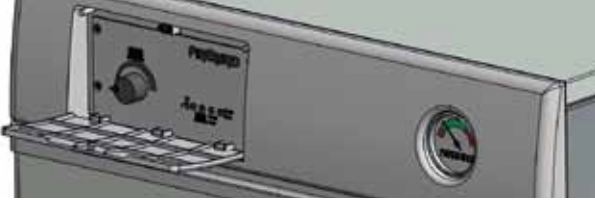

#### COMBIPAC HE



Maximum



Maximum



Medium



Medium



Minimum



Minimum

#### BOILER THERMOSTAT/THERMISTOR FUNCTION

The control thermostat on the boiler allows the householder to vary temperature to central heating from a low of 60°C to 80°C, depending on the model. Thermostats have a tolerance of + 4°C.

In accordance with EU boiler standards, your boiler is also fitted with a safety high limit thermostat, fixed at 110°C. This system protects the boiler in the event of the control thermostat failing and keeps the boiler safe.

The safety high limit thermostat will shut the boiler off and will require the limit button to be pushed to restart the boiler. It is recommended to call a service engineer to establish the cause.

#### BURNER LOCKOUT

The boiler is factory fitted with a burner control box lockout safety feature which operates automatically if a fault occurs in the burner operation. Should this occur, the light on the front of the burner will illuminate.

This could be caused by:

- A. An interruption in the fuel supply (eg. empty oil supply tank).
- B. An electrical supply fault.
- C. A fault with the burner or its safety control system.
- D. The failure of a burner component.
- E. Worn or dirty oil nozzle.
- F. Incorrect flue installation.

Before attempting to restart the boiler, the front panel and the burner cover should be removed and a visual check made for any obvious problems such as oil leaks, loose connections etc. This should be done by a service engineer.

## 3 3.2 COMBI HE & COMBIPAC HE - INSTALLER GUIDELINES

Please note the following important points before commencing installation.

Installation should only be carried out by a competent, qualified engineer, familiar with the installation of the Firebird boilers referred to in this manual.

### WARNING

The manufacturer cannot accept responsibility for any damage to persons, animals or property due to error in installation or in the burner adjustment or due to improper or unreasonable use or non-observance of the technical instruction enclosed with the burner, or due to the intervention of unqualified personnel.

### POSITIONING THE BOILER

Compliance guide to part L now states that when installing a boiler on a new or existing system, the system should be cleaned, flushed and then protected with a suitable protection inhibitor.

Ensure that adequate clearance is available for making the water and flue connections.

The boiler is serviced from the front and a clearance of 750mm must be available at the front of the boiler.

No special hearth is required as the boiler is fully insulated, but the floor must be level and capable of supporting the weight of the boiler and its water content.

Sound levels must also be a consideration. Whilst Firebird condensing oil boilers are one of the quietest boilers on the market, some householders are particularly sensitive.

**A suitable corrosion inhibitor must be added to the heating system.**

### UNDERFLOOR HEATING

The boiler should not be directly connected to underfloor heating, as a minimum return temperature of 37° is required (it can be used with underfloor heating with adequate temperature controls to ensure return values are as stated above).

### PLASTIC PIPING

The boiler thermostat control and safety system is not designed, and must not be relied on, to protect plastic pipe from overheating. Plastic pipe must never be connected directly to the boiler and there must be at least 1 meter of copper pipe between the boiler and the first plastic connection. If you choose to use plastic pipe anywhere on your heating circuits, please consult the plastic pipe manufacturer for their instruction on how to ensure their product never overheats. Our boiler control and safety high limit thermostats are not designed to fulfil this function. **Firebird accepts no responsibility for failure of plastic piping and fittings for whatever reason.**

### PRESSURISED HEATING SYSTEM

The maximum operating working pressure is 2 bar when the system is at full operating temperature.

### MAGNETIC FILTRATION

It is recommended at the time of installation of this boiler, to install a permanent effective magnetic filter on the return pipework after the last radiator on the central heating system. This will maintain maximum operational efficiency and protect the boiler from the damaging, long-term effects of "magnetite" (black iron sludge). It is essential that the filter

is sized similar to the return pipework. The magnetic filter must be installed in accordance with the manufacturer's instructions and serviced annually.

### HARD WATER - LIMESCALE

On initial fill, where it is suspected that there is a high concentration of scale products, a suitable inhibitor must be used to protect the boiler and system. Check with local water authorities if in doubt (max. 200 ppm).

### PIPEWORK

Do not obstruct flue fitting with Pipework. Connect pipework as shown below.

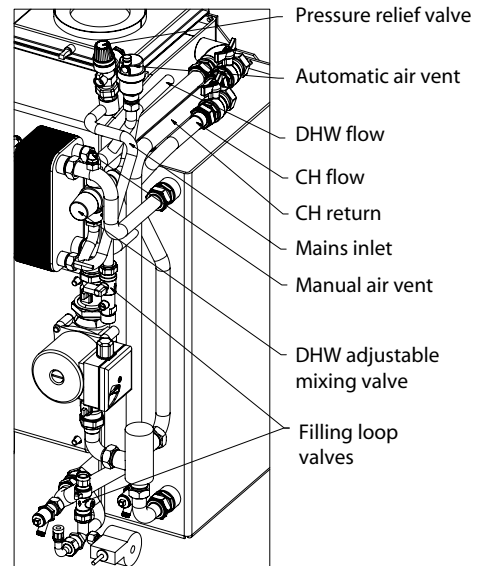

### FILLING THE SYSTEM

The unit comes with a factory fitted expansion vessel. Should the total water volume of the system exceed the expansion provided, a second vessel should be added (see below table).

#### Expansion Vessel and System Requirements

Safety Valve Setting	3 bar		
Initial System Pressure	0.5 bar	1.0 bar	1.5 bar
Total Water Content of System	Total Vessel Volume **		
Litres	Litres	Litres	Litres
25	2.1	2.7	3.9
50	4.2	5.4	7.8
75	6.3	8.2	11.7
100	8.3	10.9	15.6
125	10.4	13.6	19.5
150	12.5	16.3	23.4
175	14.7	19.1	27.2
200	16.7	21.8	31.2
225	18.7	24.5	35.1
250	20.8	27.2	39.0

FOR FURTHER INFORMATION, CONSULT APPROPRIATE TRAINING MANUALS, BS 7074 PART 1, EN 12828:2003 AND ANY OTHER RELEVANT STANDARDS & REGULATIONS.

\*\* When calculating the size of any additional expansion vessel, remember to deduct the boiler expansion vessel volume of 12 litres from the calculated total system vessel volume required, as given in the above table.

### 3 3.2 COMBI HE & COMBIPAC HE - INSTALLER GUIDELINES

#### FILLING LOOP

The diverter valve is factory set to "control heating mode" to facilitate system filling.

Connect the filling loop. Open both valves. Do not allow the unit to exceed 1 bar while filling and a maximum of 2 bar when the radiators are at full operating temperature. The automatic air vent will allow air to dispel from the boiler. To remove air from the storage tank, the manual air vent must be operated. When the system is full, turn off both valves and disconnect the filling loop.

#### CONNECTING OIL SUPPLY

Using the flexible hose provided, connect the burner to the incoming oil line which must have a remote acting fire valve. **The flexible hose must be contained within the appliance casing.**

#### WIRING

##### Electrical Supply

**The boiler and controls require a 230V 50Hz mains electric supply protected with a 5A fuse.**

**This appliance must be earthed.**

A qualified electrician must carry out all electric wiring in accordance with current ETCI / IET Regulations and any local regulations which may apply.

The boiler must have a permanent power supply to enable overrun and frost protection. The hot water and central heating should be timed separately.

#### THERMOSTAT TEMPERATURE CONTROL

Boiler Central Heating Control:	60°C - 80°C
Boiler Safety Limit:	110°C
Tank (DHW) - Fixed:	78°C
Early Alert - Fixed:	87°C
Over-run - Fixed:	93°C"

The Combipac HE has a build in frost protection (unit only).

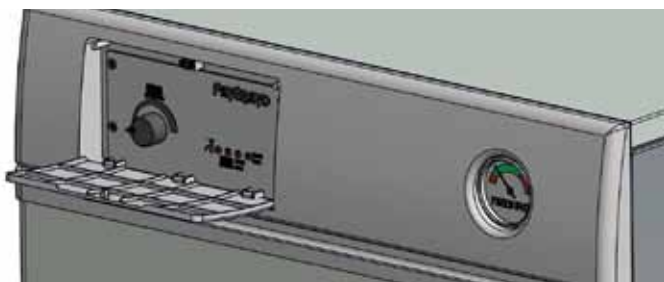
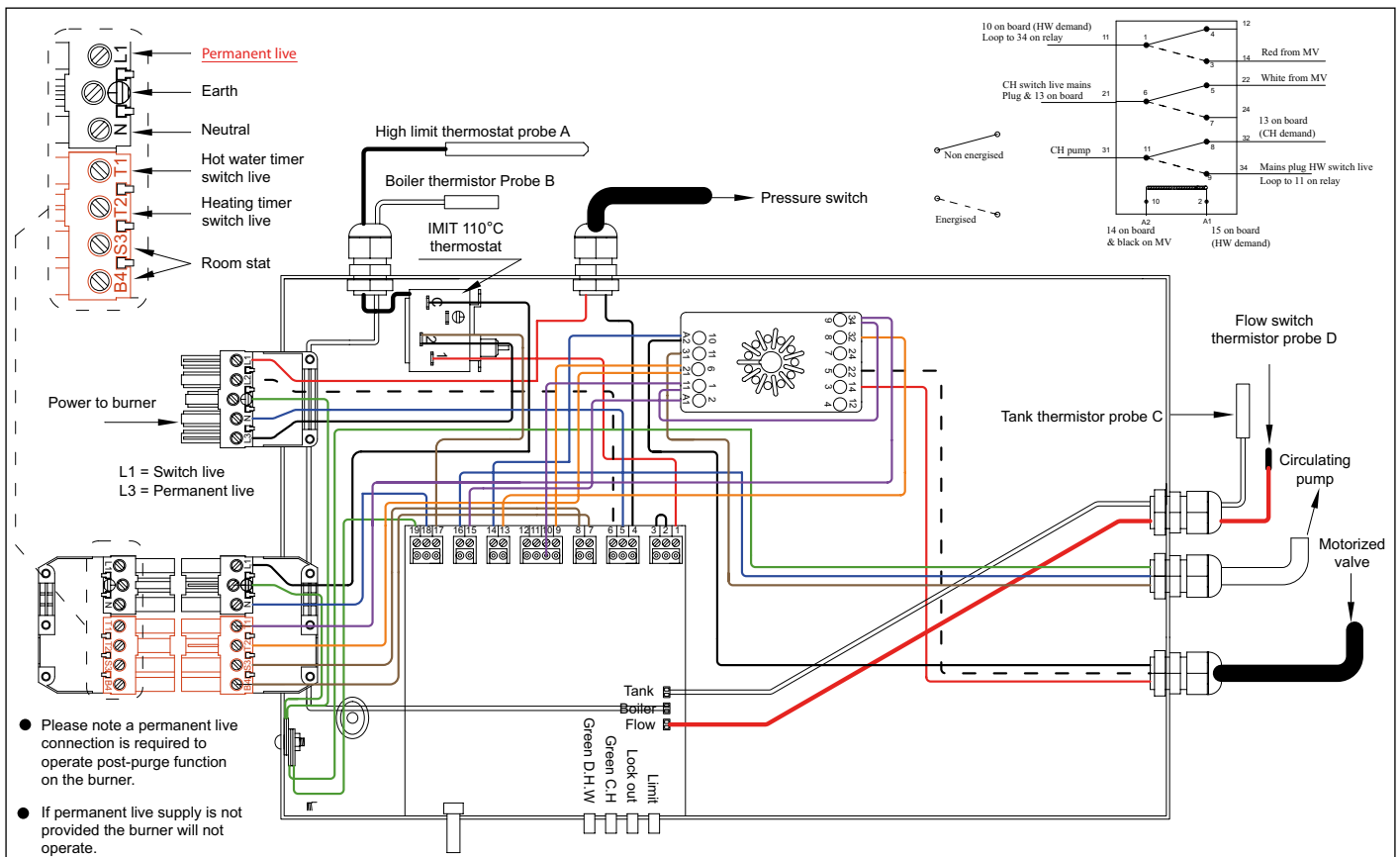

#### COMBI HE FLAP VALVE INSTALLATION

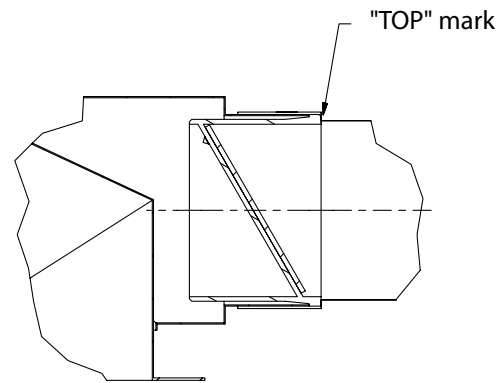
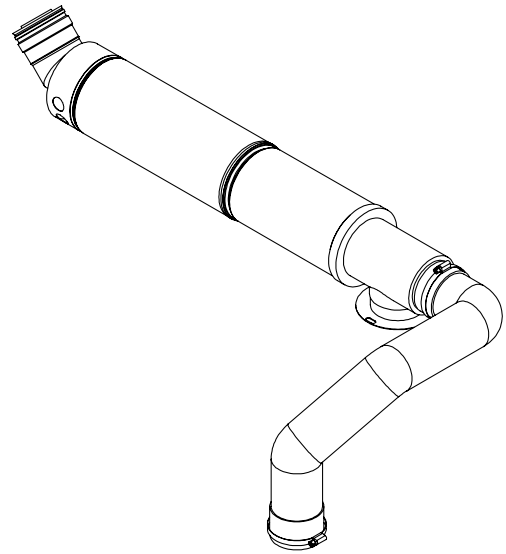
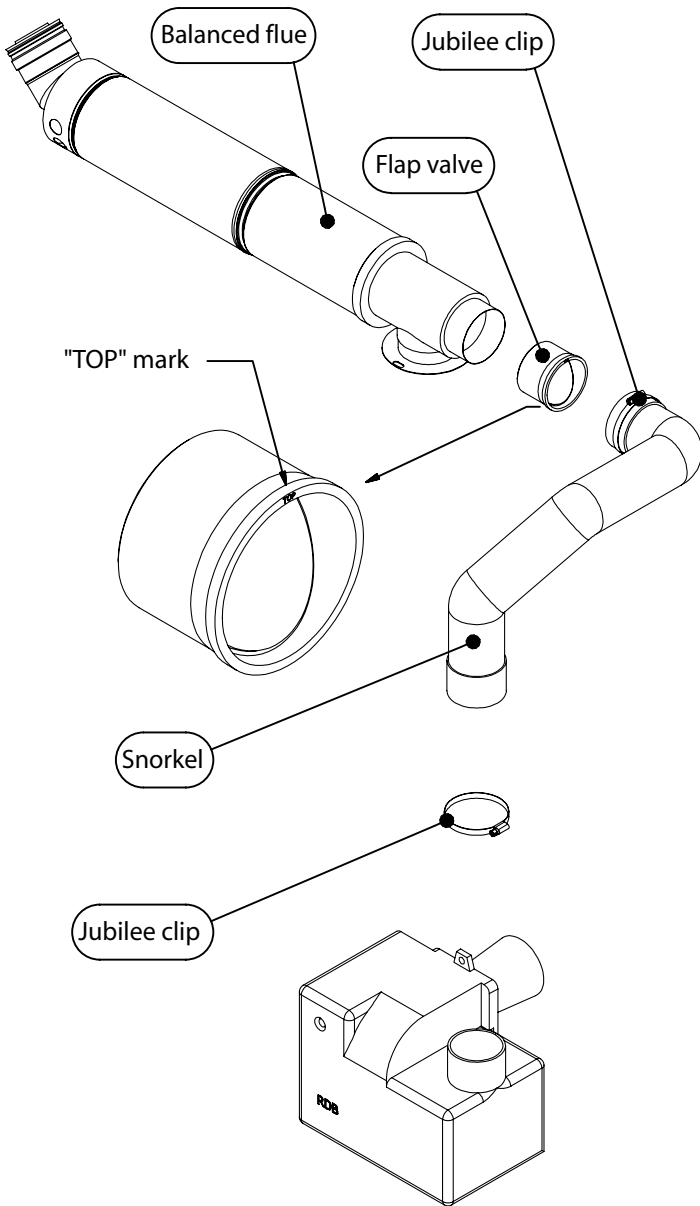

Correct position of flap valve

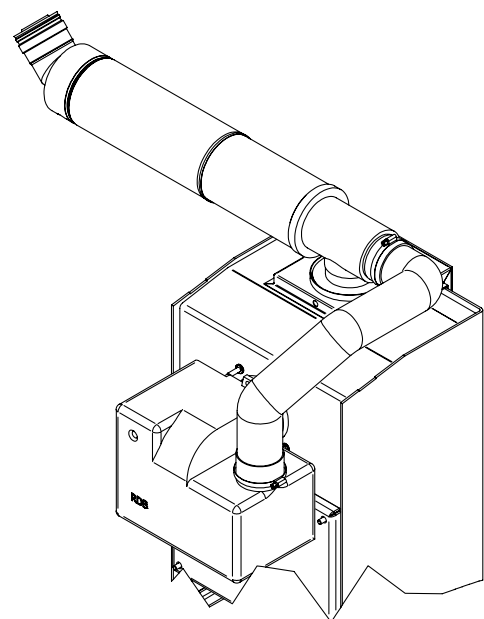

1. Push the flap valve into the balanced flue air intake.
2. Ensure that the flap valve is in the correct position.
3. Push the snorkel hose over the flap valve and air intake and secure with a jubilee clip.
4. Attach the other end of the snorkel hose to the burner with jubilee clip.

**COMBIPAC HE FLUE INSTALLATION**

**CONDENSATE PLUME DISPERSAL**

When choosing the location for a condensing boiler, special consideration must be given to the positioning of the flue terminal. Care should be taken to locate it so as to prevent either the end user or their neighbours perceiving the plume to be a nuisance.

It should be noted that the normal statutory clearances required around low level flue terminals may not be sufficient to cope with plume dispersal from a condensing boiler.

**INSTALLATION INSTRUCTIONS ARE SUPPLIED WITH ALL FLUE KITS**

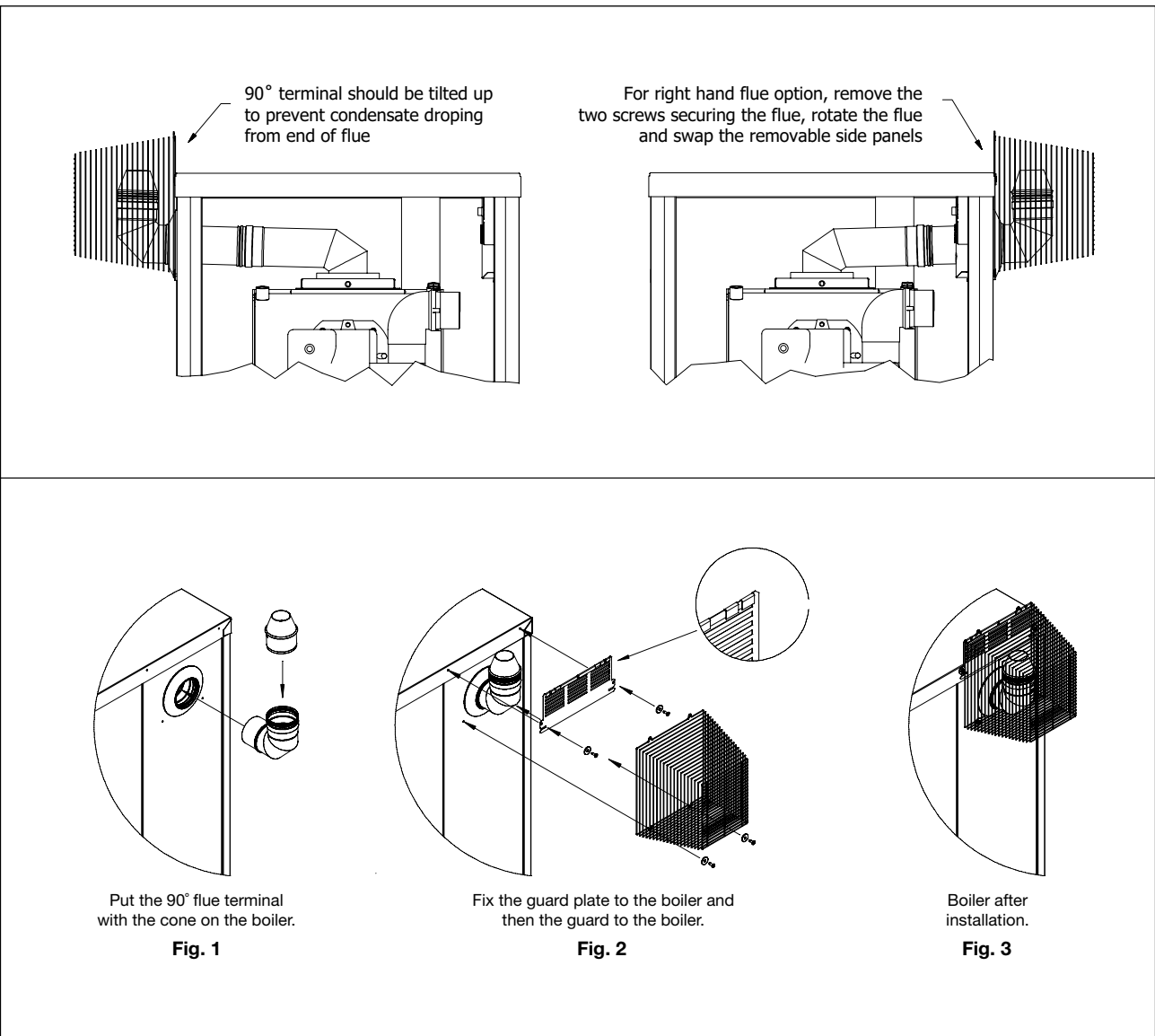

### 3 3.3 COMBI HE & COMBIPAC HE - TECHNICAL DETAILS

#### TECHNICAL DETAILS

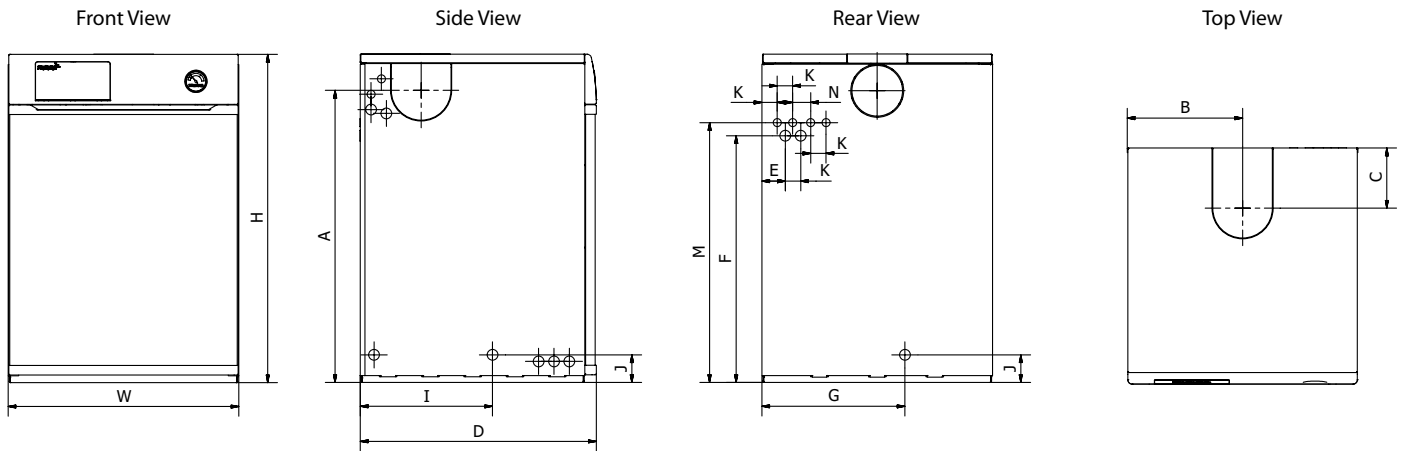

Model - Combi HE (output)	Weight kg	Dimensions (mm)													
		H	W	D	A	B	C	E	F	G	I	J	K	M	N
20kW	167	854	595	614	760	300	157	61	642	372	344	72	40	676	47
26kW	170	854	595	614	760	300	157	61	642	372	344	72	40	676	47
35kW	173	854	595	614	760	300	157	61	642	372	344	72	40	676	47

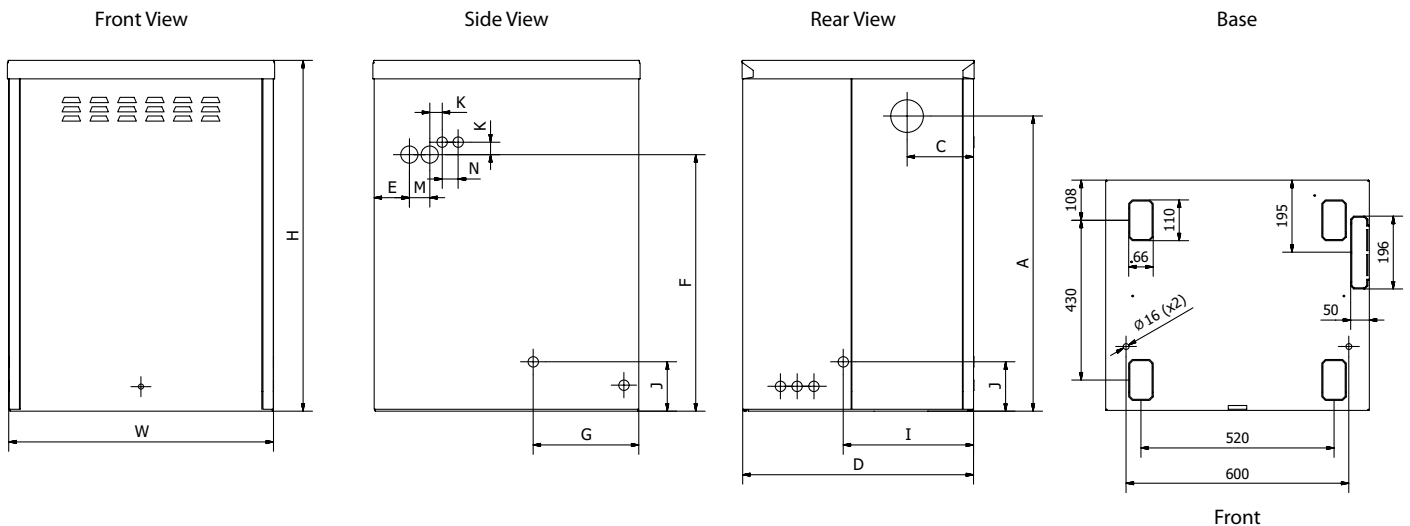

Model - Combipac HE (output)	Weight kg	Dimensions (mm)													
		H	W	D	A	C	E	F	G	I	J	K	M	N	
20kW	200	945	720	625	795	180	95	691	285	351	133	34	55	43	
26kW	200	945	720	625	795	180	95	691	285	351	133	34	55	43	
35kW	203	945	720	625	795	180	95	691	285	351	133	34	55	43	

### 3 3.3 COMBI HE & COMBIPAC HE - TECHNICAL DETAILS

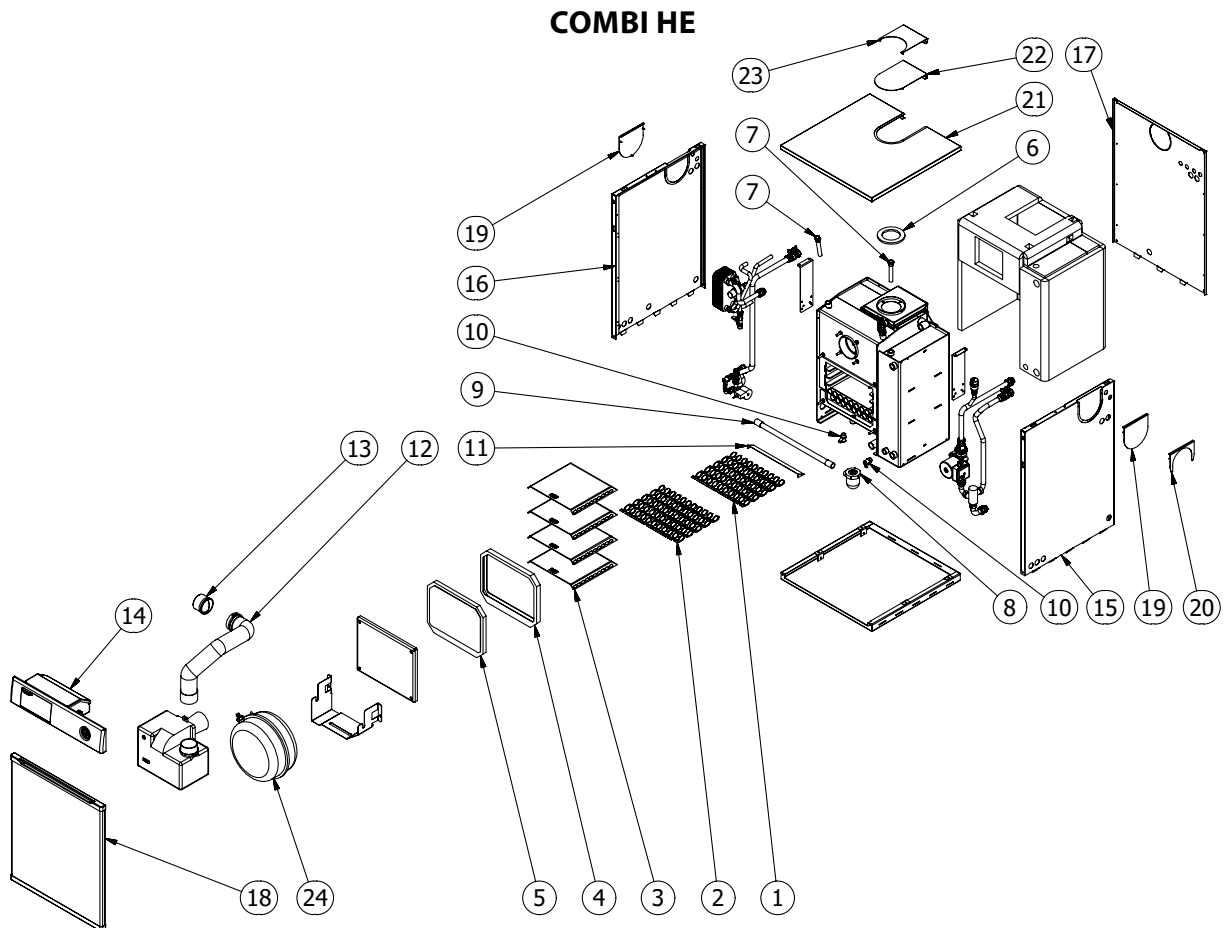

No.	Qty	Description	20kW	26kW	35kW
1	4	Tube baffle	BA110907	BA110907	BA110907
2	5	Tube baffle single	BA110908	BA110908	BA110908
3	4	Smoke baffle	BA212022	BA212028	BA212122
4	1	Door seal	ACC000DDS	ACC000DDS	ACC000DDS
5	1	Door duroboard	ACC000DDS	ACC000DDS	ACC000DDS
6	1	Flue gasket	ACC000FRG	ACC000FRG	ACC000FRG
7	1	Stat pocket	ACC003PKT	ACC003PKT	ACC003PKT
8	1	Condensate trap	ACC000TRP	ACC000TRP	ACC000TRP
9	1	Condensate hose	ACC000FLX	ACC000FLX	ACC000FLX
10	1	Drain cock	ACC012DRC	ACC012DRC	ACC012DRC
11	1	*Heat deflector	-	-	-
12	1	Air hose	ACC000SSH	ACC000SSH	ACC000SSH
13	1	Flap valve	ACC000FLP	ACC000FLP	ACC000FLP
14	1	Control panel	ACP001CCE	ACP001CCE	ACP001CCE
15	1	Casing right side	ACP002CCE	ACP002CCE	ACP002CCE
16	1	Casing left side	ACP003CCE	ACP003CCE	ACP003CCE
17	1	*Casing back	-	-	-
18	1	Casing front	ACP004CCE	ACP004CCE	ACP004CCE
19	2	*Side flue blank	-	-	-
20	1	*Side half moon blank	-	-	-
21	1	Casing top	ACP005CCE	ACP005CCE	ACP005CCE
22	1	*Top flue blank	-	-	-
23	1	*Top half moon blank	-	-	-
24	1	Pressure vessel	ACC012PVL	ACC012PVL	ACC012PVL

**For burner parts refer to burner manual.**  
**\*Contact Firebird if required.**

### 3 3.3 COMBI HE & COMBIPAC HE - TECHNICAL DETAILS

#### COMBIPAC HE

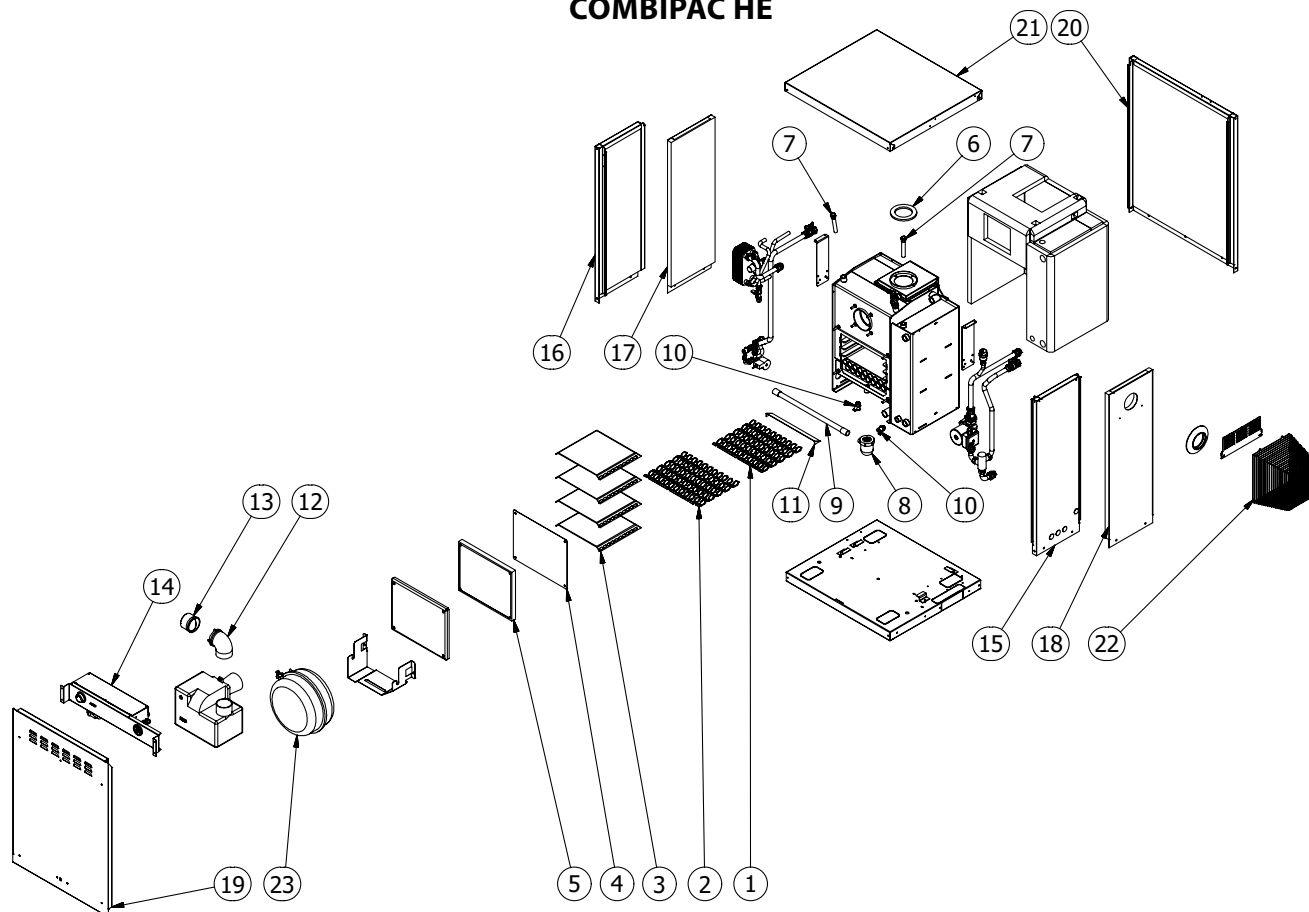

No.	Qty	Description	20kW	26kW	35kW
1	4	Tube baffle	BA110907	BA110907	BA110907
2	5	Tube baffle single	BA110908	BA110908	BA110908
3	4	Smoke baffle	BA212022	BA212028	BA212122
4	1	Door seal	ACC000DDS	ACC000DDS	ACC000DDS
5	1	Door duroboard	ACC000FRG	ACC000FRG	ACC000FRG
6	1	Flue gasket	ACC003PKT	ACC003PKT	ACC003PKT
7	1	Stat pocket	ACC000TRP	ACC000TRP	ACC000TRP
8	1	Condensate trap	ACC000FLX	ACC000FLX	ACC000FLX
9	1	Condensate hose	ACC012DRC	ACC012DRC	ACC012DRC
10	1	Drain cock	-	-	-
11	1	*Heat deflector	ACC000FVA	ACC000FVA	ACC000FVA
12	1	Flap valve adapter	ACC000FLP	ACC000FLP	ACC000FLP
13	1	Flap valve	ACP001CCP	ACP001CCP	ACP001CCP
14	1	Control panel	ACP002CCP	ACP002CCP	ACP002CCP
15	1	Casing fixed right side	ACP003CCP	ACP003CCP	ACP003CCP
16	1	Casing fixed left side	ACP103CCP	ACP103CCP	ACP103CCP
17	1	Casing removable left side	ACP102CCP	ACP102CCP	ACP102CCP
18	1	Casing removable right side	ACP004CCP	ACP004CCP	ACP004CCP
19	1	Casing front	-	-	-
20	1	*Casing back	ACP005CCP	ACP005CCP	ACP005CCP
21	1	Casing top	ACC000CTG	ACC000CTG	ACC000CTG
22	1	Terminal guard	ACC012PVL	ACC012PVL	ACC012PVL
23	1	Pressure vessel			

For burner parts refer to burner manual.  
\*Contact Firebird if required.

## TECHNICAL SPECIFICATION

<b>HEAT OUTPUT</b> kW	20	26	35
<b>CONNECTIONS</b>	-	-	-
Heating Flow	22 mm dia.	22 mm dia.	28 mm dia.
Heating Return	22 mm dia.	22 mm dia.	28 mm dia.
Mains Cold Feed (Copper)	15 mm dia.	15 mm dia.	15 mm dia.
Hot Water Delivery (Copper)	15 mm dia.	15 mm dia.	15 mm dia.
Drain Off Valve	½" BSP	½" BSP	½" BSP
Safety Pressure Valve Outlet (Copper)	15 mm dia.	15 mm dia.	15 mm dia.
Condensate Trap	22 mm dia. plastic	22 mm dia. plastic	22 mm dia. plastic
<b>CIRCULATING PUMP</b>	25/60	25/60	25/60
Domestic Hot Water Plate Heat Exchanger	25 plate	25 plate	25 plate
Integral Expansion Vessel Normal Capacity	12 litres	12 litres	12 litres
Expansion Vessel Pre-charge Pressure	1 bar	1 bar	1 bar
Low Pressure Water Switch?	✓	✓	✓
Filling Loop Included?	✓	✓	✓
<b>WATER CONTENT</b>	-	-	-
Boiler	24 litres	24 litres	24 litres
Primary Tank	20 litres	20 litres	20 litres
<b>D.H.W. GUIDE PERFORMANCE*</b>	-	-	-
in litres/min (120 litre draw-off at 40°C Δt.)	16	16	20
<b>FLUE (INDOOR BOILERS)</b>	-	-	-
Balanced Flue Assembly	125 (5") mm dia.	125 (5") mm dia.	125 (5") mm dia.
Max. Low Level Flue Length	1.5m	1.5m	1.5m
Max. High Level Balanced Flue Length	6m	6m	6m
<b>HEATING SYSTEM (SEALED)</b>	Fit in accordance with BS 7074 Part 1, BS 5449, OFTEC standards and all other relevant legislation.		
Max. Operating Pressure	2 bar	2 bar	2 bar
Max. System Pressure Cold	1.5 bar	1.5 bar	1.5 bar
Min. System Pressure Cold	0.5 bar	0.5 bar	0.5 bar
Preset Pressure Relief Valve	3 bar	3 bar	3 bar
<b>MAINS WATER SUPPLY PRESSURE</b>	Min. 3 bar - Max. 5 bar (for user comfort, we recommend pressure at tap to be between 2 and 3 bar). Limescale excess: When over 150/200 ppm, fit appropriate scale reducer/water softener.		
<b>WATER SIDE RESISTANCE</b>	<b>Flow Rate To Give A Nominal Output At 10K Differential</b>		
		<b>20kW</b>	<b>26kW</b>
		<b>35kW</b>	
	Flow Rate Measured	1642 kg/h	2135 kg/h
		2874 kg/h	
	Waterside Resistance	0.18 mbar	0.18 mbar
		0.18 mbar	0.18 mbar
	<b>Flow Rate To Give A Nominal Output At 20K Differential</b>	<b>20kW</b>	<b>26kW</b>
		<b>35kW</b>	
	Flow Rate Measured	870 kg/h	1131 kg/h
		1523 kg/h	
	Waterside Resistance	0.19 mbar	0.19 mbar
		0.19 mbar	0.19 mbar

\* where water demand exceeds this, a flow restrictor is recommended. This will ensure a water supply at an adequate temperature.

## 4 4.1 SLIMLINE COMBI - HOUSEHOLDER/END USER INFORMATION

Please consult with your installer regarding the operation of your boiler. This should include timer operation/room thermostat operation and any other additional operational features. The basic features of the control panel are outlined below.

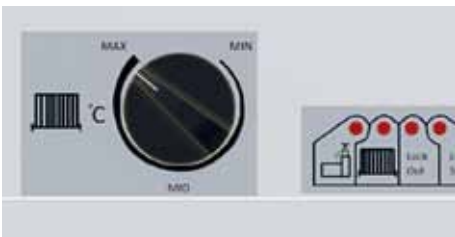

Maximum



Medium



Minimum

### BOILER THERMOSTAT/THERMISTOR FUNCTION

The control thermostat on the boiler allows the householder to vary temperature to central heating from a low of 60°C to 80°C, depending on the model. Thermostats have a tolerance of + 4°C.

In accordance with EU boiler standards, your boiler is also fitted with a safety high limit thermostat, fixed at 110°C. This system protects the boiler in the event of the control thermostat failing and keeps the boiler safe.

The safety high limit thermostat will shut the boiler off and will require the limit button to be pushed to restart the boiler. It is recommended to call a service engineer to establish the cause.

### BURNER LOCKOUT

The boiler is factory fitted with a burner control box lockout safety feature which operates automatically if a fault occurs in the burner operation. Should this occur, the light on the front of the burner will illuminate.

This could be caused by:

- A. An interruption in the fuel supply (eg. empty oil supply tank).
- B. An electrical supply fault.
- C. A fault with the burner or its safety control system.
- D. The failure of a burner component.
- E. Worn or dirty oil nozzle.
- F. Incorrect flue installation.

Before attempting to restart the boiler, the front panel and the burner cover should be removed and a visual check made for any obvious problems such as oil leaks, loose connections etc. This should be done by a service engineer.

Please note the following important points before commencing installation.

Installation should only be carried out by a competent, qualified engineer, familiar with the installation of the Firebird boilers referred to in this manual.

### WARNING

The manufacturer cannot accept responsibility for any damage to persons, animals or property due to error in installation or in the burner adjustment or due to improper or unreasonable use or non-observance of the technical instruction enclosed with the burner, or due to the intervention of unqualified personnel.

### POSITIONING THE BOILER

Compliance guide to part L now states that when installing a boiler on a new or existing system, the system should be cleaned, flushed and then protected with a suitable protection inhibitor.

Ensure that adequate clearance is available for making the water and flue connections.

The boiler is serviced from the front and a clearance of 750mm must be available at the front of the boiler.

No special hearth is required as the boiler is fully insulated, but the floor must be level and capable of supporting the weight of the boiler and its water content.

Sound levels must also be a consideration. Whilst Firebird condensing oil boilers are one of the quietest boilers on the market, some householders are particularly sensitive.

**A suitable corrosion inhibitor must be added to the heating system.**

### UNDERFLOOR HEATING

The boiler should not be directly connected to underfloor heating, as a minimum return temperature of 37° is required (it can be used with underfloor heating with adequate temperature controls to ensure return values are as stated above).

### PLASTIC PIPING

The boiler thermostat control and safety system is not designed, and must not be relied on, to protect plastic pipe from overheating. Plastic pipe must never be connected directly to the boiler and there must be at least 1 meter of copper pipe between the boiler and the first plastic connection. If you choose to use plastic pipe anywhere on your heating circuits, please consult the plastic pipe manufacturer for their instruction on how to ensure their product never overheats. Our boiler control and safety high limit thermostats are not designed to fulfil this function. **Firebird accepts no responsibility for failure of plastic piping and fittings for whatever reason.**

### PRESSURISED HEATING SYSTEM

The maximum operating working pressure is 2 bar when the system is at full operating temperature.

### MAGNETIC FILTRATION

It is recommended at the time of installation of this boiler, to install a permanent effective magnetic filter on the return pipework after the last radiator on the central heating system. This will maintain maximum operational efficiency and protect the boiler from the damaging, long-term effects of "magnetite" (black iron sludge). It is essential that the filter

is sized similar to the return pipework. The magnetic filter must be installed in accordance with the manufacturer's instructions and serviced annually.

### HARD WATER - LIMESCALE

On initial fill, where it is suspected that there is a high concentration of scale products, a suitable inhibitor must be used to protect the boiler and system. Check with local water authorities if in doubt (max. 200 ppm).

### PIPEWORK

Do not obstruct flue fitting with Pipework. Connect pipework as shown below.

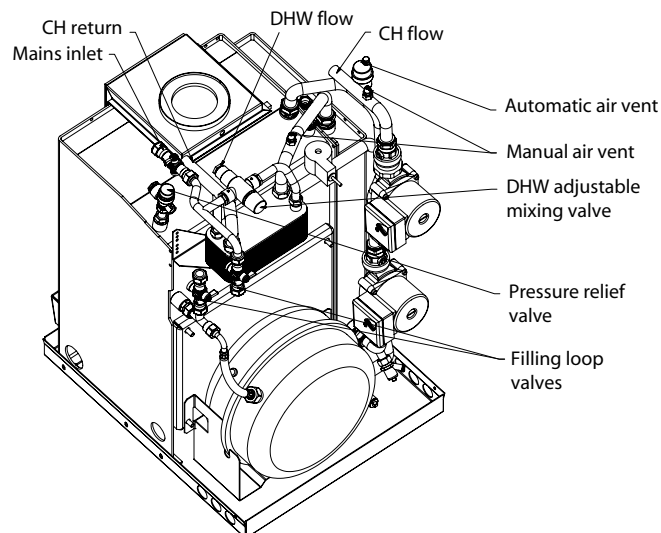

### FILLING THE SYSTEM

The unit comes with a factory fitted expansion vessel. Should the total water volume of the system exceed the expansion provided, a second vessel should be added (see below table).

#### Expansion Vessel and System Requirements

Safety Valve Setting	3 bar		
Initial System Pressure	0.5 bar	1.0 bar	1.5 bar
Total Water Content of System	Total Vessel Volume **		
	Litres	Litres	Litres
25	2.1	2.7	3.9
50	4.2	5.4	7.8
75	6.3	8.2	11.7
100	8.3	10.9	15.6
125	10.4	13.6	19.5
150	12.5	16.3	23.4
175	14.7	19.1	27.2
200	16.7	21.8	31.2
225	18.7	24.5	35.1
250	20.8	27.2	39.0

FOR FURTHER INFORMATION, CONSULT APPROPRIATE TRAINING MANUALS, BS 7074 PART 1, EN 12828:2003 AND ANY OTHER RELEVANT STANDARDS & REGULATIONS.

\*\* When calculating the size of any additional expansion vessel, remember to deduct the boiler expansion vessel volume of 12 litres from the calculated total system vessel volume required, as given in the above table.

## 4 4.2 SLIMLINE COMBI - INSTALLER GUIDELINES

### FILLING LOOP

Connect the filling loop. Open both valves. Do not allow the unit to exceed 1 bar while filling and a maximum of 2 bar when the radiators are at full operating temperature. The automatic air vent will allow air to dispel from the boiler. To remove air from the storage tank, the manual air vent must be operated. When the system is full, turn off both valves and disconnect the filling loop.

### CONNECTING OIL SUPPLY

Using the flexible hose provided, connect the burner to the incoming oil line which must have a remote acting fire valve. **The flexible hose must be contained within the appliance casing.**

### WIRING

#### Electrical Supply

**The boiler and controls require a 230V 50Hz mains electric supply protected with a 5A fuse.**

**This appliance must be earthed.**

A qualified electrician must carry out all electric wiring in accordance with current ETCI / IET Regulations and any local regulations which may apply.

The boiler must have a permanent power supply to enable overrun and frost protection. The hot water and central heating should be timed separately.

#### THERMOSTAT TEMPERATURE CONTROL

Boiler Central Heating Control:	60°C - 80°C
Boiler Safety Limit:	110°C
Tank (DHW) - Fixed:	78°C
Early Alert - Fixed:	87°C
Over-run - Fixed:	93°C

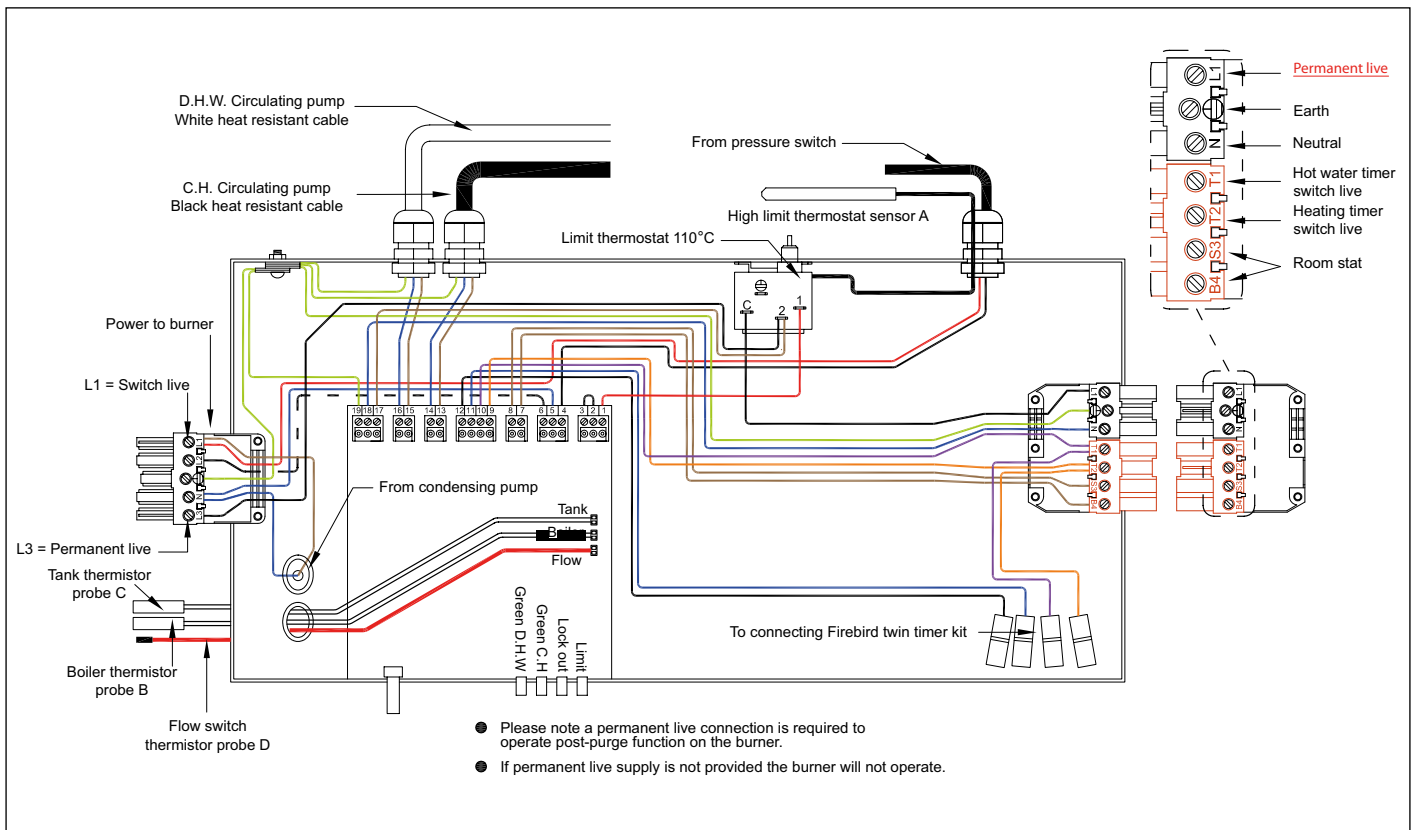

## FLAP VALVE INSTALLATION

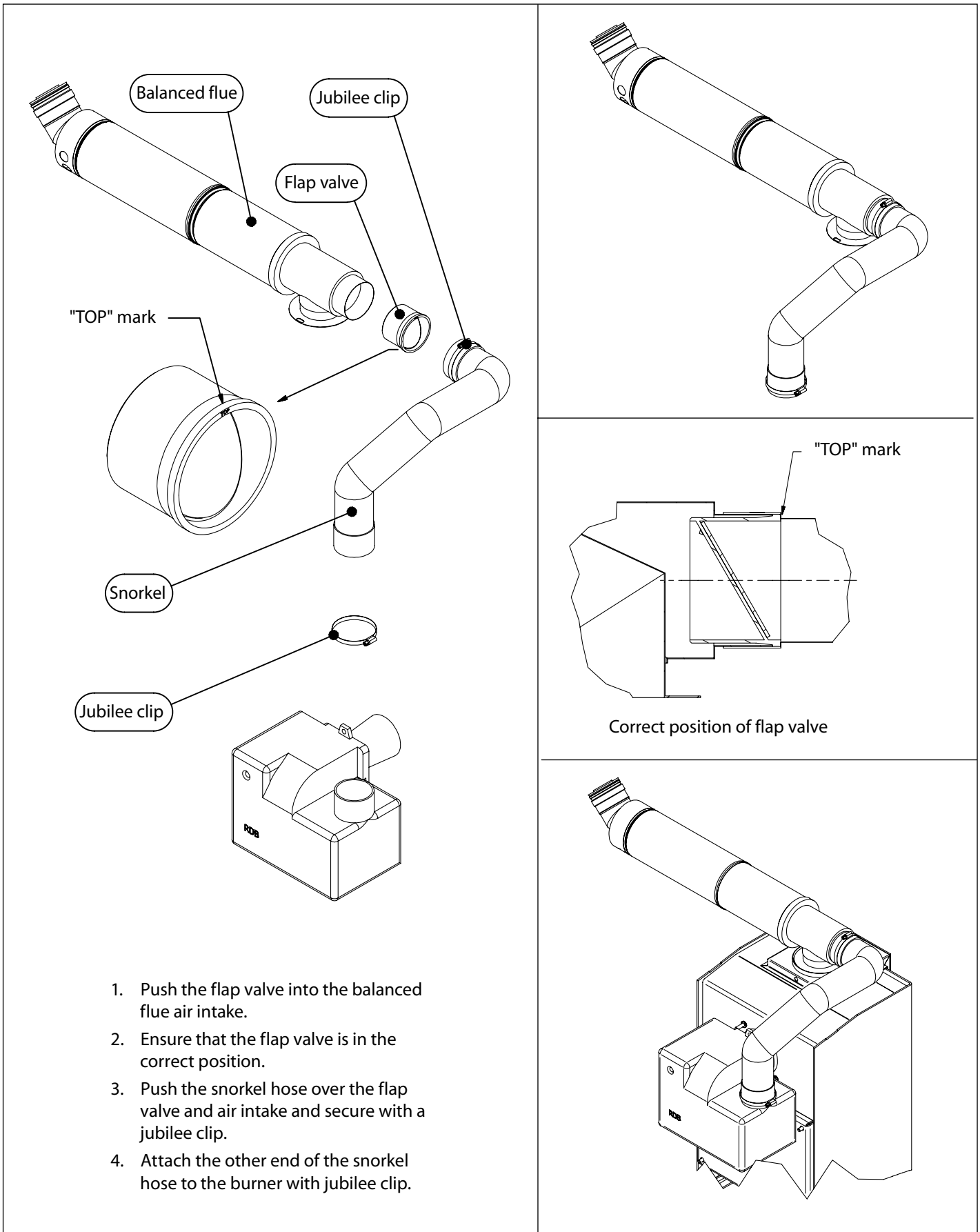

# 4 4.3 SLIMLINE COMBI - TECHNICAL DETAILS

## TECHNICAL DETAILS

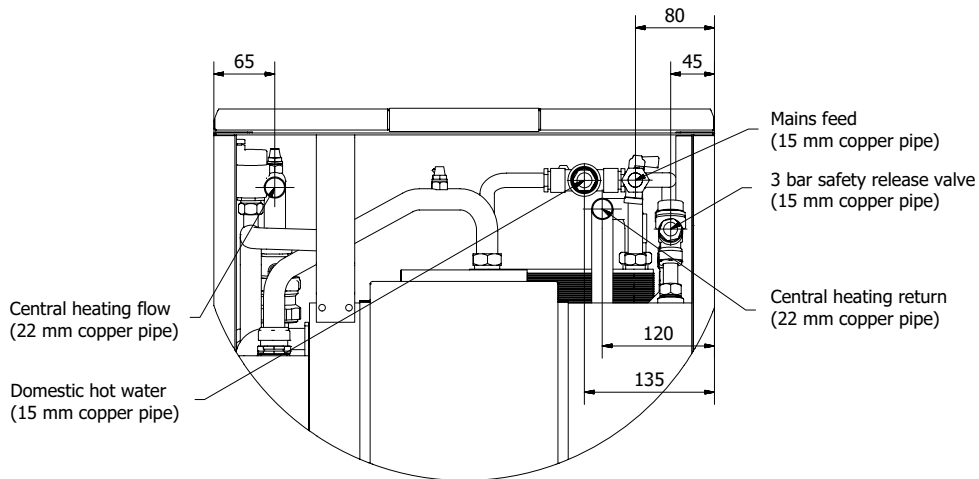
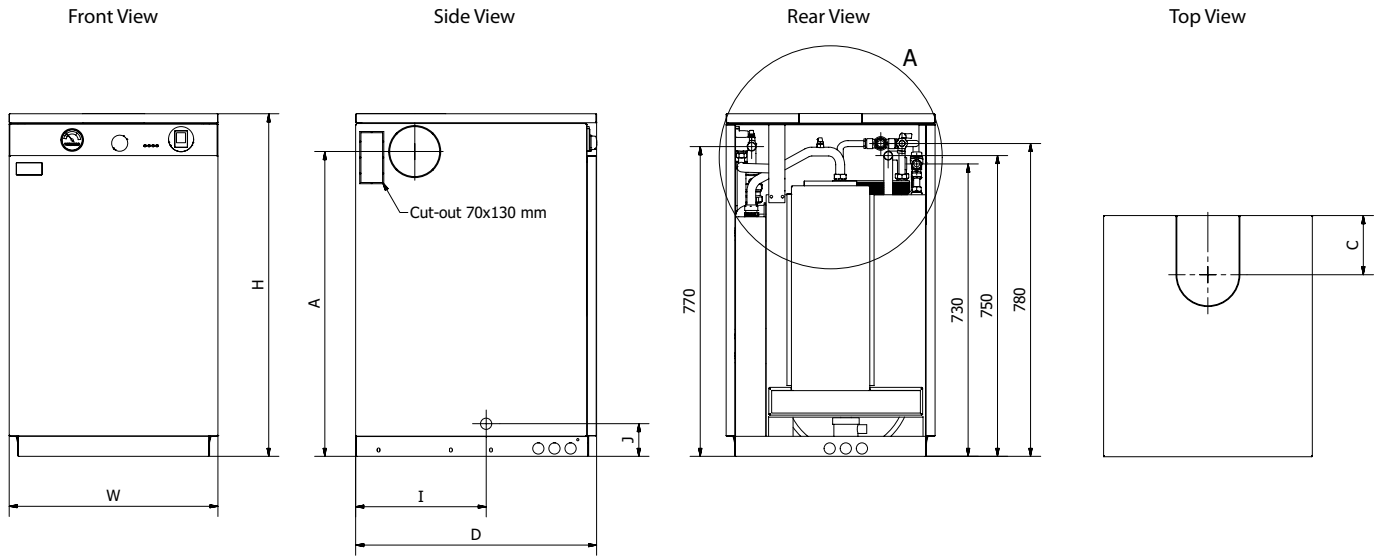

Model - Slimline Combi (output)	Weight kg	Dimensions (mm)						
		H	W	D	A	C	I	J
20kW	165	855	520	600	760	147	325	80
26kW	168	855	520	600	760	147	325	80
35kW	172	855	520	600	760	147	325	80

## SLIMLINE COMBI

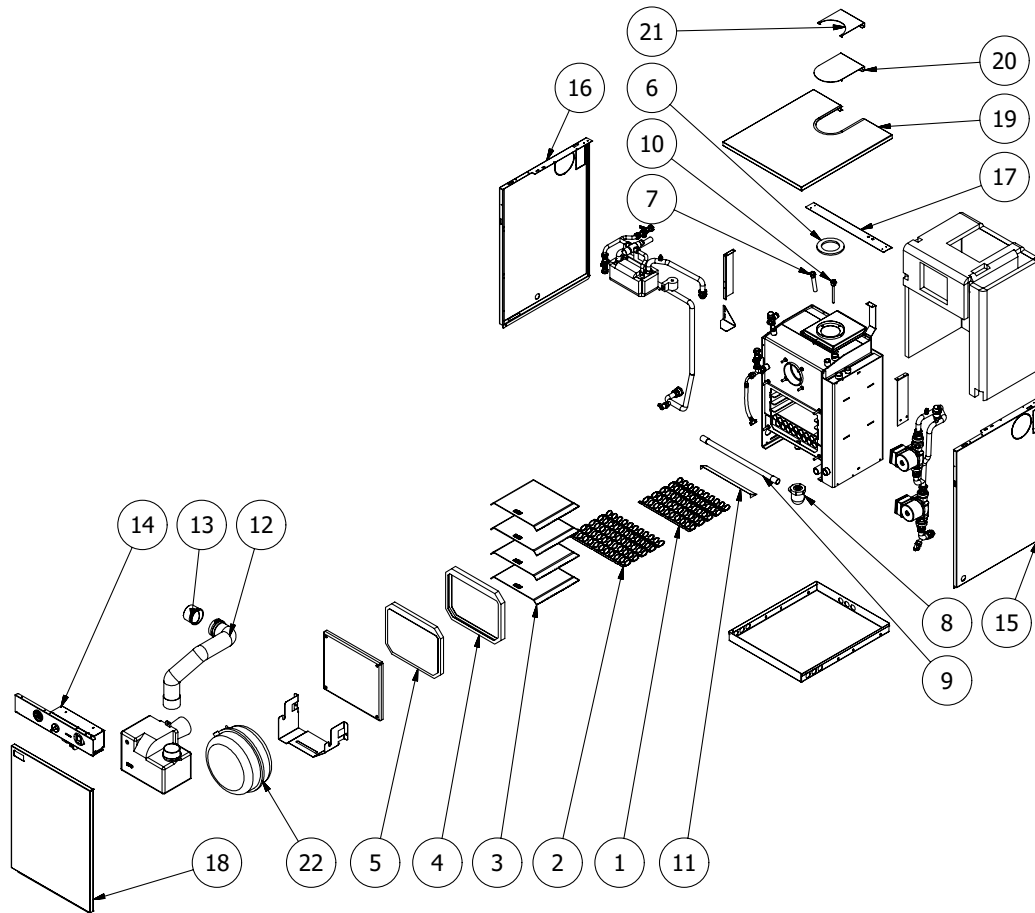

No.	Qty	Description	20kW	26kW	35kW
1	4	Tube baffle	BA110907	BA110907	BA110907
2	5	Tube baffle single	BA110908	BA110908	BA110908
3	4	Smoke baffle	BA212022	BA212028	BA212122
4	1	Door seal	ACC000DDS	ACC000DDS	ACC000DDS
5	1	Door duroboard	ACC000FRG	ACC000FRG	ACC000FRG
6	1	Flue gasket	ACC003PKT	ACC003PKT	ACC003PKT
7	1	Stat pocket	ACC000TRP	ACC000TRP	ACC000TRP
8	1	Condensate trap	ACC000FLX	ACC000FLX	ACC000FLX
9	1	Condensate hose	ACC001PKT	ACC001PKT	ACC001PKT
10	1	Stat pocket	-	-	-
11	1	*Heat deflector	ACC000SSH	ACC000SSH	ACC000SSH
12	1	Air hose	ACC000FLP	ACC000FLP	ACC000FLP
13	1	Flap valve	ACP001CSL	ACP001CSL	ACP001CSL
14	1	Control panel	ACP002CSL	ACP002CSL	ACP002CSL
15	1	Casing right side	ACP003CSL	ACP003CSL	ACP003CSL
16	1	Casing left side	-	-	-
17	1	*Back support	ACP004CSL	ACP004CSL	ACP004CSL
18	1	Casing front	ACP005CSL	ACP005CSL	ACP005CSL
19	1	Casing top	-	-	-
20	1	*Top flue blank	-	-	-
21	1	*Top half moon blank	-	-	-
22	1	Pressure vessel	ACC012PVL	ACC012PVL	ACC012PVL

For burner parts refer to burner manual.

\*Contact Firebird if required.

## TECHNICAL SPECIFICATION

HEAT OUTPUT kW	20	26	35	
<b>CONNECTIONS</b>	-	-	-	
Heating Flow	22 mm dia.	22 mm dia.	22 mm dia.	
Heating Return	22 mm dia.	22 mm dia.	22 mm dia.	
Mains Cold Feed (Copper)	15 mm dia.	15 mm dia.	15 mm dia.	
Hot Water Delivery (Copper)	15 mm dia.	15 mm dia.	15 mm dia.	
Drain Off Valve	½" BSP	½" BSP	½" BSP	
Safety Pressure Valve Outlet (Copper)	15 mm dia.	15 mm dia.	15 mm dia.	
Condensate Trap	22 mm dia. plastic	22 mm dia. plastic	22 mm dia. plastic	
<b>CIRCULATING PUMP</b>	25/60	25/60	25/60	
Domestic Hot Water Plate Heat Exchanger	25 plate	25 plate	25 plate	
Integral Expansion Vessel Normal Capacity	12 litres	12 litres	12 litres	
Expansion Vessel Pre-charge Pressure	1 bar	1 bar	1 bar	
Low Pressure Water Switch?	✓	✓	✓	
Filling Loop Included?	✓	✓	✓	
<b>WATER CONTENT</b>	-	-	-	
Boiler	24 litres	24 litres	24 litres	
Primary Tank	11 litres	11 litres	11 litres	
<b>D.H.W. GUIDE PERFORMANCE*</b>	-	-	-	
in litres/min (120 litre draw-off at 35°C Δt.)	14	16	16	
<b>FLUE (INDOOR BOILERS)</b>	-	-	-	
Balanced Flue Assembly	125 (5") mm dia.	125 (5") mm dia.	125 (5") mm dia.	
Max. Low Level Flue Length	1.5m	1.5m	1.5m	
Max. High Level Balanced Flue Length	6m	6m	6m	
<b>HEATING SYSTEM (SEALED)</b>	Fit in accordance with BS 7074 Part 1, BS 5449, OFTEC standards and all other relevant legislation.			
Max. Operating Pressure	2 bar	2 bar	2 bar	
Max. System Pressure Cold	1.5 bar	1.5 bar	1.5 bar	
Min. System Pressure Cold	0.5 bar	0.5 bar	0.5 bar	
Preset Pressure Relief Valve	3 bar	3 bar	3 bar	
<b>MAINS WATER SUPPLY PRESSURE</b>	Min. 3 bar - Max. 5 bar (for user comfort, we recommend pressure at tap to be between 2 and 3 bar). Limescale excess: When over 150/200 ppm, fit appropriate scale reducer/water softener.			
<b>WATER SIDE RESISTANCE</b>	<b>Flow Rate To Give A Nominal Output At 10K Differential</b>	<b>20kW</b>	<b>26kW</b>	<b>35kW</b>
	Flow Rate Measured	1642 kg/h	2135 kg/h	2874 kg/h
	Waterside Resistance	0.18 mbar	0.18 mbar	0.18 mbar
	<b>Flow Rate To Give A Nominal Output At 20K Differential</b>	<b>20kW</b>	<b>26kW</b>	<b>35kW</b>
	Flow Rate Measured	870 kg/h	1131 kg/h	1523 kg/h
	Waterside Resistance	0.19 mbar	0.19 mbar	0.19 mbar

\* where water demand exceeds this, a flow restrictor is recommended. This will ensure a water supply at an adequate temperature.

### COMMISSIONING

- ◆ It is the responsibility of the installer to ensure that the boiler is properly commissioned when first used.
- ◆ The boiler should be commissioned by an OFTEC registered, or competent, qualified engineer, familiar with Firebird products.
- ◆ The installation certificate and the commissioning certificate within the boiler passport should be completed and posted to Firebird within 28 days of installation (this can also be done online on the Firebird website). A copy should be retained by the commissioning engineer.
- ◆ The system should be checked thoroughly.

### CHECKLIST FOR INSTALLING AND COMMISSIONING A FIREBIRD BOILER

#### Pre-installation check:

- ◆ Is the following documentation included with the boiler, Installation Manual, Boiler Passport, Burner Book?
- ◆ Is the base on which the boiler is to be installed solid?
- ◆ Allow sufficient room for future servicing of the boiler.

#### Where does the flue terminate:

- ◆ Make sure there is no window, door or fence within 1 metre of the flue-terminal.
- ◆ If the flue terminates in a corner or into an allyway, re-circulation of the combustion gases in the air intake could occur. A plume dispersal may be required or an alternative flue arrangement might be available. Contact the Firebird technical department for advise.
- ◆ The appropriate class 1 flue must be used with a conventional flue installation. Contact Firebird if unsure.

#### Power supply:

- ◆ Is a timed, permanent, power supply available, via a fused spur with a 230V 50Hz mains electrical supply and a 5A fuse?

#### Oil supply:

- ◆ The burner is set for 28 Second Class C fuel.
- ◆ A 15 micron oil filter should be placed in line with an isolating valve prior to entry to the burner.
- ◆ There must be a remote sensing fire valve.
- ◆ Verify that the oil tank has been installed correctly as per building standards.

## 5 COMMISSIONING & BURNER SETTINGS

### Boiler check:

- ◆ Baffles should be checked as they may have been disturbed during transport.
- ◆ Check that the condensate trap is fitted securely, primed with water and piped out into a suitable drain. It is easier to check the trap when the boiler door is removed.
- ◆ The boiler door should be refitted, complete with graphite seal and then tightened.

### Flue check:

- ◆ The flue must be fitted correctly, with a fall back to the boiler. Note: internal fall of 2.5° within the flue.
- ◆ For concentric balanced flue:
  - the cone supplied should be inserted in to the end of the flue;
  - the wall plate should be fitted with an opening for air under the flue;
  - check that the flue guard is fitted.
- ◆ When installing a Combipac HE the 90° bend should be fitted pointing up.

### Boiler set-up:

- ◆ For burner set-up, see next page.
- ◆ Set the air to what is required for the nozzle size +. 5 on the dial - example: the factory setting for a Firebird 26kW has a Danfoss .65 80° ES nozzle with a pump pressure of 9 bar and air at 2.5. The final air setting to suit the boiler set up will be determined by using a flue gas analyser.
- ◆ Turn on the oil supply and switch on power to the boiler.
- ◆ Check all connections for possible leaks.
- ◆ Check thermostat operation and set desired temperature on completion.
- ◆ Use a smoke gun to check clean combustion.

### Flue gas analysis and fine tuning of burner:

- ◆ Ensure flue gas is over 50°C when setting CO<sub>2</sub>.
- ◆ Allow the boiler to run for a period of time before fine tuning to the Firebird settings.
- ◆ Fine tuning of the burner should take place once the recommended oil pressure value has been obtained. Burner air should then be adjusted to achieve the desired CO<sub>2</sub> setting.
- ◆ Print off a copy of the flue analysis and attach to the boiler passport.
- ◆ Make sure the flue gas analysis plug is replaced correctly into the flue when finished the flue analysis.

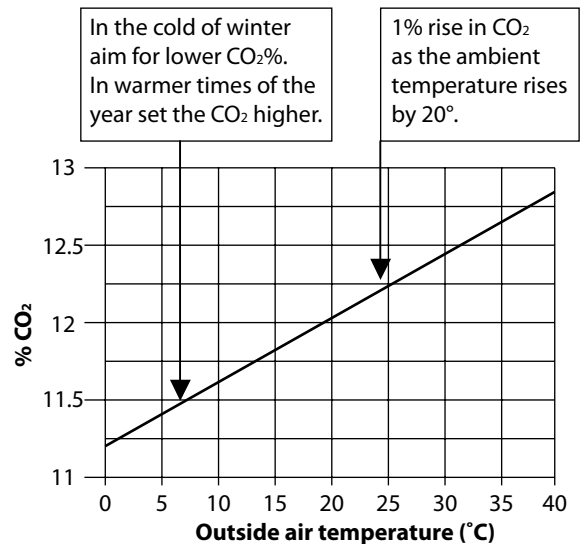

### HANDING OVER

#### *The householder should receive:*

- A clear and concise demonstration of the boiler operation and any system controls.
- This manual, the burner manufacturer's manual and any other instructions.
- OFTEC forms CD10 and CD11.
- The boiler passport.

#### *The householder should be advised to:*

- Service the boiler annually and to ensure that the service records in the boiler passport are completed.
- Read the terms and conditions of warranty.
- Keep all boiler documentation in a safe place.

**A commissioning record should be completed and a copy retained by the Engineer. This can be found in the Boiler Passport.**

## 5 COMMISSIONING & BURNER SETTINGS

*The burner nozzle, pump pressure and air setting may have to be changed from the factory setting to suit site conditions.*

### KEROSENE SETTINGS FOR FIREBIRD BOILER RANGE USING RDB 2.2 BURNERS

Variations in nozzle throughput, flue type & draught, oil viscosity etc. may give results differing from the below laboratory performance figures. These settings were carried out using a conventional flue.

Model	Burner	Output		Blast Tube	Nozzle			Pump Pressure	Air Shutter	Comb Head	Air Box	Avg. Fg. °C	CO <sub>2</sub>	Smoke Bacharach	Restrictor Disc	Deflector Plate
		kW.	BTU		Size	Angle	Type									
20kW	RDB 2.2	18	59K	LD2X	0.5	80°	ES	8.5 bar	1.5	-	1	70	11.5%	0-1	C	A11
		20	68K	LD2X	0.6	80°	ES	8 bar	2.8	-	1	75	11.5%	0-1	C	A11
26kW	RDB 2.2	20	68K	T3	0.6	80°	ES	9 bar	1.8	-	1	70	11.5%	0-1	-	STD
		23	79K	T3	0.65	80°	ES	9 bar	2.5	-	1	80	11.5%	0-1	-	STD
		26	89K	T3	0.75	80°	ES	9 bar	4.0	-	1	85	11.5%	0-1	-	STD
35kW	RDB 2.2	26	89K	T3	0.75	80°	ES	9 bar	4.0	-	1	80	11.5%	0-1	-	STD
		31	104K	T3	0.85	80°	ES	9 bar	5.0	-	1	90	11.5%	0-1	-	STD
		35	120K	T3	1.00	80°	ES	8.2 bar	6.5	-	1	95	11.5%	0-1	-	STD

The shaded line represents factory settings. These settings override those in the burner manual.

The above performance figures are based on ideal laboratory test conditions. The air shutter settings above may need to be revised to take into consideration the difference in resistances between conventional and balanced flue installations, air temperature and nozzle tolerance. Use flue gas analyzer to achieve optimum results. Danfoss ES nozzles are a Kerosene nozzle and have a tolerance of +- 5%. Danfoss S + H nozzles are a Diesel nozzle and have a tolerance of +- 15% when used with Kerosene.

### SETTING THE BURNER

1. Establish the type of fuel in the oil tank.
2. Check that the nozzle type, pump pressure and air settings are as per the manual for the output required.
3. Set the thermostat to the minimum temperature and let the boiler run until it cuts out at 60°C.
4. The boiler must be at 60°C or higher before any adjustments or analysing is carried out.  
By doing this, you are also ensuring the thermostat is working.
5. Increase the thermostat setting to refire the burner.
6. Wait for the CO<sub>2</sub> to stabilise.
7. Adjust the air and pump pressure to achieve a stable CO<sub>2</sub> in the region of 11.5% (refer to graph under Commissioning & Burner Settings).
8. The fuel option on the flue gas analyser should be set to a light oil.

**Annual servicing must be carried out by an OFTEC registered or a competent, qualified engineer, familiar with Firebird products.**

Do not commence service until both the electrical and oil supply to the boiler have been safely isolated.

### THE OIL TANK

Check for oil leaks. Draw off any accumulated water and sludge from the tank by opening the drain valve. Turn off the oil supply and remove the filter bowl, then wash the element clean with Kerosene. Fit a new element if required.

### THE BOILER

Remove combustion access door for access to baffles and to clean heat exchanger.

#### **Cleaning a Firebird condensing boiler:**

1. Remove all baffles, including the tubular baffles in the condensing section and clean them.
2. Remove the condensate trap and clean it, place a tray under the connection for the trap. Vacuum out any loose debris from the chamber.
3. Clean the inside of the boiler with a vacuum cleaner.
4. Refit all the baffles and the condensate trap securely.
5. System pressure should not exceed 2 bar at full operating temperature. The expansion vessel should be checked during the annual service to ensure that it is operating correctly.

Check insulation sealing and the silver foil lining in combustion access door - replace if necessary. Check graphite seal and replace if necessary. When refitting this door be careful not to damage the foil and insulation by over tightening.

Check that the condensate trap is secure in position, clean and free of combustion debris. Ensure that the condensate drain is free and not blocked.

Expansion vessel pre-charge pressure should be checked annually and set according to the system design.

### THE BURNER

**Ensure correct specification replacement nozzle is used. See page 30 for more information on the burner**

1. Check all oil filters and replace as necessary.
2. Remove burner, clean blast tube and ensure that airways are clear.
3. Ensure electrodes are clean, dry, not broken and are set as per burner specifications.
4. Clean fan and photocell.
5. **Once again check flexible oil lines and connections for damage or leaks, replace as necessary. Replace flexible oil lines every 2 years.**

#### **Combustion Check**

1. Carry out a combustion analysis.
2. Follow the steps as set out in the burner set-up section.
3. Check safety operation, pull out the photo cell, cover and make sure the burner locks out.
4. Check the thermostat operation.
5. Allow the boiler to operate for at least two full "on/off" cycles.

**Ensure service is recorded in boiler passport.**

## 7 TERMS & CONDITIONS OF WARRANTY

Firebird products are designed and manufactured to give many years of trouble free service.

The terms laid down in the warranty must be adhered to

- ◆ Firebird provides a comprehensive, conditional warranty of 5 years on the boiler shell and 2 years on all other parts from date of installation, provided installation has occurred within 12 months from date of purchase.
- ◆ The 5 year boiler shell warranty consists of parts and labour for the first 3 years and parts only for years 4 and 5.
- ◆ The warranty will only apply if the boiler is commissioned by an OFTEC registered or competent, qualified engineer and is serviced annually thereafter.
- ◆ Please ensure that the commissioning certificate within the Boiler Passport is fully completed by an OFTEC registered or competent, qualified engineer and is returned to Firebird within 28 days of complete installation and commissioning. The Boiler Passport is included with every boiler and can also be completed online at the following link:  
<http://www.firebird.ie/index.php/boiler-passport.html>.
- ◆ Correct commissioning will ensure that your boiler is set to operate at its maximum fuel efficiency.
- ◆ Consumable components, the nozzles and the oil hose are excluded.

### TERMS & CONDITIONS OF WARRANTY

1. Warranty implies that the product shall be free from defective parts or workmanship for a period of warranty cover, which begins from the date of installation.
2. All claims under the warranty programme must be within the time limits stated on the left.
3. Installation and commissioning of the product must be in accordance with (a) instruction/technical manuals (b) all relevant standards and codes of practice.
4. An OFTEC registered or competent, qualified engineer, using the correct installation and test equipment must carry out installation and commissioning.
5. This warranty does not cover special, incidental or consequential damages, injury to persons or property, or any other consequential loss.
6. Servicing of the boiler is to be carried out annually to maintain the manufacturer's warranty.
7. Firebird accepts no liability in respect of any defect arising from incorrect installation, negligence, fair wear and tear, misuse, alteration or repair by unqualified persons.
8. Firebird will not accept any liability in respect of any defect occurring to the product due to limescale build-up and or low return water temperature.
9. The warranty programme extends to reasonable labour costs EXCEPT in the case of a 5 year warranty period whereby any valid claim made after 3 years will not include labour costs.
10. Firebird's prior authorisation must be obtained before examination or repair of the product takes place.
11. Firebird will examine all claims made under the warranty programme and for any claims that are deemed invalid, the costs incurred will be borne by the owner.
12. The warranty programme only applies where the product was used for normal domestic heating purposes.
13. Any defective part removed under any or all of the warranty programmes MUST be returned to Firebird.
14. If this appliance is installed in a pressurised system, failure to correctly size the expansion vessel may damage the boiler and invalidate the warranty
15. A full set of warranty conditions and terms can be found on the Firebird website.

*STATUTORY RIGHTS OF THE OWNER ARE NOT  
AFFECTED BY THIS WARRANTY*

**ErP A Rated**

Model Identifier	Energy efficiency class		Rated heat output	Seasonal Efficiency Base Model		Annual energy consumption		Sound power level
			kW	%		GJ		dB
<b>Enviromax</b>	Space Heating	Water Heating		Space Heating	Water Heating	Space Heating	Water Heating	
<b>COMBI HE</b>								
<b>20kW</b>	A	B	20	93	75	62	21	46
<b>26kW</b>	A	B	26	93	74	80	21	47
<b>35kW</b>	A	B	35	93	70	109	23	52
<b>COMBIPAC HE</b>								
<b>20kW</b>	A	B	26	93	75	62	21	N/A
<b>26kW</b>	A	B	35	93	74	80	21	N/A
<b>36kW</b>	A	B	44	93	70	109	23	N/A
<b>SLIMLINE COMBI</b>								
<b>20kW</b>	A	B	20	93	75	50	19	46
<b>26kW</b>	A	B	26	93	76	71	19	47





# FIREBIRD

## HEATING SOLUTIONS

For further information on Firebird products please contact:

**Firebird Heating Solutions Ltd.**

Údarás Industrial Estate, Baile Mhic Íre, Co. Cork, P12 HK51, Ireland.

t: +353 (0)26 45253 f: +353 (0)26 45309

e: [info@firebird.ie](mailto:info@firebird.ie) web: [www.firebird.ie](http://www.firebird.ie)

**Firebird Heating Solutions Ltd.**

Shean, Forkhill, Newry, BT35 9SY.

t: +44 (0)28 3088 8330 f: +44 (0)28 3088 9096

e: [firebirdproducts@hotmail.co.uk](mailto:firebirdproducts@hotmail.co.uk) web: [www.firebird.ie](http://www.firebird.ie)

**Firebird Products Ltd.**

Phoenix House, Eastern Wood Road,  
Plympton, Devon, PL7 5ET, United Kingdom.

t: +44 (0)1752 691177 f: +44 (0)1752 691131

e: [sales@firebird.uk.com](mailto:sales@firebird.uk.com) web: [www.firebird.uk.com](http://www.firebird.uk.com)

© Copyright applies to all FIREBIRD products. Our policy is one of continual development and we therefore reserve the right to change without prior notice the specification of our products at any time and be without obligation to make similar changes in products previously produced.