

100%  
IRISH

**FIREBIRD**



**HEATING SOLUTIONS**

# CASCADING MANAGEMENT CONTROLLER MANUAL





---

# INDEX

Page

1.	Controller Function .....	4
2.	Important Safety Notes .....	4
3.	Weather Compensation .....	4
4.	Wiring Schematic .....	5
5.	Quick Setup Guide .....	6
	5.1 First Time Power Up .....	6
	5.2 Example 4 Boiler Set Up .....	7
6.	Fault Finding .....	8
	6.1 Relay and Sensor Test .....	8
	6.2 Display Outside Temperature .....	9
	6.3 Reset to Factory Setting .....	10
	6.4 Header Temp Adjustment .....	11
	6.5 Turn off Weather Compensation .....	12
7.	Time Programming .....	13
8.	Warranty .....	14

---

## 1. CONTROLLER FUNCTION

The function of the controller is to regulate the supply of heated water to the Low Loss Header (LLH) and the Domestic Hot Water Tank (DHW) only. The controller uses sensors to determine how much heat is required by the LLH tank and the DHW tank so it can turn on the minimum number of boilers for the minimum amount of time to facilitate the demand.

This control unit is for use with the Firebird LLH and up to 4 boilers of the same kW output. It must have a sensor fitted in the LLH tank and connected to terminals ① 8+7 (see diagram on next page). If the DHW function is required, a sensor must be fitted to the DHW tank and terminals ① 6+7 on the controller, 7 is a common connection. For the weather compensation function, a sensor must be fitted under a North facing eave/soffit and to terminals ① 9+10 on the controller.

Each boiler working from this controller must be fitted with a thermostat and the live output from the controller must be wired through this thermostat.

This unit has many more functions than the basic ones outlined in this manual, for further information refer to the E8.4401 System Manager Operating Instructions manual supplied with this controller.

## 2. IMPORTANT SAFETY NOTES

All current relevant regulations and codes of practice must be adhered to and the installation must conform to building regulations at all times.

Important: all wiring needs to be carried out by a qualified, competent electrician.

All boilers, the LLH and the controller cabinet must be earthed.

## 3. WEATHER COMPENSATION

The weather compensation facility in this controller uses heat slopes, algorithms, an outside temperature sensor and the heat demand for the envelope of the building to determine the optimum temperature the building needs to achieve the correct temperature within the building.

# 4. WIRING SCHEMATIC

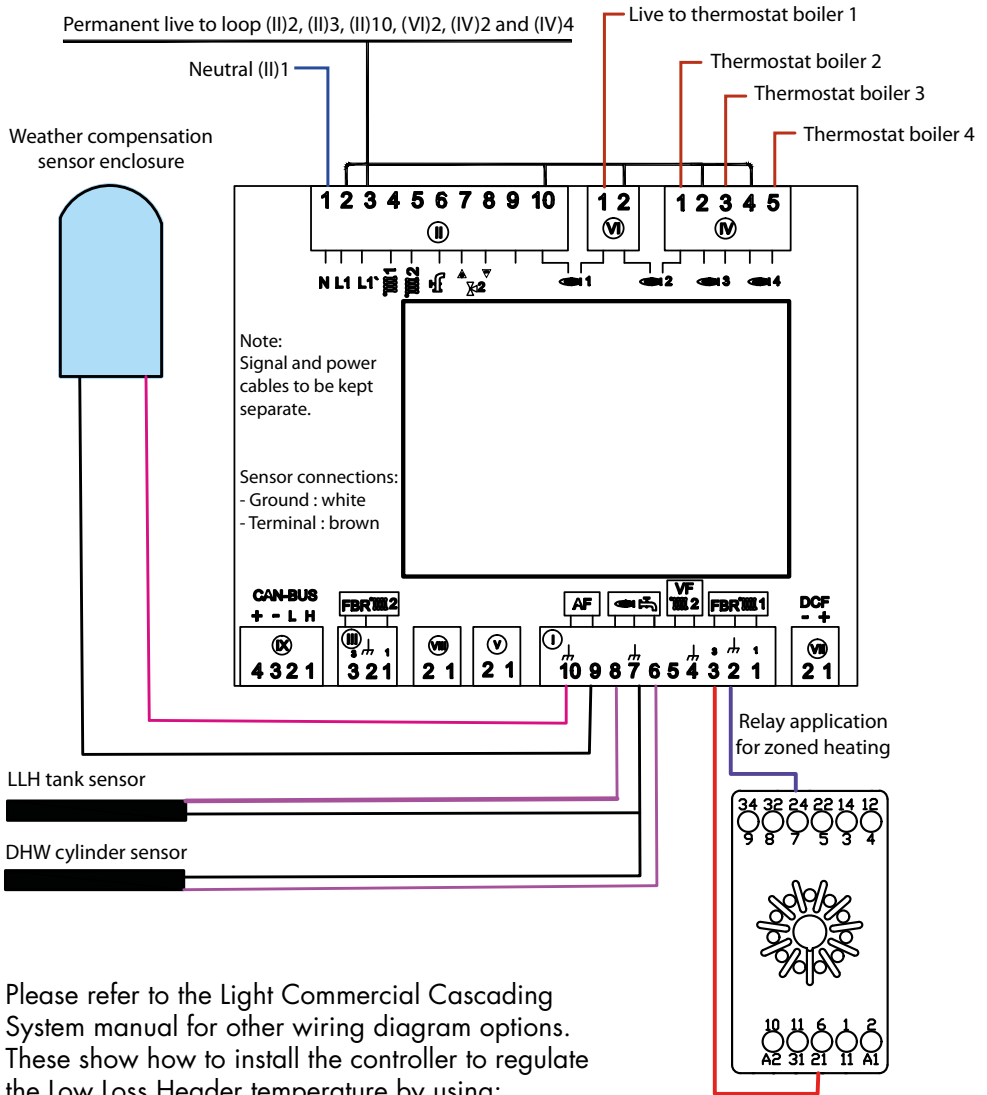

Please refer to the Light Commercial Cascading System manual for other wiring diagram options. These show how to install the controller to regulate the Low Loss Header temperature by using:

- (1) Its own internal clock.
- (2) Constant on.
- (3) Remote switching using a call from zones trough relays.
- (4) How to use different wiring schematics which are unique to the different Firebird boilers in our range.

## 5. QUICK SETUP GUIDE

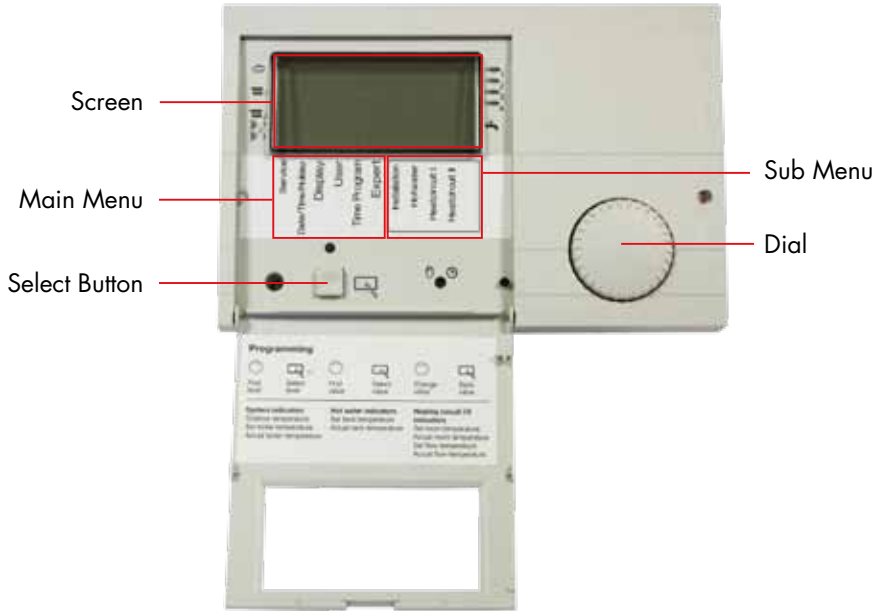

1. Open box, remove contents and check controller for any damage.
2. Remove the English version of the navigation notes sticker and apply to the door lid and under the screen as shown above.
3. Fit the controller into the control cabinet and attach all the relevant wiring.

### 5.1 FIRST TIME POWER UP

1. While holding the **"Select"** button switch on the power to the unit, **"EEPROM"** will appear on the screen.
2. Release the **"Select"** button and **"INSTALLATION"** will appear after approx. 10 seconds.
3. Press the **"Select"** button, this will take you to the language menu, turn the dial until choice language appears, then press **"Select"**, **"TIME"** then flashes.
4. Set the minutes using the dial, press **"Select"**.
5. Set the hour using the dial, press **"Select"**.
6. Set the year using the dial, press **"Select"**.
7. Set the month using the dial, press **"Select"**.
8. Set the day using the dial, press **"Select"**.

---

## 5.2 EXAMPLE 4 BOILER SET UP

Note: all boilers must be the same output.

1. Once the previous steps have been followed, **"HC FUNCTION 1"** appears on the screen (setting = 00) press **"Select"**.
2. **"HC FUNCTION 2"** appears on the screen (setting = 00) press **"Select"**.
3. **"CAP / MODULE"** appears on the screen, press **"Select"**.
4. **"Boiler 1 01"** appears on the screen, press **"Select"**.
5. **"CODE NO."** appears, press **"Select"** 5 times (code is 0000) (press 4 times to enter code and 1 to return).
6. **"BOILER 1 01"** appears again, press **"Select"**, turn the dial to select kW output of boiler 1, press **"Select"**.
7. Turn the dial until **"BOILER 2 01"** appears on the screen, press **"Select"**, turn the dial to select kW output of boiler 2, press **"Select"** (if you are using only 2 boilers, skip ahead to **"Return"**).
8. Turn the dial until **"BOILER 3 01"** appears on the screen, press **"Select"**, turn the dial to select kW output of boiler 3, press **"Select"** (if you are using only 3 boilers, skip ahead to **"Return"**).
9. Turn the dial until **"BOILER 4 01"** appears on the screen, press **"Select"**, turn the dial to select kW output of boiler 4, press **"Select"** and press **"Return"**.

If more than 4 boilers are required, a second module is needed.

10. Turn the dial until **"RETURN"** appears, press **"Select"**.
11. **"BUS ID 1"** appears, (setting = 00) turn the dial, **"CODE NO."** appears, press **"Select"** 5 times (0000), turn the dial until 01 appears then press **"Select"**.
12. **"BUS ID 2"** appears, press **"Select"**.
13. **"5K SENSORS"** appears (setting = 00), press **"Select"**.
14. **"INSTALLATION"** appears.
15. Close the door lid, the time and temperature should appear on the screen.
16. Turn the dial until  appears at the bottom of the screen.

---

## 6. FAULT FINDING

### 6.1 RELAY AND SENSOR TEST

(Pages 15 & 16 in E8.4401 System Manager Operating Instructions manual)

1. When the front cover is open **"DISPLAY"** appears followed by **"INSTALLATION"**. Rotate the dial anticlockwise until **"SERVICE"** appears.
2. Press the **"Select"** button and **"RELAY TEST"** appears on the screen.
3. Press **"Select"** and **"CODE NO."** appears on the screen.
4. Press **"Select"** 5 times (0000) (red led goes off).
5. Press **"Select"** to enter **"RELAY TEST"** (red led comes on).
6. Rotate the dial to choose the relay you want to check.
7. Press **"Select"** to return.
8. Rotate the dial until **"SENSOR TEST"** appears on the screen.
9. Press **"Select"** button (red led comes on).
10. Rotate the dial to choose which sensor you want to test.
11. Press **"Select"** when finished (red led goes off).
12. Close the front cover.

---

## 6.2 DISPLAY OUTSIDE TEMPERATURE

(Page 19 in E8.4401 System Manager Operating Instructions manual)

1. When the front cover is open **"DISPLAY"** appears followed by **"INSTALLATION"**. Rotate the dial until **"USER"** appears.
2. Press the **"Select"** button and **"ENGLISH"** appears on the screen.
3. Turn the dial until **"DISPLAY SEL"** appears.
4. Press **"Select"** (red led comes on).
5. Turn dial until **"T-OUTSIDE"** appears.
6. Press **"Select"**.
7. Close the lid.

---

## 6.3 RESET TO FACTORY SETTING

(Page 18 in E8.4401 System Manager Operating Instructions manual)

1. When the front cover is open **"DISPLAY"** appears followed by **"INSTALLATION"**. Rotate the dial anticlockwise until **"SERVICE"** appears.
2. Press the **"Select"** button and **"RELAY TEST"** appears on the screen.
3. Rotate the dial until **"SERVICE"** appears.
4. Press **"Select"** and **"CODE NO."** appears on the screen.
5. Press **"Select"** 5 times (0000) (red led goes off).
6. Rotate the dial until **"RESET USER"** appears.
7. To reset user, press **"Select"** and change to 01 using the dial.
8. Press **"Select"**.
9. Rotate the dial until **"RESET EXPERT"** appears.
10. To reset expert, press **"Select"** and change to 01 using the dial.
11. Press **"Select"**.
12. Rotate the dial until **"RESET T-PRG"** appears.
13. To reset time programme, press **"Select"** and change to 01 using the dial.
14. Press **"Select"**.
15. Turn the dial until **"RETURN"** appears.
16. Press "Select" to return to **"SERVICE"**.
17. Close the front cover.

---

## 6.4 HEADER TEMPERATURE INCREASE

(Page 31 in E8.4401 System Manager Operating Instructions manual)

If you require a higher temperature in the Low Loss Header tank, you can programme the controller to run the boilers to a higher temperature as follows:

1. Go to **"EXPERT"** area.
2. Press **"SELECT"**.
3. Enter the code.
4. Turn the dial until you get to **"MAX T-HEADER"**.
5. Press **"SELECT"**.
6. Adjust +/- as required.
7. Press **"SELECT"**.
8. Turn the dial until you get to **"MIN T-HEADER"**.
9. Press **"SELECT"**.
10. Adjust +/- as required.
11. Close the lid.

---

## 6.5 TURN OFF WEATHER COMPENSATION

(Page 24 in E8.4401 System Manager Operating Instructions manual - Heatslope)

If you do not want the outside temperature to govern the controller, you can disable it by changing the "HEATSLOPE" setting as follows:

1. Go to **"USER AREA"**.
2. Turn the dial to get to **"HTG CIRCUIT 1"**.
3. Press **"SELECT"**.
4. Turn the dial to get to **"HEATSLOPE"**.
5. Press **"SELECT"**.

Turn the dial anticlockwise to reduce the setting from 1.2 to 0.0 (A table explaining this setting is on page 24 of Cascading Boiler System manual). (check page number!)

6. Close the lid.

The controller may take up to 24 hours to adjust its internal calibration for this setting to take effect. When possible, change this setting in stages of .25 over a period of 5 days. This will help the controller to calibrate itself more effectively.

---

## 7. TIME PROGRAMMING

(Pages 27-30 in E8.4401 System Manager Operating Instructions manual)

The controller has up to 3 heating periods per day, **"1 ON/OFF"**, **"2 ON/OFF"** and **"3 ON/OFF"** (a minimum of one heating period needs to be selected in order for the unit to operate).

1. Open the front lid and rotate the dial until **"Time Program"** appears.
2. Rotate the dial to choose either **"HTG-PROG 1"**, **"HTG-PROG 2"** or **"DHW-PROG"**, depending on which system you would like to control.
3. Press the **"Select"** button, **"MONDAY"** appears.
4. Press the **"Select"** button **"1 ON"** appears.
5. Turn the dial; choose the start time you require the 1<sup>st</sup> heating period to begin.
6. Press the **"Select"** button, **"1 OFF"** appears.
7. Turn the dial; choose the start time you require the 1<sup>st</sup> heating period to finish.
8. Press the **"Select"** button, **"2 ON"** appears.
9. Turn the dial; choose the start time you require the 2<sup>nd</sup> heating period to begin.
10. Press the **"Select"** button, **"2 OFF"** appears.
11. Turn the dial; to choose what time you require the 2<sup>nd</sup> heating period to finish.
12. Press the **"Select"** button, **"3 ON"** appears.
13. Turn the dial, choose the start time you require the 3<sup>rd</sup> heating period to begin.
14. Press the **"Select"** button, **"3 OFF"** appears.
15. Turn the dial; to choose what time you require the 3<sup>rd</sup> heating period to finish.
16. Press select and **"TUESDAY"** appears (begin again at step 4).

Repeat for the remaining days of the week.

Close the lid and turn the dial until the clock symbol 1 appears.

---

## 8. WARRANTY

Please refer to the E8.4401 System Manager Operating Instructions manual that accompanies this unit for further details on warranty.

The warranty will only apply if the appliance is installed by a qualified, competent person and is serviced/checked annually thereafter.

The following terms, laid out in the warranty must be adhered to:

- (a) All claims under the warranty must be received within 5 years from the date of installation.
- (b) The Cascading Management Controller must be installed and commissioned by a qualified, competent person and as set out in this instruction manual.
- (c) Installation of the Cascading Management Controller must be in accordance with this manual and all relevant standards and codes of practice.
- (d) Firebird can accept no liability in respect of any defect arising from incorrect installation, negligence, fair wear and tear, misuse, alteration or repair by unqualified persons.
- (e) The warranty extends to reasonable labour costs except under clause (a), where any valid claim made after 3 years will not include labour costs.
- (f) Firebird's prior authorisation must be obtained before examination or repair of the appliance takes place.
- (g) Firebird will examine all claims made under the warranty and for any claims deemed invalid, costs incurred will be borne by the customer.
- (h) Any defective part removed under any or all of the warranties **MUST** be returned to Firebird

**This unit MUST be earthed.**



## HEATING SOLUTIONS

Please complete the following details to register your Firebird Cascading Management Controller Warranty/Commissioning Card.

### CUSTOMER

Name: .....

Address: .....

.....

.....

Tel: .....

### INSTALLER

Name: .....

Address: .....

.....

.....

Tel: .....

### Controller

Serial Number: .....

Combined boiler output to system ..... kW.

Total number of boilers connected to the LLH .....

System is installed in accordance with manual guidelines.

System is installed in accordance with building regulations.

### Commissioning and Handover Details

System brought up to temperature by undersigned, operating safely and transferring heat.

Manuals handed to householder.

Installer Signature: .....

Date: .....



CUT ALONG DOTTED LINE



CUT ALONG DOTTED LINE





## CUSTOMER SERVICE

Firebird pride themselves on offering the highest levels of customer service possible. The level of service provided is monitored on a regular basis to ensure customers' requirements are always met.



## TECHNICAL SUPPORT

Our Technical Team provides customers with a comprehensive technical support package which is designed to make the specification and installation process as simple as possible. For technical support please contact the Firebird Technical Team on **026 45253** or [service@firebird.ie](mailto:service@firebird.ie)



## QUALITY

All Firebird products are produced to the highest quality standards and are put through rigorous testing procedures by external standards agencies. Every product is designed to meet a specific requirement and has been manufactured using premium quality materials to precise standards and tolerances.



## WARRANTY

Please refer to E8.4401 System Manager Operating Instructions manual for warranty details.



**Firebird Heating Solutions Ltd.**  
Údarás Industrial Estate,  
Baile Mhic Íre, Co. Cork,  
Ireland,  
P12 HK51

**Firebird Heating Solutions Ltd.**  
Shean, Forkhill,  
Newry,  
BT35 9SY

**Firebird Products Ltd,**  
Phoenix House,  
Eastern Wood Road,  
Langage Industrial Estate,  
Plympton,  
Plymouth,  
PL7 5ET

t: +353 (0)26 45253  
f: +353 (0)26 45309  
e: [info@firebird.ie](mailto:info@firebird.ie)  
[www.firebird.ie](http://www.firebird.ie)

t: +44 (0)28 3088 8330  
f: +44 (0)28 3088 9096  
e: [firebirdproducts@hotmail.co.uk](mailto:firebirdproducts@hotmail.co.uk)  
[www.firebird.ie](http://www.firebird.ie)

t: +44 (0)1752 691177  
f: +44 (0)1752 691131  
e: [sales@firebird.uk.com](mailto:sales@firebird.uk.com)  
[www.firebird.uk.com](http://www.firebird.uk.com)