

100%  
IRISH

*An rogha is fearr*

**FIREBIRD**



**HEATING SOLUTIONS**

# ENVIROAIR

Air Source Heat Pumps

INSTALLATION & OPERATION MANUAL



[www.firebird.ie](http://www.firebird.ie)



ENVIRONMENT



INNOVATION



TECHNOLOGY



---

# Contents

	Page
Introduction	4
1. General Information	6
2. Safety	6
3. Transportation and Handling	8
4. Before Operation	8
5. General Dimensions	9
6. Unit Installation	12
7. Refrigerant and Water Piping	14
8. Drain Piping	15
9. Electrical and Control Settings	22
10. Commissioning	29
11. Unit Controller	31
12. Wireless Intelligent Room Thermostat	42
13. Main Safety Devices	48
14. Hybrid Systems	49
15. Trouble Shooting	52

## Introduction

Specifications in this manual are subject to change without notice in order that Firebird may bring the latest innovations to their customers.

Whilst every effort is made to ensure that all specifications are correct, printing errors are beyond Firebird's control; Firebird cannot be held responsible for these errors.

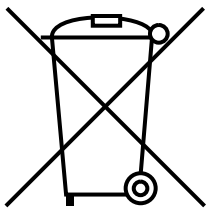

### CAUTION

This product shall not be mixed with general household waste at the end of its life and it shall be retired according to the appropriated local or national regulations in a environmentally correct way.

Due to the refrigerant, oil and other components contained in heat pump, its dismantling must be done by a professional installer according to the applicable regulations. Please contact the relevant authorities for more information.

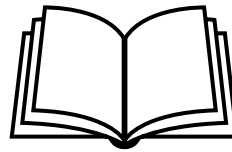

Following Regulation EU No. 517/2014 on Certain Fluorinated Greenhouse gases, it is mandatory to fill in the label attached to the unit with the total amount of refrigerant charged on the installation.



Do not vent R410A into the atmosphere: R410A are fluorinated greenhouse gases covered by the Kyoto protocol global warming potential (GWP) R410A = 2088.

Tn of CO<sub>2</sub> equivalent of fluorinated greenhouse gases contained is calculated by indicated GWP \* Total Charge (in kg) indicated in the product label and divided by 1000.

Models Codification

Important note: Please, check, according to the model name, which is your heat pump type, how it is abbreviated and referred to in this instruction manual. This Installation and Operation Manual is only related to Firebird Enviroair Outdoor Units.

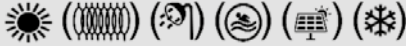
**Enviroair Air to Water Heat Pump Models**

 1- 230V 50Hz	
Unit	
Enviroair 7.5kW	-
-	Enviroair 11kW
-	Enviroair 14kW
-	Enviroair 16kW
	

**i NOTE**

*Icons between brackets mean possible extra operations to the factory-supplied operations.*

# 1. General Information

No part of this publication may be reproduced, copied, filed or transmitted in any shape or form without the permission of Firebird.

Within the policy of continuous improvement of its products, Firebird reserves the right to make changes at any time without prior notification and without being compelled to introducing them into products subsequently sold. This document may therefore have been subject to amendments during the life of the product.

Firebird makes every effort to offer correct, up-to-date documentation. Despite this, printing errors cannot be controlled by Firebird and are not its responsibility.

As a result, some of the images or data used to illustrate this document may not refer to specific models. No claims will be accepted based on the data, illustrations and descriptions included in this manual.

---

# 2. Safety

---

## 2.1 Applied Symbols

During normal heat pump system design work or unit installation, greater attention must be paid in certain situations requiring particular care in order to avoid injuries or damage to the unit, the installation or the building or property.

Situations that jeopardise the safety of those in the surrounding area or that put the unit itself at risk will be clearly indicated in this manual.

To indicate these situations, a series of special symbols will be used to clearly identify these situations.

Pay close attention to these symbols and to the messages following them, as your safety and that of others depends on it.

### DANGER

- The text following this symbol contains information and instructions relating directly to your safety and physical wellbeing.
- Not taking these instructions into account could lead to serious, very serious or even fatal injuries to you and others in the proximities of the unit.

In the text following the danger symbol you can also find information on safe procedures during unit installation.

### CAUTION

- The text following this symbol contains information and instructions relating directly to your safety and physical wellbeing.
- Not taking these instructions into account could lead to minor injuries to you and others in the proximities of the unit.
- Not taking these instructions into account could lead to unit damage.

In the text following the caution symbol you can also find information on safe procedures during unit installation.

### NOTE

- *The text following this symbol contains information or instructions that may be of use or that require a more thorough explanation.*
  - *Instructions regarding inspections to be made on unit parts or systems may also be included.*
- 

## 2.2 Additional Information About Safety

### DANGER

- Do not connect the power supply to the unit prior to filling the space heating circuit (and dhw circuit if it were the case) with water and checking water pressure and the total absence of any water leakage.
- Do not pour water over the unit electrical parts. If the electrical components are in contact with water a serious electrical shock will take place.
- Do not touch or adjust the safety devices inside the air to water heat pump. If these devices are touched or adjusted, a serious accident can take place.
- Do not open the service cover or access inside the air to water heat pump without disconnecting the main power supply.
- In case of fire turn OFF the main switch, put out the fire at once and contact your service contractor.
- It must ensure that the air to water heat pump cannot operate accidentally without water neither with air inside hydraulic system.

### CAUTION

- Do not use any sprays such as insecticide, lacquer, hair spray or other flammable gases within approximately one meter from the system.
- If installation circuit breaker or the unit fuse is often activated, stop the system and contact your service contractor.
- Do not make service or inspections tasks by yourself. This work must be performed by a qualified service person.
- This appliance must be used only by adult and capable people, having received the technical information or instructions to handle this appliance properly and safely.
- Children should be supervised to ensure that they do not play with the appliance.
- Do not let any foreign body into the water inlet and outlet piping of the air to water heat pump.

### 2.3 Important Notice

- Verify, in accordance with the manuals which appear in the unit, that all the information required for the correct installation of the system is included. If this is not the case, contact your distributor.
- Firebird pursues a policy of continuous improvement in product design and performance. The right is therefore reserved to vary specifications without notice.
- Firebird cannot anticipate every possible circumstance that might involve a potential hazard.
- This air to water heat pump has been designed for standard water heating for human beings only. Do not use this for other purposes such as for drying clothes, heating foods or for any other heating process (except swimming pool).
- No part of this manual may be reproduced without written permission.
- If you have any questions, contact Firebird Products Ltd.
- Check and make sure that the explanations of each part of this manual correspond to your air to water heat pump model.
- Refer to the models codification to confirm the main characteristics of your system.
- Signal words (NOTE, DANGER and CAUTION) are used to identify levels of hazard seriousness. Definitions for identifying hazard levels are provided in initial pages of this document.
- The operation modes of these units are controlled by the unit controller.
- This manual should be considered as a permanent part of the air to water heat pump. It gives a common description of and information for this air to water heat pump which you operate as well as for other models.
- Keep the water temperature of the system above the freezing temperature.

#### **CAUTION**

Do not pass cables through the ventilation hole.

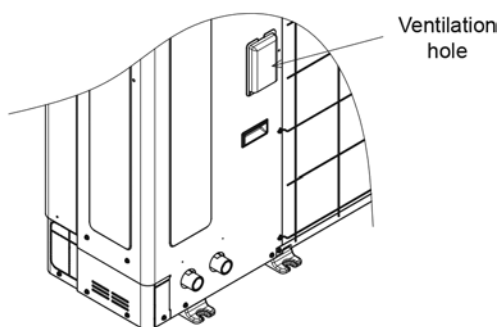

#### **DANGER**

**Pressure Vessel and Safety Device:** This heat pump is equipped with a high pressure vessel under PED (Pressure Equipment Directive). The pressure vessel has been designed and tested before shipment according to PED. Also, in order to prevent the system from an abnormal pressure, a high pressure switch, which needs no field adjustment, is utilised in the refrigeration system. Therefore, this heat pump is protected from abnormal pressures. However, if abnormally high pressure is applied to the refrigeration cycle including the high pressure vessel(s), it will result in serious injury or death due to explosion of the pressure vessel. Do not apply a pressure higher than the following pressure to the system, by modifying or changing the high pressure switch.

#### **CAUTION**

**Start-up and Operation:** Check to ensure that all the stop valves are fully opened and no obstacle exists at the inlet / outlet sides before start-up and during the operation.

**Maintenance:** Periodically check the high pressure side pressure. If the pressure is higher than the maximum allowable pressure, stop the system and clean the heat exchanger or remove the cause.

Maximum Allowable Pressure and High Pressure Cut-out Value:

Refrigerant	Maximum Allowable Pressure (MPa)	High Pressure Switch Cut-out Value (MPa)
R410A	4.15	4.00 - 4.10

#### **NOTE**

The label for the vessel under PED are attached on the high pressure vessel. The pressure vessel capacity and vessel category are indicated on the vessel.

#### Location of High Pressure Switch

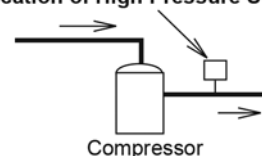

#### **NOTE**

The high pressure switch is indicated on the electrical wiring diagram in the outdoor unit as PSH connected to printed circuit board (PCB1) in the outdoor unit.

#### Structure of High Pressure Switch

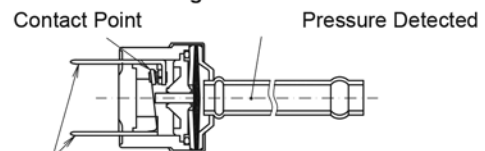

Connected to the electrical wire

#### **DANGER**

Do not change the high-pressure switch locally or change the high pressure cut-out set value locally. If changed, it will cause serious injury or death due to explosion.

Do not attempt to turn service valve rod beyond its stop.

### 3. Transportation and Handling

When hanging the unit, ensure a balance of the unit, check safety and lift it up smoothly.

Do not remove any packing materials.

Hang the unit under packing condition with two ropes.

For safety reasons ensure that the outdoor unit is lifted smoothly and does not lean.

Model	Gross weight (kg)
Enviroair 7.5kW	115
Enviroair 11kW	135
Enviroair 14kW	140
Enviroair 16kW	153

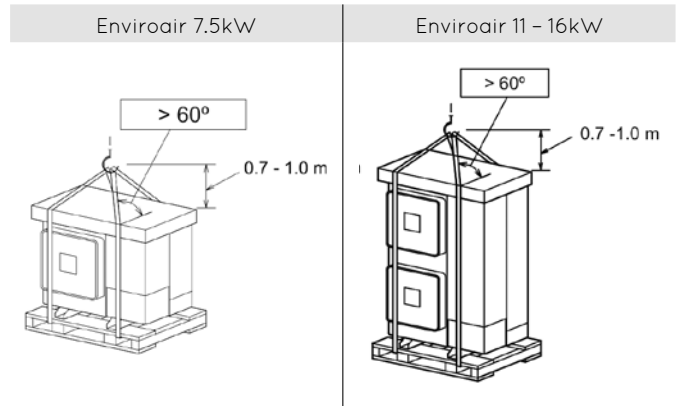

### 4. Before Operation

#### ⚠ CAUTION

- Supply electrical power to the system for approximately 12 hours before start-up or a long shut-off. Do not start the system immediately after power supply, it may cause a compressor failure because the compressor is not heated well.
- When the system is started after a shut-off longer than approximately 3 months, it is recommended to check the system by your service contractor.
- Turn OFF the main switch when the system is to be stopped for a long period of time: If the main switch is not turned OFF, electricity will be used, because the oil heater is always energised during compressor stopping.
- Make sure that the outdoor unit is not covered with snow or ice. If covered, remove it by using hot water (approximately 50°C). If the water temperature is higher than 50 °C, it will cause damage to plastic parts.

#### 4.1 Factory-Supplied Unit Components

Accessory	Image	Qty.	Purpose
Gasket		4	Two gaskets for each space heating connections (inlet / outlet)
Instruction manual		1	
Declaration of conformity	-	1	Basic instructions for the installation of the device

#### **i** NOTE

- The previous accessories are supplied inside the unit.
- If some of these accessories are not packed with the unit or any damage to the unit is detected, please contact your dealer.

## 5. General Dimensions

### 5.1 Service Space

#### Enviroair 7.5kW

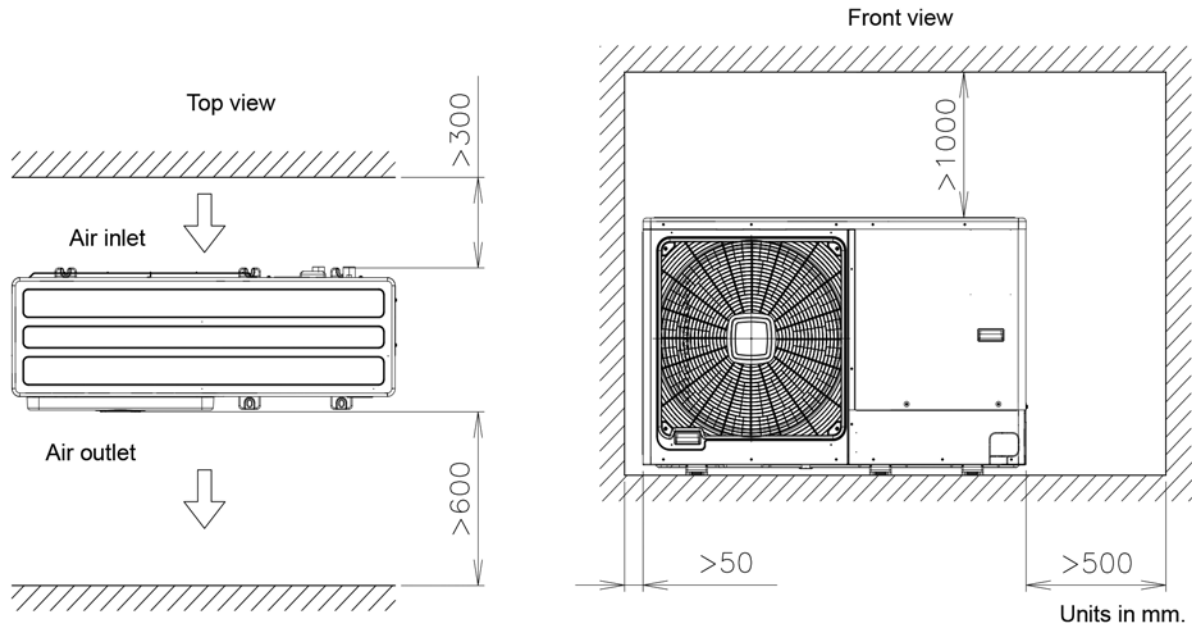

#### Enviroair 11-16kW

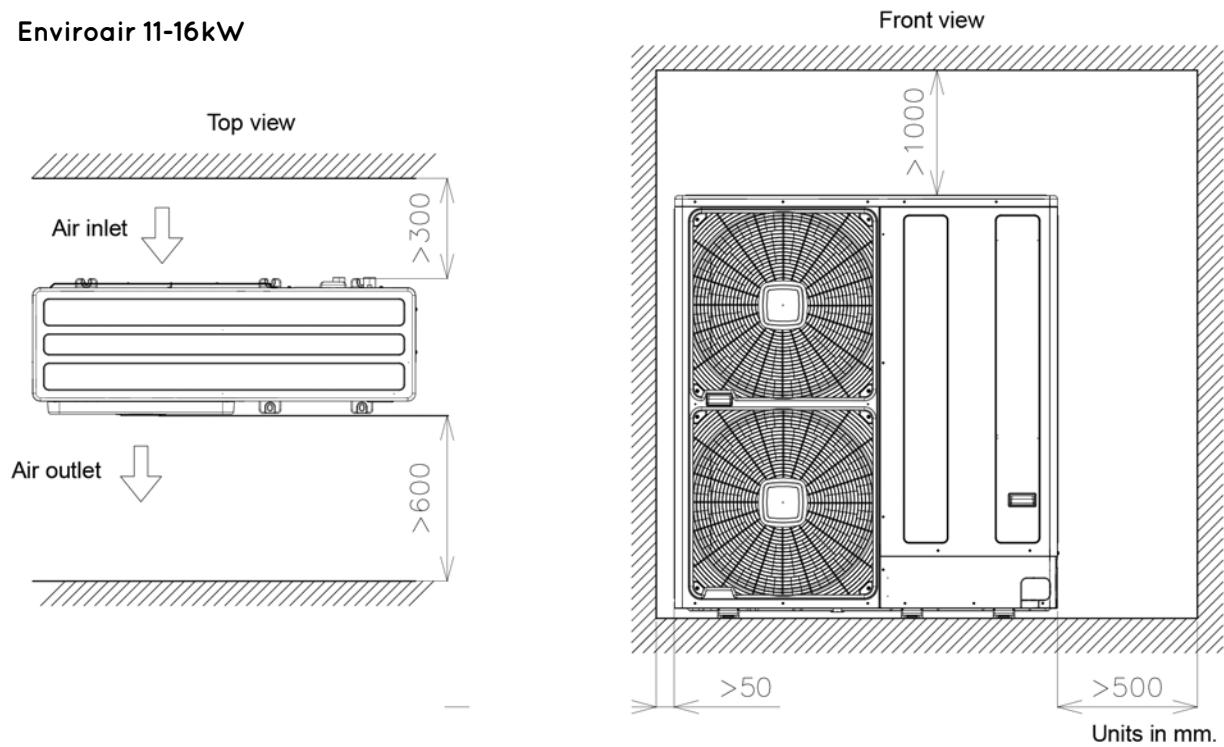

## 5.2 Name of Parts and Dimensional Data

### Enviroair 7.5kW

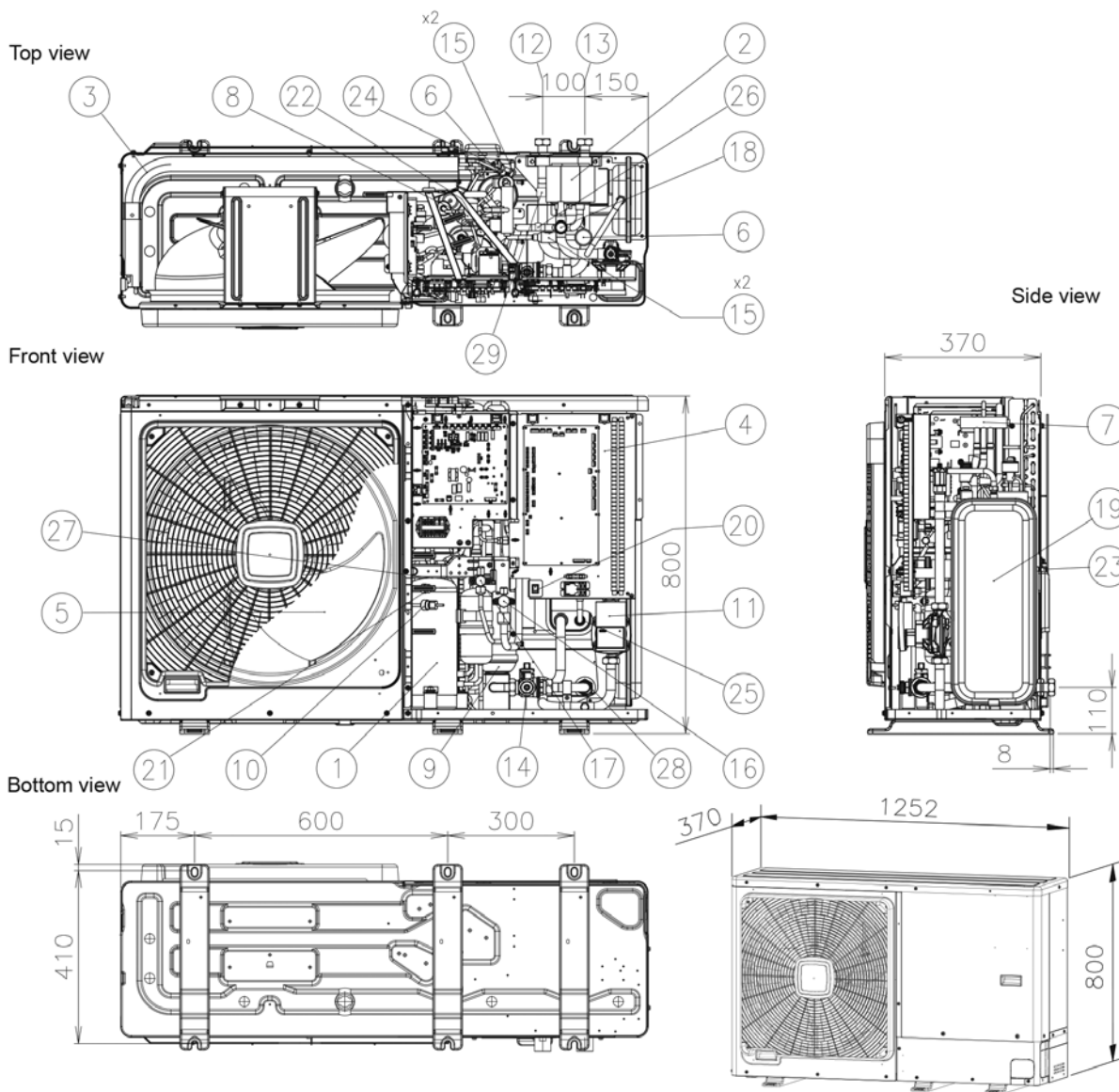

No.	Part name
1	Compressor
2	Water side heat exchanger
3	Air side heat exchanger
4	Electrical box
5	Fan (x1)
6	Expansion valve (x2)
7	Reversing valve
8	Solenoid valve
9	Accumulator
10	High pressure switch (PSH)
11	Water pump
12	Water outlet - G 1"
13	Water inlet - G 1"
14	Water strainer
15	Refrigerant strainer (x4)

No.	Part name
16	Stop valve for gas line - Ø15.88 (5/8")
17	Stop valve for liquid line - Ø9.52 (3/8")
18	Safety valve
19	Expansion vessel 6L
20	Switch for DHW "emergency" operation
21	Sensor for refrigerant pressure
22	Pressure switch for control (Pd)
23	Ambient thermistor
24	Evaporating temperature thermistor
25	Refrigerant liquid pipe thermistor
26	Refrigerant gas pipe thermistor
27	Compressor discharge thermistor
28	Water inlet thermistor
29	Water outlet thermistor



## 5.2 Name of Parts and Dimensional Data

### Enviroair 11-16kW

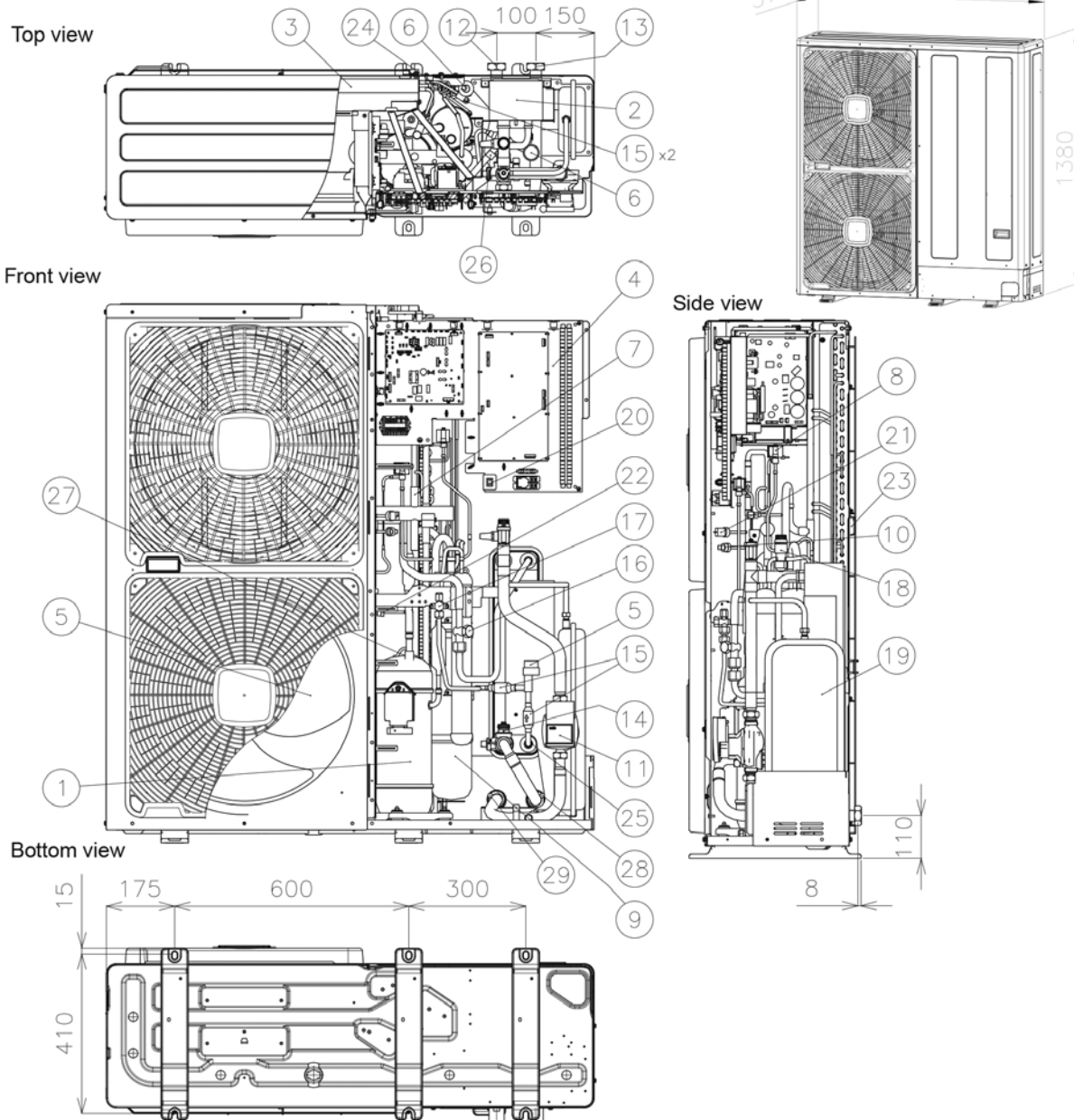

No.	Part name
1	Compressor
2	Water side heat exchanger
3	Air side heat exchanger
4	Electrical box
5	Fan (x2)
6	Expansion valve (x2)
7	Reversing valve
8	Solenoid valve
9	Accumulator
10	High pressure switch (PSH)
11	Water pump
12	Water outlet - G 1 1/4"
13	Water inlet - G 1 1/4"
14	Water strainer
15	Refrigerant strainer (x4)

No.	Part name
16	Stop valve for gas line - Ø25.4 (1")
17	Stop valve for liquid line - Ø9.52 (3/8")
18	Safety valve
19	Expansion vessel 6L
20	Switch for DHW "emergency" operation
21	Sensor for refrigerant pressure
22	Pressure switch for control (Pd)
23	Ambient thermistor
24	Evaporating temperature thermistor
25	Refrigerant liquid pipe thermistor
26	Refrigerant gas pipe thermistor
27	Compressor discharge thermistor
28	Water inlet thermistor
29	Water outlet thermistor



## 6. Unit Installation

### ⚠ CAUTION

- Transport the products as close to the installation location as possible before unpacking.
- Do not put any material on the products.

### ⚠ DANGER

- Install the unit with sufficient clearance around it for operation and maintenance as shown in the next figures. Install the unit where good ventilation is available.
- Do not install the unit where there is a high level of oil mist, salty air or sulphurous atmosphere.
- Install the unit as far as practical (being at least 3 meters) from electromagnetic wave radiator (such as medical equipment).
- For cleaning, use non-inflammable and nontoxic cleaning liquid.
- Use of inflammable agent could cause explosion or fire.
- Work with sufficient ventilation, when working in an enclosed space as this could cause oxygen deficiency. Toxic gas could be produced when cleaning agent is heated.

- Install the unit in a location where noise emitted by the unit does not disturb neighbours.
- Cleaning liquid shall be collected after cleaning.
- Pay attention not to clamp cables when attaching the service cover to avoid electric shock or fire.

### ⚠ CAUTION

- When installing more than one unit together, keep clearance between the units to more than 500 mm, and avoid obstacles that could hamper air intake.
- Install the unit in the shade or not exposed to direct sunshine or direct radiation from high temperature heat source.
- Do not install the unit in a space where a seasonal wind directly blows to the Outdoor fan.
- Make sure that the foundation is flat, level and sufficiently strong.
- This unit has aluminium fins with sharp edges. Pay attention to the fins to avoid injury. Install the unit in a restricted area not accessible by the general public.

### 6.1 Installation Space

(Unit: mm)

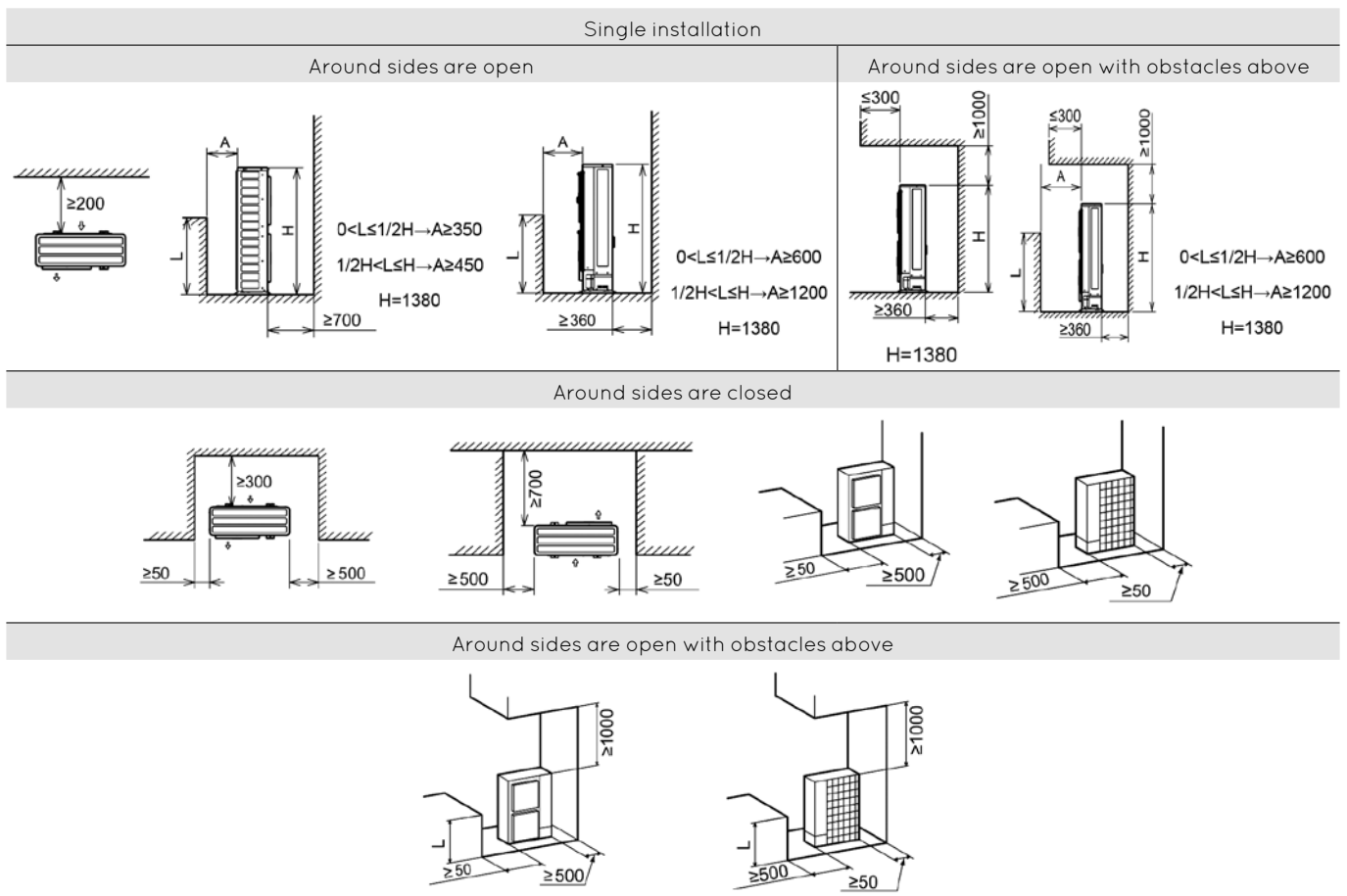

(Unit: mm)

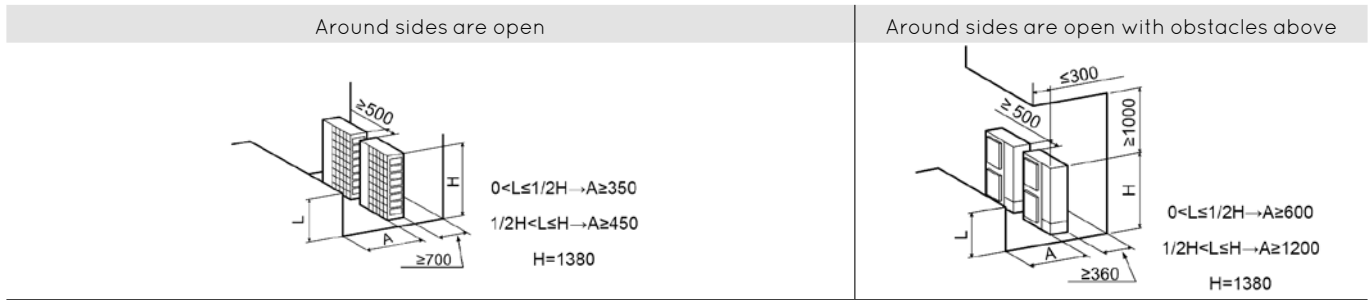

## 6.2 Place Provision

### Concrete foundation

- Foundation shall be on a level surface and it is recommended to be 100-300 mm higher than ground level.
- Use M10 anchor bolts to fix the unit to the foundation. (Foundation bolts, nuts and washers are not included, and must be field supplied).
- Drain water might turn into ice on cold weather areas. Therefore, when installing the unit on a roof or a veranda, avoid the draining on a public area since it may become slippery.

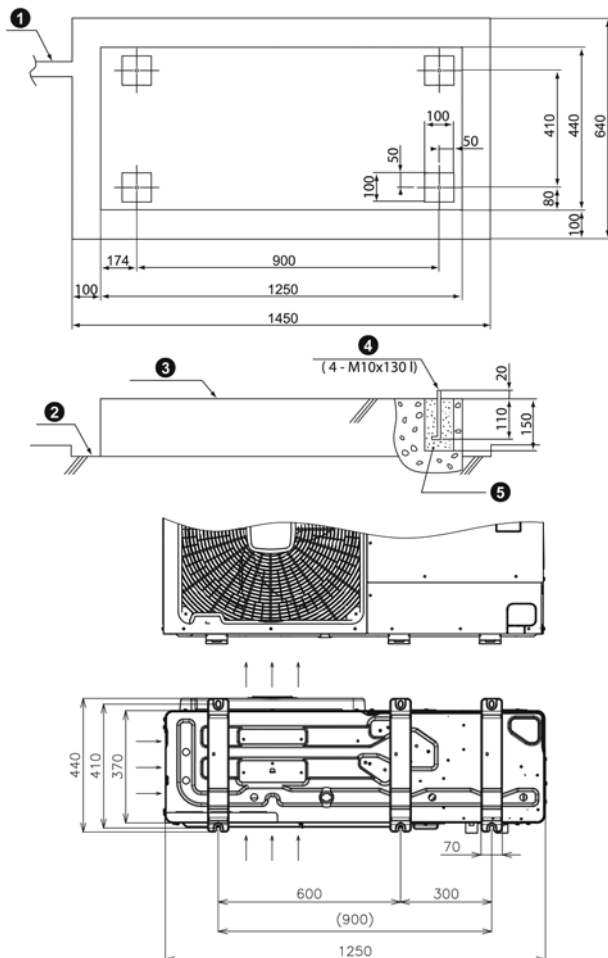

No.	Description
①	Drain water
②	Drain water place
③	Concrete base
④	Foundation bolt
⑤	Mortar charge

The whole of the base of the Enviroair unit should be installed on a foundation. When using a vibration-proof mat, it should also be positioned the same way. When installing the Enviroair unit on a field supplied frame, use metal plates to adjust the frame width for stable installation as shown in below figure.

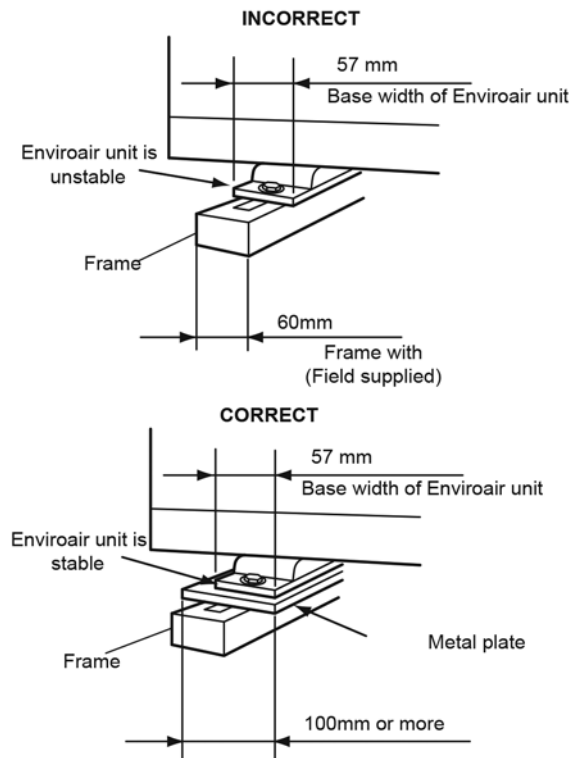

Recommended metal plate size

- (Field-supplied) material: hot-rolled mild steel
- Plate (SPHC) plate thickness: 4.5 T

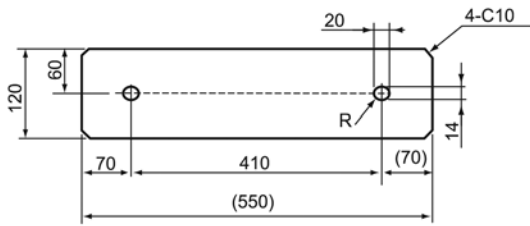

- The foundation drawing shown previously is an example.
- The unit is low-vibration model, but consider using some floor reinforcement or anti-vibration mat / rubber when vibration should occur due to weakness of attached surface.
- The foundation shall be unified with the floor slab. If not, calculate the vibration proof of the installation of Enviroair Unit as well as of the Enviroair Unit with the foundation in order to ensure strength against a fall or for when the unit has to be moved.
- Drain water and rainwater are discharged from the bottom of the unit when in operation as well as when stopped.
- Choose a location with good drainage or place a water drain as in the drawing.
- Make the foundation flat and waterproof, as a water pool may appear in case of, for instance, rain.
- This is a low-profile product with a shallow depth. It may also be able to fix on the wall as shown below when fixing only with the foundation bolt does not seem sufficiently stable depending on the conditions of the installation (metal fittings must be field supplied).

### Fix unit to the wall

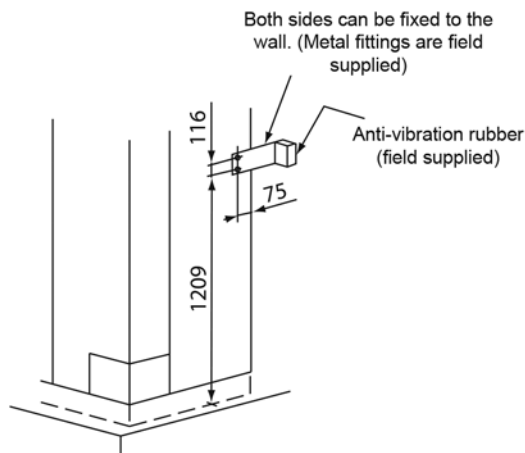

- 1 Fix the unit onto the wall as indicated in the figure (stay field supplied).
- 2 The foundation shall be strong enough to avoid any deformation and vibration.
- 3 In order to prevent vibration transfer to the building, place rubber material between the stay and the wall.

### CAUTION

Pay attention to the following for installation:

- Installation shall ensure that unit will not incline, vibrate, make noise or fall down by a blast of wind or in an earthquake. Calculate quake resistance strength to ensure that installation is strong enough against falling. Fix the unit with wires (field supplied) when installing in a location without walls or windbreak and likely exposed to a blast of wind.
- Apply vibration-proof material where necessary.

### Installing location where the unit will be exposed to strong wind

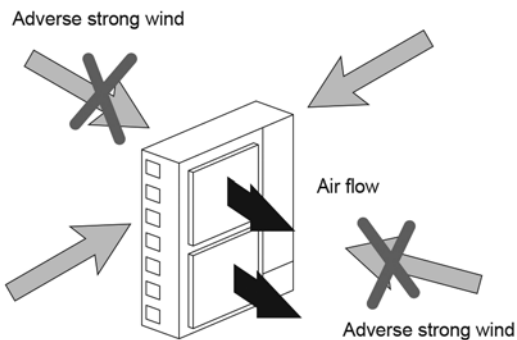

Strong winds against the unit's air outlet causes short circuits and these can be the consequences:

- Lack of air flow and adversely affect to normal function.
- Frequent frost acceleration.
- Fan can rotate very fast until it breaks.

Follow the instructions below to install on a rooftop or a location without surrounding buildings, where strong wind is expected against the unit.

- 1 Choose a location where the outlet or inlet side of the product will not be exposed to strong wind.
- 2 In case the fulfillment of point 1 is not possible, it is recommended to use the optional parts.

### CAUTION

Excessive strong wind against the unit outlet may cause inverse rotation and damage the fan motor.

## 7. Refrigerant and Water Piping

### 7.1 General Notes Before Performing Piping Work

- Prepare locally supplied copper pipes.
- Select the piping size with the correct thickness and correct material able to withstand sufficient pressure.
- Select clean copper pipes. Make sure that there is no dust or moisture inside the pipes. Blow the inside of the pipes with oxygen free nitrogen to remove any dust and foreign materials before connecting them.

### NOTE

*A system with no moisture or oil contamination will give maximum performance and life cycle compared to that of a poorly prepared system. Take particular care to ensure that all copper piping is clean and dry internally.*

- Cap the end of the pipe when pipe is to be inserted through a wall hole.
- Do not put pipes on the ground directly without a cap or vinyl tape at the end of the pipe.

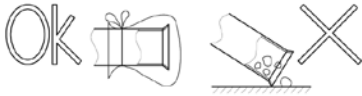

- If piping installation is not completed until next day or over a longer period of time, braze off the ends of the piping and charge with oxygen free nitrogen through a Schrader valve type access fitting to prevent moisture and particle contamination.

- It is advisable to insulate the water pipes, joints and connections in order to avoid heat loss and dew condensation on the surface of the pipes or accidental injuries due to excessive heat on piping surfaces.
- Do not use insulation material that contains NH<sub>3</sub>, as it can damage copper pipe material and become a source of future leakage.
- It is recommended to use flexible joints for the water piping inlet and outlet in order to avoid vibration transmission.
- Water circuit must be performed and inspected by a licensed technician and must comply with all relevant European and national regulations.
- Proper water pipe inspection should be performed after piping work to assure there is no water leakage in the space heating circuit.

## 7.2 Refrigerant Circuit

### 7.2.1 Refrigerant charge

The R410A refrigerant is factory charged in the outdoor unit.

### 7.2.2 Precautions in the event of gas refrigerant leaks

The installers and those responsible for drafting the specifications are obliged to comply with local safety codes and regulations in the case of refrigerant leakage.

#### CAUTION

- Check for refrigerant leakage in detail. If a large refrigerant leakage occurred, it would cause difficulty with breathing or harmful gases would occur if a fire were in the room.
- If the flare nut is tightened too hard, it may crack over time and cause refrigerant leakage.

### Maximum permitted concentration of HFCs

The refrigerant R410A (charged in the outdoor unit) is an incombustible and non-toxic gas. However, if leakage occurs and gas fills a room, it may cause suffocation.

The maximum permissible concentration of HFC gas according to EN378-1 is:

Refrigerant	Maximum permissible concentration (kg/m <sup>3</sup> )
R410A	0.44

## 8. Drain Piping

### 8.1 Water Drain Discharge Connection (Accessory)

When the base of the unit is temporarily used as a drain receiver or the drain water in it is discharged, this drain boss is used to connect the drain piping.

Model	Applicable Model
DBS-26	Enviroair 7.5-16kW

#### Connecting procedure

- 1 Insert the rubber cap into the drain boss up to the extruded portions.
- 2 Insert the boss into the unit base and turn approximately 40 degree counter-clockwise.
- 3 Size of the drain boss is 32 mm (O.D.).
- 4 A drain pipe should be field-supplied.

#### NOTE

*Do not use this drain boss set in a cold area because the drain water should freeze. This drain boss is not sufficient to collect all the drain water. If collecting drain water is completely required, provide a drain-pan that is bigger than the unit base and install it under the unit with drainage.*

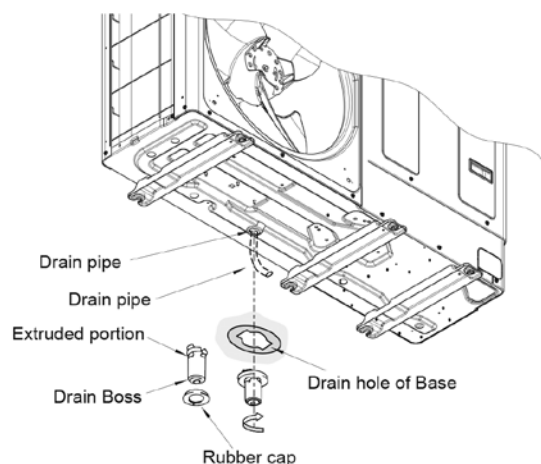

### 8.2 Space Heating and DHW

#### **⚠ DANGER**

Do not connect the power supply to the unit prior to filling the space heating circuit (and DHW circuit if it were the case) with water and checking water pressure and the total absence of any water leakage.

#### 8.2.1 Additional hydraulic elements necessary for space heating

Nature	No.	Part name
Piping connections	1	Water inlet (space heating)
	2	Water outlet (space heating)
Field supplied	3	Shut-off valve (field supplied)
Accessories	4	Water check valve
Field supplied	5	Shut-off valve

The following hydraulic elements are necessary to correctly perform the space heating water circuit:

- Two shut-off valves (field supplied accessory) (3) must be installed in the unit. One at the water inlet connection (1) and the other at the water outlet connection (2) in order to make easier any maintenance work.
- A water check valve (5) with 1 shut-off valve (field supplied) (4) must be connected to the water filling point when filling the unit. The check valve acts as a safety device to protect the installation against back pressure, back flow and back syphon of non-potable water into drinking water supply net.

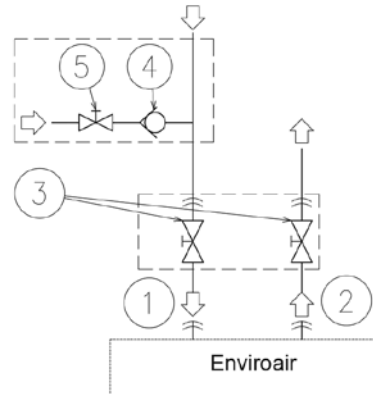

#### 8.2.2 Additional hydraulic elements necessary for DHW

Nature	No.	Part name
Piping connections	1	Water inlet (space heating)
	2	Water outlet (space heating)
	3	Heating coil inlet
	4	Heating coil outlet
	5	Water inlet (DHW)
	6	Water outlet (DHW)
Field supplied	7	Shut-off valve (field supplied)
Accessories	8	Domestic hot water tank
	9	3-way valve
Field supplied	10	T-branch
	11	Heating coil pipes

Enviroair is not factory-supplied ready for DHW operation, but it can be used for the production of DHW if the following elements are installed:

- A domestic hot water tank (8) has to be installed in combination with the unit.
- A 3-way valve (9) must be connected at one point of the water outlet pipe of the installation.
- A T-branch (field supplied) (10) must be connected at one point of the water inlet pipe of the installation.
- Two water pipes (field supplied) (11). One pipe between 3-way valve and the heating coil inlet (3) of the DHW tank, the other one between the T-branch and the heating coil outlet (4) of the DHW tank.

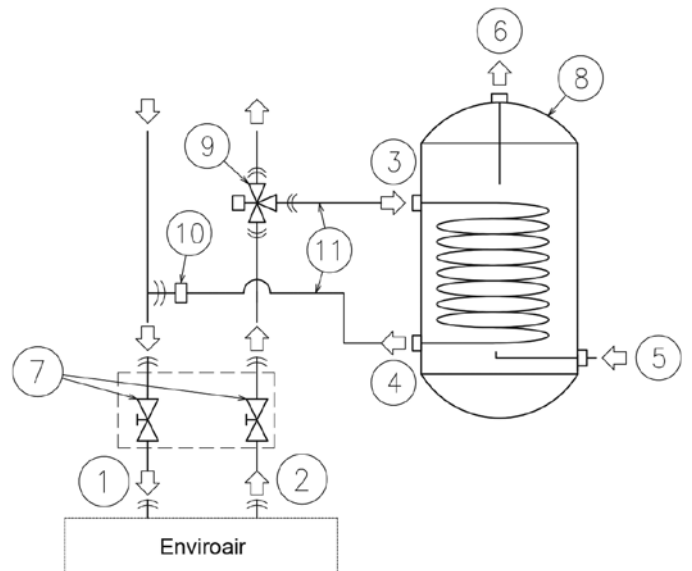

Additionally, the following elements are required for the DHW circuit:

Nature	No.	Part name
Piping connections	1	Water inlet (DHW)
	2	Water outlet (DHW)
Field supplied	3	3a - Shut-off valve
		3b - Water check valve
		3c - Pressure relief valve
	4	Shut-off valve
	5	Draining

- 1 shut-off valve (field supplied): one shut-off valve (4) must be connected after the DHW outlet connection of the DHW tank(2) in order to make easier any maintenance work.
- A security water valve (field-supplied): this accessory (3) is a pressure and temperature relief valve that must be installed as near as possible to the DHW inlet connection of the DHW tank (1). It should ensure a correct draining (5) for the discharge valve of this valve. This security water valve should provide the following:
  - Pressure protection
  - Non-return function
  - Shut-off valve
  - Filling
  - Draining the unit. The check valve acts as a safety device to protect the installation against back pressure, back flow and back syphon of non-potable water into drinking water supply network.

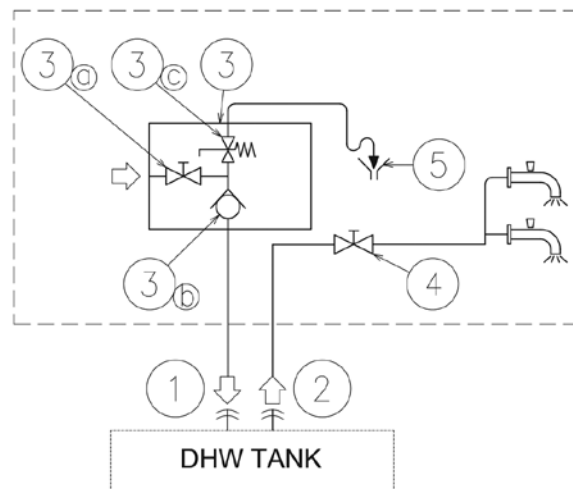

**NOTE**

The discharge pipe should always be open to the atmosphere, free of frost and in continuous slope to the down side in case that water leakage exists.

**8.2.3 Additional hydraulic optional elements (for DHW)**

In case of a recirculation circuit for the DHW circuit:

Nature	No.	Part name
Piping connections	1	Water inlet (DHW)
	2	Water outlet (DHW)
Accessories	3	Water check valve
Field supplied	4	Water pump
	5	Shut-down valve

- 1 recirculation water pump (field supplied): this water pump (3) will help to correctly recirculate the hot water to the DHWinlet.
- 1 water check valve : this Firebird accessory (3) is connected after the recirculation water pump (4) in order to ensure the non-return of water.
- 2 shut-down valves (field supplied) (5): one before the recirculation water pump (4) and other after the water check valve accessory (3)

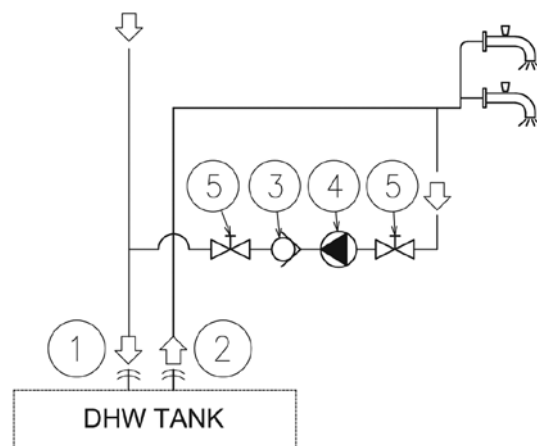

**8.2.4 Requirements and recommendations for the hydraulic circuit**

- The maximum piping length depends on the maximum pressure availability in the water outlet pipe. Please check the pump curves.
- The unit is equipped with an air purger (factory supplied) at the highest location of the unit. If this location is not the highest of the water installation, air might be trapped inside the water pipes, which could cause system malfunction. In that case additional air purgers (field supplied) should be installed to ensure no air enters the water circuit.
- For heating floor system, the air should be purged by means of an external pump and an open circuit to avoid air pockets.
- When the unit is stopped during shut-off periods and the ambient temperature is very low, the water inside the pipes and the circulating pump may freeze, thus damaging the pipes and the water pump. In these cases, the installer shall ensure that the water temperature inside the pipes does not fall below the freezing point. In order to prevent this, the unit has a self-protection mechanism which should be activated.
- Additionally, in cases where water drainage is difficult, an antifreeze mixture of glycol (ethylene or propylene) should be used (content between 10% to 40%). The performance of the unit working with glycol may decrease in proportion to the percentage of glycol used, since the density of glycol is higher than that of the water.
- Check that the water pump of the space heating circuit works within the pump operating range and that the water flow is over the pump's minimum. If the water flow is below 12 litres / minute (6 litres / minute for 7.5kW unit), alarm is displayed on the unit.
- An additional special water filter is highly recommended to be installed on the space heating (field installation), in order to remove possible particles remaining from brazing which cannot be removed by the unit water strainer.
- When selecting a tank for DHW operation, take into consideration the following points:
  - The storage capacity of the tank has to meet with the daily consumption in order to avoid stagnation of water.
  - Fresh water must circulate inside the DHW tank water circuit at least one time per day during the first days after the installation has been performed. Additionally, flush the system with fresh water when there is no consumption of DHW during long periods of time.
  - Try to avoid long runs of water piping between the tank and the DHW installation in order to decrease possible temperature losses.
  - If the domestic cold water entry pressure is higher than the equipment's design pressure (6 bar), a pressure reducer must be fitted with a nominal value of 7 bar.
- When necessary, put insulation on the pipes in order to avoid heat losses.
- Whenever possible, sluice valves should be installed for water piping, in order to minimise flow resistance and to maintain sufficient water flow.
- Ensure that the installation complies with applicable legislation in terms of piping connection and materials, hygienic measures, testing and the possible required use of some specific components like thermostatic mixing valves, differential pressure overflow valve, etc.
- The maximum water pressure is 3 bar (nominal opening pressure of the safety valve). Provide adequate reduction pressure device in the water circuit to ensure that the maximum pressure is NOT exceeded.
- Ensure that the drain pipes connected to the safety valve and to the air purger are properly driven to avoid water being in contact with unit components.
- Make sure that all field supplied components installed in the piping circuit can withstand the water pressure and the water temperature range in which the unit can operate.
- Enviroair units are conceived for exclusive use in a closed water circuit.
- The internal air pressure of the expansion vessel tank will be adapted to the water volume of the final installation (factory supplied with 0.1 MPa of internal air pressure).
- Do not add any type of glycol to the water circuit.
- Drain taps must be provided at all low points of the installation to permit complete drainage of the circuit during servicing.

### 8.2.5 Water filling

- 1 Check that a water check valve with a shut-off valve (field supplied) is connected to the water filling point (water inlet connection) for filling the space heating hydraulic circuit (see “8.2 Space heating and DHW”).
- 2 Make sure all the valves are open (water inlet / outlet shut-off valves and the rest of valves of the space heating installation components).
- 3 Ensure that the air purgers of the unit and installation are open (turn the unit air purger twice at least).
- 4 Check that the drain pipes connected to the safety valve (and to the drain pan in case of installing the “Cooling kit” accessory) are correctly connected to the general draining system. The safety valve is later used as an air purging device during the water filling procedure.
- 5 Fill the space heating circuit with water until the pressure displayed on the manometer reaches approximately 1.8 bar.

#### **i** NOTE

While the system is being filled with water, it is highly recommended to operate the safety valve manually so as to help with the air purging procedure.

- 6 Remove as much air from inside the water circuit as possible through the air purger and other air vents in the installation (fan coils, radiators...).
- 7 Start the air purge procedure test. There are two modes (Manual or Automatic) which helps in case of installations with heating and DHW operation:
  - a. Manual: start and stop the unit manually using the unit controller (run / stop button) and also using the DSW4pin 2 of the PCB1 (ON: Forced to derive to DHW coil; OFF: Forced to derive to space heating).
  - b. Automatic: select the air purge function using the user controller. When the automatic air purge function is running, the pump speed and the position of the 3-way valve (space heating or DHW) are automatically changed:

- 8 If a little quantity of air is still remaining in the water circuit, it will be removed by the automatic air purger of the unit during the first hours of operation. Once the air in the installation has been removed, a reduction of water pressure in the circuit is very likely to occur. Therefore, additional water should be filled until water pressure returns to an approximate level of 1.8 bar.

#### **i** NOTE

- The unit is equipped with an automatic air purger (factory supplied) at the highest location of the unit. Anyway, if there are higher points in the water installation, air might be trapped inside water pipes, which could cause system malfunction. In that case, additional air purgers (field supplied) should be installed to ensure no air enters into the water circuit. The air vents should be located at points which are easily accessible for servicing.
- The water pressure indicated on the unit manometer may vary depending on the water temperature (the higher temperature, the higher pressure). Nevertheless, it must remain above 1 bar in order to prevent air from entering the circuit.
- Fill in the circuit with tap water. The water in the heating installation must comply with EN directive 98/83 EC. Non-sanitary controlled water is not recommended (for example, water from wells, rivers, lakes, etc.).
- The maximum water pressure is 3 bar (nominal opening pressure of the safety valve). Provide adequate reduction pressure device in the water circuit to ensure that the maximum pressure is NOT exceeded.
- For heating floor system, air should be purged by means of an external pump and an open circuit to prevent the formation of air pockets.
- Check carefully for leaks in the water circuit, connections and circuit elements.

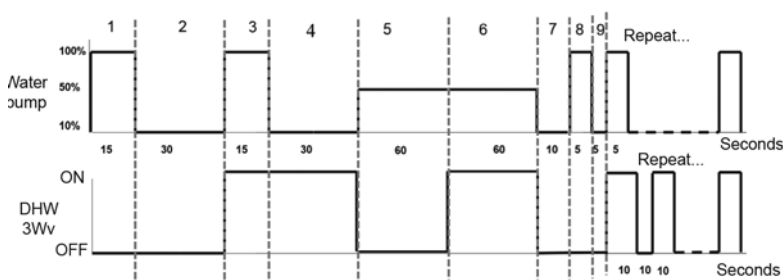

### 8.3 Minimum Water Volume Description

The following section shows how to calculate the minimum water volume in the system for product protection (anti-hunting) and temperature drop at defrosting.

- 1 Protective water volume for product. Ensure that the water volume is equal or greater than those shown below, in order to lower ON / OFF frequency of Enviroair unit at no load or extreme light load. When water volume is less than the volume indicated (minimum water volume), compressor operation frequently stops at light load, which should result in shorter life or failure.

#### **i** NOTE

The factory default ON / OFF temperature differential is "4 °C". Note that the minimum water volume varies for different setting for each purpose as shown in the next table (unit: ltrs.):

ON / OFF temperature differential	Model			
	Enviroair 7kW	Enviroair 11kW	Enviroair 14kW	Enviroair 16kW
4°C	28	38	46	56
3°C	36	48	58	70
2°C	50	65	80	96
1°C	80	107	130	156

- 2 Minimum required water volume during defrosting
  - The following formula is used to make the calculation:

Where: 
$$V = \frac{360 \times Q_{DEF}}{\Delta T \times 4168.8}; Q_{DEF} = Q_i + Q_y$$

V = Required water volume (m<sup>3</sup>)

The minimum volume of water needed in the installation to cover the heat loss caused by a reduction in the delivery water temperature during defrosting.

ΔT = Permissible water temperature drop (°C)

Drop in the delivery water temperature that the client is willing to allow in the installation.

Q<sub>DEF</sub> = Heat loss during defrosting (kW)

Heat loss caused in the system by reducing the delivery water temperature, which may affect the user's comfort level of warmth. This value is the sum of the two following items:

Q<sub>i</sub> = Heat demand from the installation (kW)

While defrosting is taking place, the unit is not providing the heat required to cover the heat demand from the installation.

This value can be obtained in 2 ways:

1. By using the value of the energy demand from the installation, if known.
2. If this value is not known, it can be estimated by using the heating capacity of the unit at an air temperature of 0°C WB and a delivery water temperature at, for example, 45°C.

Q<sub>Y</sub> = Cooling load on the Enviroair unit (kW)

In addition to not providing the heat required to cover the heat demanded by the installation during defrosting, the unit is also producing cold. It can be estimated that this value is approximately 85% of the heating capacity on the unit under standard conditions (air temperature: 6 / 7°C (WB/DB) and input / output temperature of the water: 40 / 45 °C).

#### **i** NOTE

The maximum time for defrosting considered is 6 minutes per hour.

The following table shows the minimum water volume needed in each Enviroair unit in case of a permitted drop in temperature of 10°C (unit: ltrs.).

Water temperature drop	Model			
	Enviroair 7.5kW	Enviroair 11kW	Enviroair 14kW	Enviroair 16kW
5°C	212	276	342	410
10°C	106	138	171	205
15°C	71	92	114	137
20°C	53	69	86	103
25°C	42	55	68	82

#### **i** NOTE

- The values shown on the table are based on theoretical installation conditions. In addition, Enviroair unit admits several hydraulic circuits configurations (as shown in the Manual of the system controller), and the value can be different depending on each specific installation.
- Therefore, it rests with the client to recalculate these values depending on the real conditions of the installation.

### 8.4 Water Control

It is necessary to analyse the quality of water by checking pH, electrical conductivity, ammonia ion content, sulphur content, and others. The following is the recommended standard water quality.

Item	Chilled water system		Tendency <sup>(1)</sup>	
	Circulating water (20 C less than)	Supply water	Corrosion	Deposits of scales
Standard quality pH (25 °C)	6.8 ~ 8.0	6.8 ~ 8.0	•	•
Electrical conductivity (mS/m) (25 °C) {μS/cm} (25 °C) <sup>(2)</sup>	Less than 40 Less than 400	Less than 30 Less than 300	•	•
Chlorine ion (mg Cl <sup>-</sup> /l)	Less than 50	Less than 50	•	
Sulphur acid ion (mg SO <sub>4</sub> <sup>2-</sup> /l)	Less than 50	Less than 50	•	
The amount of acid consumption (pH 4.8) (mg CaCO <sub>3</sub> /l)	Less than 50	Less than 50		•
Total hardness (mg CaCO <sub>3</sub> /l)	Less than 70	Less than 70		•
Calcium hardness (mg CaCO <sub>3</sub> /l)	Less than 50	Less than 50		•
Silica L (mg SiO <sub>2</sub> /l)	Less than 30	Less than 30		•
Reference quality Total iron (mg Fe/l)	Less than 1.0	Less than 0.3	•	•
Total copper (mg Cu/l)	Less than 1.0	Less than 0.1	•	
Sulphur ion (mg S <sup>2-</sup> /l)	It shall not be detected		•	
Ammonium ion (mg NH <sub>4</sub> <sup>+</sup> /l)	Less than 1.0	Less than 0.1	•	
Remaining chlorine (mg Cl/l)	Less than 0.3	Less than 0.3	•	
Floating carbonic acid (mg CO <sub>2</sub> /l)	Less than 4.0	Less than 4.0	•	
Index of stability	6.8 ~ 8.0	-	•	•

#### **i** NOTE

- (1) The mark “•” in the table means the factor concerned with the tendency of corrosion or deposits of scales.
- (2) The value showed in “{ }” are for reference only according to the former unit.

### 8.5 Water Piping Connection

#### Piping location and connection size

The unit is factory supplied with two unions to be connected to the water inlet / outlet pipe. Refer to the next figure detailing the location of the water pipes location, dimensions and connection sizes.

Description	Connection size
Water Inlet	Rp1”
Water Outlet	Rp1”

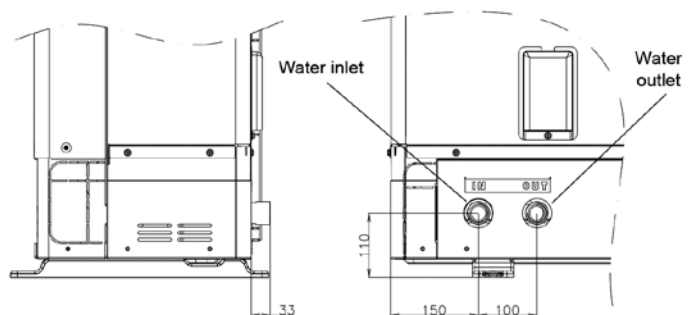

### 8.6 Suspension of Water Piping

Suspend the refrigerant and water piping at certain points and prevent the refrigerant and water piping from being in direct contact with the building: walls, ceilings, etc...

If there is direct contact between pipes, abnormal sound may occur due to the vibration of the piping. Pay special attention in cases of short piping lengths.

Do not fix the refrigerant and water pipes directly with the metal fittings (refrigerant piping may expand and contract).

Some examples for suspension method are shown opposite.

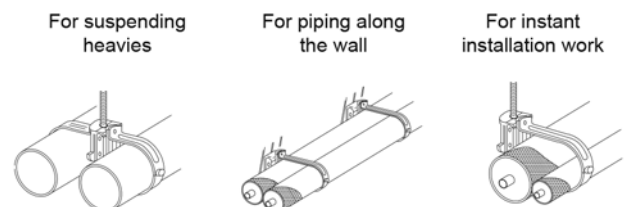

## 9. Electrical and Control Settings

### 9.1 General Check

- Make sure that the following conditions related to power supply installation are satisfied:
  - The power capacity of the electrical installation is large enough to support the power demand of the Enviroair system (outdoor unit + DHW tank (if apply)).
  - The power supply voltage is within  $\pm 10\%$  of the rated voltage.
  - The impedance of the power supply line is low enough to avoid any voltage drop of more than 15% of the rated voltage.
- Following the Council Directive 2004/108/EC, relating to electromagnetic compatibility, the table below indicates the maximum permitted system impedance  $Z_{max}$  at the interface point of the user's supply, in accordance with EN61000-3-11.

Model	Power supply	Operation mode	$Z_{max}$ ( $\Omega$ )
Enviroair 7kW	1- 230V 50Hz	-	0.35
		With DHW tank heater	0.22
Enviroair 11kW		-	0.24
		With DHW tank heater	0.17
Enviroair 14kW		-	0.24
		With DHW tank heater	0.17
Enviroair 16kW		-	0.24
		With DHW tank heater	0.17
Enviroair 11kW	3N- 400V 50Hz	-	-
		With DHW tank heater	0.31
Enviroair 14kW		-	-
		With DHW tank heater	0.31
Enviroair 16kW		-	-
		With DHW tank heater	0.30

#### NOTE

The data corresponding to DHW tank heater is calculated in combination with the Firebird domestic hot water tank accessory.

- The status of Harmonics for each model, regarding compliance with IEC 61000-3-2 and IEC 61000-3-12, is as follows:

Status regarding compliance with IEC 61000-3-2 and IEC 61000-3-12	Models
Equipment complying with IEC 61000-3-2 (*): Professional use	Enviroair 7.5kW Enviroair 11kW Enviroair 14kW Enviroair 16kW
Equipment complying with IEC 61000-3-12	-
Installation restrictions may be applied by supply authorities in relation to harmonics	-

- Check to ensure that existing installation (mains power switches, circuit breakers, wires, connectors and wire terminals) already complies with the national and local regulations.
- The use of the DHW tank heater is disabled as factory setting. If it is desired to enable the DHW tank heater operation during normal unit operation, adjust the DSW4 pin 3 of the PCB1 to the ON position and use the adequate protections.

## 9.2 Electrical Wiring Connection for Outdoor Units

The electrical wiring connection for the outdoor unit is shown in figure below

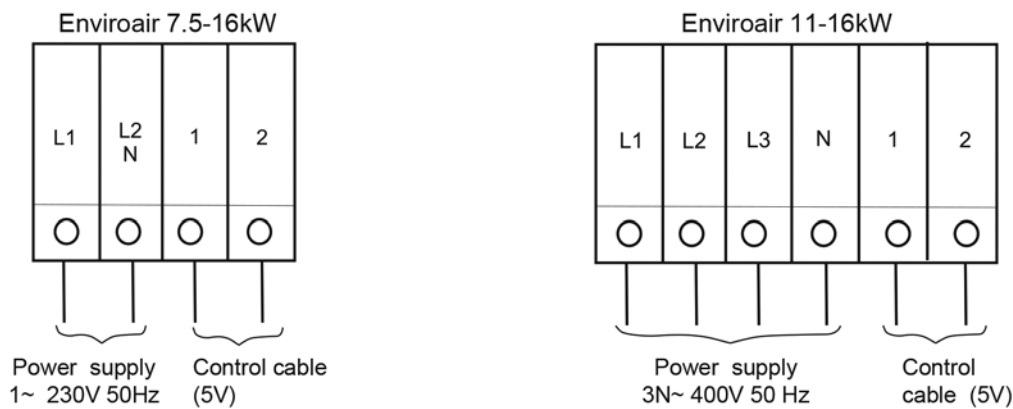

### 9.2.1 Power and transmission wiring connection

#### Safety instructions

#### **i** NOTE

Check the requirements and recommendations in the chapter "9 ELECTRICAL AND CONTROL SETTINGS".

#### **!** DANGER

- Do not connect the power supply to the unit prior to filling the space heating circuit (and DHW circuit if it were the case) with water and checking water pressure and the total absence of any water leakage.
- Do not connect or adjust any wiring or connections unless the main power switch is OFF.
- When using more than one power source, check and ensure that all of them are turned OFF before operating the unit.
- Avoid wiring installation in contact with the refrigerant pipes, water pipes, edges of plates and electrical components inside the unit to prevent damage, which may cause electric shock or short circuit.

#### **!** CAUTION

- Use a dedicated power circuit for the unit. Do not use a power circuit shared with the outdoor unit or any other appliance.
- Make sure that all wiring and protection devices are properly selected, connected, identified and fixed to the corresponding terminals of the unit, especially the protection (earth) and power wiring, taking into account the applicable national and local regulations. Establish proper earthing; Incomplete earthing may cause electrical shock.
- Protect the unit against the entry of small animals (like rodents) which could damage the drain pipe and any internal wire or any other electrical part, leading to electric shock or short-circuit.
- Keep a distance between each wiring terminal and attach insulation tape or sleeve as shown in the figure.

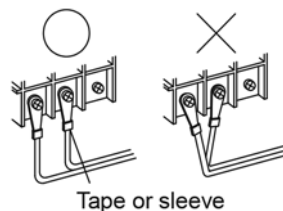

### 9.3 Wiring Size and Minimum Requirements of the Protection Devices

#### CAUTION

- Check to ensure that the field supplied electrical components (mains power switches, circuit breakers, wires, connectors and wire terminals) have been properly selected according to the electrical data indicated on this chapter and they comply with national and local codes. If it is necessary, contact with your local authority in regards to standards, rules, regulations, etc.
- Use a dedicated power circuit for the unit. Do not use a power circuit shared with the outdoor unit or any other appliance.

Use wires which are not lighter than the polychloroprene sheathed flexible cord (code designation 60245 IEC 57).

Model	Power supply	Operation mode	Max. current (A)	Power supply cables	Transmitting cables	CB (A)	ELB (No of poles/A/mA)
				EN60335-1	EN60335-1		
Enviroair 7.5kW	1- 230V 50Hz	-	22	2 x 6.0 mm <sup>2</sup> + GND	2 x 0.75 mm <sup>2</sup>	25	2/40/30
		With DHW tank heater	34	2 x 10.0 mm <sup>2</sup> + GND		40	
-		31	2 x 6.0 mm <sup>2</sup> + GND	32			
Enviroair 11kW		With DHW tank heater	43	2 x 10.0 mm <sup>2</sup> + GND		50	2/63/30
		-	31	2 x 6.0 mm <sup>2</sup> + GND		32	2/40/30
Enviroair 14kW		With DHW tank heater	43	2 x 10.0 mm <sup>2</sup> + GND		50	2/63/30
		-	31	2 x 6.0 mm <sup>2</sup> + GND		32	2/40/30
Enviroair 16kW		With DHW tank heater	43	2 x 10.0 mm <sup>2</sup> + GND		50	2/63/30
		-	31	2 x 6.0 mm <sup>2</sup> + GND		32	2/40/30
Enviroair 11kW		3N- 400V 50Hz	-	14		4 x 4.0 mm <sup>2</sup> + GND	20
	With DHW tank heater		27	4 x 6.0 mm <sup>2</sup> + GND	30		
-	14		4 x 4.0 mm <sup>2</sup> + GND	20			
Enviroair 14kW	With DHW tank heater		27	4 x 6.0 mm <sup>2</sup> + GND	30		
	-		16	4 x 6.0 mm <sup>2</sup> + GND	20		
Enviroair 16kW	With DHW tank heater		29	4 x 10.0 mm <sup>2</sup> + GND	40		

#### NOTE

The data corresponding to DHW tank heater is calculated in combination with the Firebird domestic hot water tank accessory.

#### CAUTION

- Ensure specifically that there is an Earth Leakage Breaker (ELB) installed for the units (outdoor unit).
- If the installation is already equipped with an Earth Leakage Breaker (ELB), ensure that its rated current is large enough to hold the current of the units (outdoor unit).

#### NOTE

- Electric fuses can be used instead of magnetic Circuit Breakers (CB). In that case, select fuses with similar rated values as the CB.
- The Earth Leakage Breaker (ELB) mentioned on this manual is also commonly known as Residual Current Device (RCD) or Residual Current Circuit Breaker (RCCB).
- The Circuit Breakers (CB) are also known as Thermal-Magnetic Circuit Breakers or just Magnetic Circuit Breakers (MCB).

## 9.4 Optional Unit Wiring (Accessories)

### Summary of the terminal board connections



Mark	Part name	Description
Terminal board 2 (TB2)		
1	H-LINK commutation	The H-LINK transmission has to be done between the unit and the terminals 1-2 of either outdoor unit, ATW-RTU-05 or any other central device
2		
3	H-LINK communication for remote control switch	Terminals for the connection of the Enviroair unit controller
4		
5	DHW tank's thermistor	The DHW sensor is used to control the temperature of the domestic hot water tank
6	Common thermistor	Common terminal for thermistor
7	Thermistor for water outlet temperature of second cycle	The sensor is used for the second temperature control and should be positioned after the mixing valve and the circulation pump
8	Thermistor for water outlet temperature after hydraulic separator	Water sensor for hydraulic separator, buffer tank or boiler combination
9	Common thermistor	Common terminal for thermistors
10	Thermistor for swimming pool water temperature	The sensor is used for the swimming pool temperature control and should be positioned inside plate heat exchanger of the swimming pool
11	Thermistor for second ambient temperature	The sensor is used for the second ambient temperature control and it should be positioned outdoors
11	4-20 mA application	It is possible to connect an external controller to the connector CN5 to provide a manual water temperature setting. The input current (4-20 mA) will be transformed into voltage by means of a grounded 240 Ω resistor connected to these terminals. The DSW5 pin 3 must be in ON position 12 and the SSW1 has to be in local mode (enabled manual operation) to enable this function
12		
13	Common line	Terminal line common for input 1 and input 2
14	Input 1 (Demand ON / OFF) (*)	The air to water heat pump system has been designed to allow the connection of a remote thermostat to effectively control your home's temperature. Depending on the room temperature, the thermostat will turn the split air to water heat pump system ON and OFF
15	Input 2 (ECO mode) (*)	Available signal which allows to reduce the water setting temperature of circuit 1, circuit 2 or both
16	Common line	Terminal Line common for inputs 3, 4, 5, 6, 7
17	Input 3 (Swimming pool) (*)	Only for swimming pool installations: It is necessary to connect an external input to the air to water heat pump to provide signal when the water pump of swimming pool is ON
18	Input 4 (Solar) (*)	Available input for solar combination with domestic hot water tank
19	Input 5 (Smart function) (*)	For the connection of an external tariff switch device to switch OFF the heat pump during peak electricity demand period. Depending on the setting, the heat pump or DHWT will be blocked when signal is open / closed
20	Input 6 (DHW boost) (*)	Available input for an instantaneous heating of the domestic hot water of the tank
21	Input 7 (Power meter)	The measuring of the real power consumption can be done connecting an external power meter. The number of pulses of the power meter is a variable which must be set. By this, every pulse input is added into corresponding operation mode (heating, cooling, DHW operation). Two possible options: - One power meter for all installation (IU+OU). - Two separated power meters (one for IU and one for OU)
22	Aquistat security for circuit 1 (WPI)	Terminals intended for the connection of the Aquistat security accessory (ATW-AQT-01) for controlling water temperature of the circuit 1
23		
24 (C)	Mixing valve close	When a mixing system is required for a second temperature control, these outputs are necessary to control the mixing valve
25 (O)	Mixing valve open	
26 (N)	N Common	

**Summary of the terminal board connections (cont.)**

Mark	Part name	Description
27 (L)	Water Pump 2 (WP2)	When there is a second temperature application, a secondary pump is the circulating pump for the secondary heating circuit
28	Aquastat security for circuit 2 (WP2)	Terminals intended for the connection of the Aquastat security accessory for controlling water temperature of the circuit 2
29		
30 (N)	Electrical Heater DHW Output	If DHW tank contains an electric heater, the air to water heat pump can activate it if the heat pump cannot achieve the required DHW temperature by itself
31 (L)		
32 (C)	Common line	Common terminal for the 3-way valve for DHW tank
33 (L)	3-way valve for DHW tank	The air to water heat pump can be used to heat DHW. This output will be on when DHW is activated
34 (N)	N common	Neutral terminal common for 3-way valve of DHW tank and outputs 1 and 2
35 (L)	Output 1 (3-way valve for swimming pool) (*)	The air to water heat pump can be use to heat swimming pool. This output will be ON when swimming pool is activated
36 (L)	Output 2 (Water pump 3 (WP3) (*)	When there is a hydraulic separator or buffer tank, additional water pump (WP3) is needed
37	Output 3 (Auxiliary boiler or electric heater) (*)	The boiler can be used to alternate with the heat pump when the heat pump cannot achieve the required temperature by itself
38		A water electric heater (as accessory) can be used to provide the additional heating required on the coldest days of the year
39	Output 4 (Solar) (*)	Output for solar combination with domestic hot water tank
40		

**NOTE**

(\*): Inputs and outputs explained in the table are the factory-set options. By means of the unit controller, some other inputs and outputs functions can be configured and used. Please contact Firebird for further information.

**9.5 Setting of Dip Switches and RSW Switches**

**9.5.1 Setting of DIP switches for IPM-PCB**

3HP		4HP 5HP 6HP	
-----	---	-------------------	---

**NOTE**

If deemed necessary, the engineer should change the dip switches on the right-hand board only.

**9.5.2 Setting of DIP switches for PCB1**

**Quantity and position of DIP switches**

**PCB1**

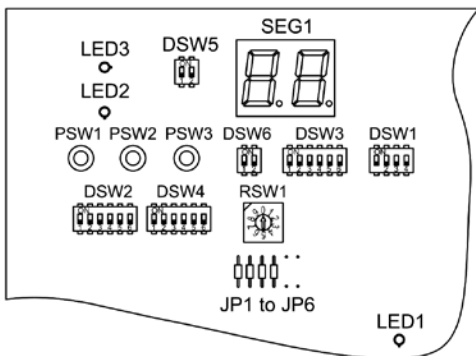



**DSW1: For test run**

Factory setting	
-----------------	---

**DSW2**

Factory setting	
-----------------	--

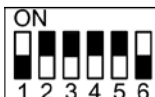
**DSW3: Capacity**

Enviroair 7.5kW		
Enviroair 11kW	Enviroair 14kW	Enviroair 16kW
		

9.5.2 Setting of DIP switches for PCB1 (cont.)

DSW4 / RSW1

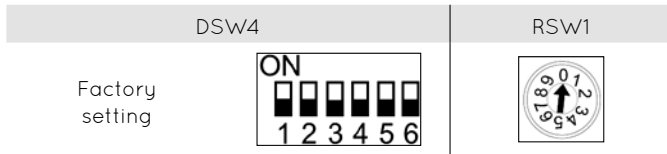

DSW5

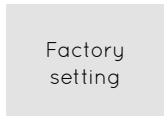

DSW6

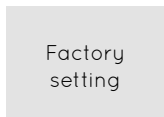

Function of DIP switches and rotary switches

**i** NOTE

- The mark “” indicates the dip switches positions.
- No mark “” indicates pin position is not affected.
- The figures show the settings before shipment or after selection.
- “Not used” means that the pin must not be changed. A malfunction might occur if changed.

**!** CAUTION

Before setting dip switches, first turn the power supply OFF and then set the position of dip switches. If the switches are set without turning the power supply OFF, the contents of the setting are invalid.

DSW1: Additional setting 0

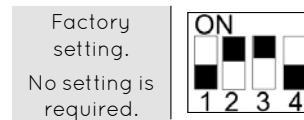

9.5.3 Location of DIP switches and rotary switches

PCB2

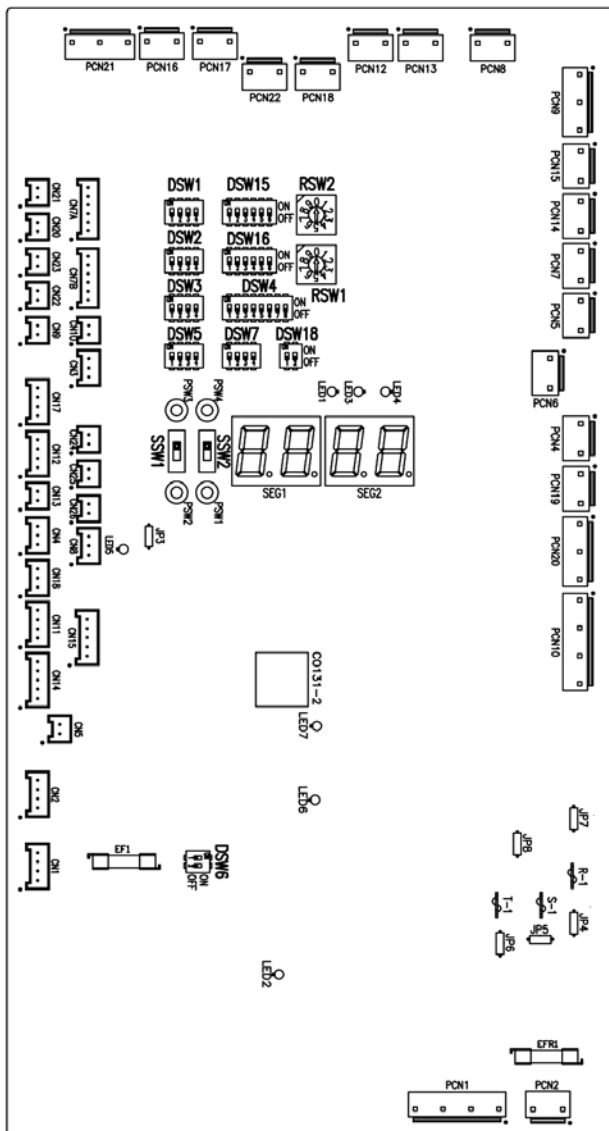

**i** NOTE

In case of installing the “cooling kit” accessory, set the pin 4 of DSW1 to ON in order to enable the cooling operation.

DSW2: Unit capacity setting

No setting is required.

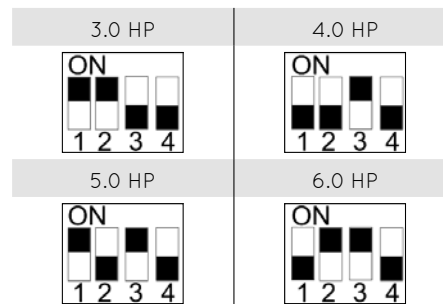

DSW3: Additional setting 1

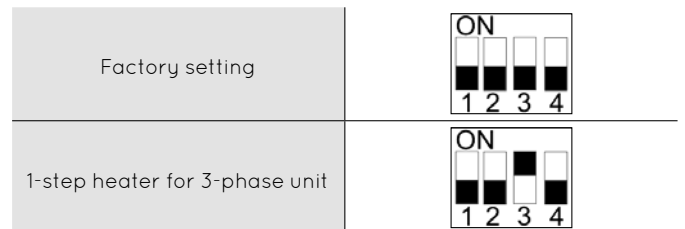

DSW4: Additional setting 2

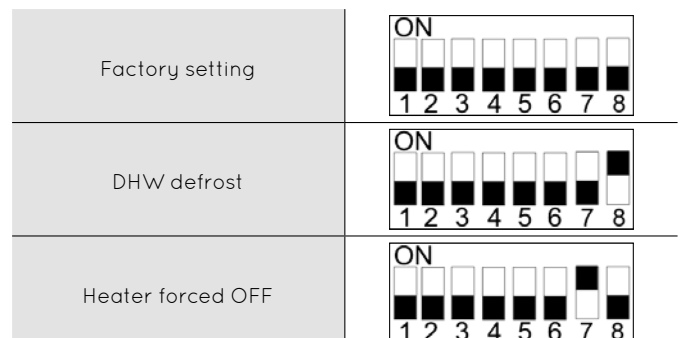

**9.5.3 Location of DIP switches and rotary switches (cont.)**

Unit and installation pipes antifreeze protection	
Standard / ECO water pump operation	
Electric heater or boiler emergency mode	
DHW tank's heater operation	
DHW 3-way valve forced ON	

**CAUTION**

- Never turn all DSW4 dip switch pins ON. If this happens, the software of the unit will be removed.
- Never activate "Heater Forced OFF" and "Electric heater or boiler emergency mode" at the same time.

**DSW5: Additional setting 3**

In the cases where the outdoor unit is installed into a location where its own outdoor ambient temperature sensor can not give a suitable temperature measurement to the system, it is available the 2nd outdoor ambient temperature sensor as accessory. By means of DSW1&2 setting, the preferable sensor for each circuit can be selected.

Factory setting	
Outdoor unit sensor for circuits 1 and 2	
Outdoor unit sensor for circuit 1; Auxiliary sensor for circuit 2	
Auxiliary sensor for circuit 1; Outdoor unit sensor for circuit 2	
Auxiliary sensor instead of outdoor unit sensor for both circuits	
4-20 mA setting temperature (only manual operation)	
Use the maximum temperature value between Two3 (boiler / heater thermistor) and Two (water outlet thermistor) for water control	

**DSW6: Not used**

Factory setting (do not change)	
---------------------------------	--

**DSW7: Additional setting 4**

Factory setting	
Defrost for the water electric heater	

**DSW18: Not used**

Factory setting (do not change)	
---------------------------------	--

**DSW15 & RSW2 / DSW16 & RSW1: not used**

Factory setting (do not change)		
---------------------------------	--	--

**SSW1: Remote / local**

Factory setting (remote operation)	
Local operation	

**SSW2: Heat / cool**

Factory setting (heat operation)	
Cool and heat operation in case of Local	

**9.5.4 LED indication**

Name	Colour	Indication
LED1	Green	Power indication
LED2	Red	Power indication
LED3	Red	Heat pump operation (thermo ON / OFF)
LED4	Yellow	Alarm (flickering with 1 sec interval)
LED5	Green	Not used
LED6	Yellow	H-Link transmission
LED7	Yellow	H-Link transmission for unit controller

## 10. Commissioning

### 10.1 Before Operation

#### CAUTION

- Supply electrical power to the system for approximately 12 hours before start-up after a long shut-off. Do not start the system immediately after power supply, it may cause compressor failure because the compressor is not well-heated.
- When the system is started after a shut-off longer than approximately 3 months, it is recommended that the system be checked by your service contractor.
- Turn OFF the main switch when the system is to be stopped for a long period of time: as the oil heater is always energised even when the compressor is not working, there will be electricity consumption unless the main switch is turned OFF.

### 10.2 Preliminary Check

When installation is complete, perform commissioning according to the following procedure, and hand over the system to the customer. Perform the commissioning of the units methodically, and check that the electrical wiring and the piping are correctly connected.

Enviroair units must be configured by the installer to get the perfect setting and the unit working.

#### 10.2.1 Checking the unit

- Check external appearance of the unit to look for any damage due to transportation or installation.
- Check that all the covers are totally closed.
- Check that the recommended service space is respected (see "5.1 Service space").
- Check that the unit has been correctly installed.

#### 10.2.2 Electrical checking

#### CAUTION

Do not operate the system until all the check points have been cleared:

- Check to ensure that the electrical resistance is more than 1 M $\Omega$ , by measuring the resistance between ground and electrical parts terminal. If not, do not operate the system until the electrical leakage is found and repaired. Do not impress the voltage on the terminals for transmission and sensors .
- Check to ensure that the switch on the main power source has been ON for more than 12 hours, in order to give the oil heater time to warm the compressor.
- In three-phase unit check phase sequence connection on terminal board.
- Check the power supply voltage ( $\pm 10\%$  of the rated voltage).
- Check that field-supplied electrical components (main switches, breakers, wires, conduit connectors and wire terminals) have been properly selected according to the electrical specifications given in this document, and check that the components comply with national and local standards.
- Do not touch any electrical components for more than three minutes after turning OFF the main switch
- Check the dip switch settings of the unit are connected as shown in the corresponding chapter.
- Check to ensure the electrical wiring of the unit is connected as shown in the chapter.
- Check to ensure the external wiring is correctly fixed. To avoid problems with vibrations, noises and cut out wires with the plates.

#### 10.2.3 Hydraulic circuit checking (space heating and DHW)

- Check that the circuit has been properly flushed and filled with water and that the installation has been drained: the pressure of the heating circuit must be 1.8 bar
- Check for any leakage in water cycle. Pay special attention to the water piping connections.
- Make sure the system's internal water volume is correct.
- Check that the hydraulic circuit's valves are fully open.
- Check to see that electrical heater is completely filled with water by operating pressure of safety valve.
- Check to see that additional water pumps (WP2 or / and WP3) are correctly connected to terminal board.

#### CAUTION

- Operating the system with closed valves will damage the unit.
- Check to see that air purge valve is open and that the hydraulic circuit is air purged. The installer is responsible of completely air purging the installation.
- Check that the water pump of the space heating circuit works within the pump operating range and that the water flow is over the pump's minimum. If the water flow is under 12 litres / minute (6 litres / minute for 7.5kW unit) (with flow switch tolerance), alarm will be displayed on the unit.
- Remember that water connection must be accordance with local regulations.
- Water quality must comply with EU directive 98/83 EC.
- Electrical heater operation when not completely filled with water will damage the heater.

### 10.2.4 Checking the refrigerant circuit

- Check to ensure that the stop valves on the gas and liquid lines are fully open.
- Check the inside of the unit for refrigerant leakage. If there is a refrigerant leak, please contact Firebird.
- Do not touch any of the parts by hand at the discharge gas side, since the compressor chamber and the pipes at the discharge side are heated higher than 90°C.
- DO NOT PUSH THE BUTTON OF THE MAGNETIC SWITCH(ES), it will cause a serious accident.
- Confirm that the leakage of the refrigerant does not exist. The flare nuts are sometimes loosened by vibration during transportation

### 10.2.5 Test and check

Finally, test and check the following items:

- Water leakage
- Refrigerant leakage
- Electrical connection

## 10.3 Commissioning Procedure

This procedure is valid regardless of what options are on the module.

- When installation is complete and all necessary settings (dip-switches in PCBs and user controller configuration) have been carried out, close the electrical box and place the cabinet as shown in the manual.
- Make the start-up wizard configuration in the user controller.
- Make a test run as shown in item “10.4 Test run / air purge”.
- After test run is completed, start the entire unit or the selected circuit by pressing the OK button.

### Initial start-up at low outdoor ambient temperatures

During commissioning and when water temperature is very low, it is important for the water to be heated gradually. Additional optional function can be used for starting at low water temperature conditions: Screed drying function:

- The screed function is used exclusively for the process of drying a newly applied screed to the floor heating system.
- The process is based on EN-1264 part 4.
- When user activates screed function, the water set point follows a predetermined schedule:
  - 1 Water set point is kept constant at 25°C for 3 days
  - 2 Water set-point is set to the maximum heating supply temperature (but always limited to ≤55°C) for 4 days.

### ⚠ CAUTION

- Heating at lower water temperatures (approximately 10°C to 15°C) and lower outdoor ambient temperatures (<10°C) can be damaging to the heat pump when defrosting.
- As a result, Heating up to 15°C when outdoor temperature is lower than 10°C is performed by the Electrical Heater.

### ℹ NOTE

*In case of Heater Forced OFF (by optional dip switch setting) these condition is not performed and heating is performed by Heat Pump. Firebird is not responsible for its operation.*

### ⚠ CAUTION

It is recommended to start the unit (first power ON) with heater forced OFF and compressor forced OFF (see “9.5 Setting of DIP switches and RSW switches”). In order to circulate water by water pump and remove possible air into the heater (check heater completely filled).

## 10.4 Test Run / Air Purge

Test run is a working mode used when commissioning the installation. Air purge function drives the pump in a way for evacuating air bubbles in the installation.

A menu with specific function for commissioning appears by pressing the menu+back buttons for 3 seconds at the installer menu (OK+back buttons).

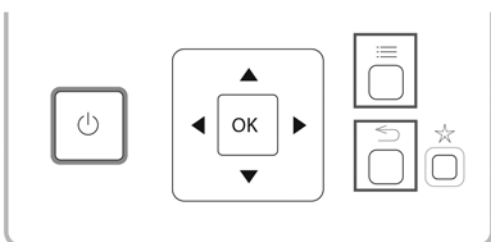

This menu shows the following test to be launched:

- Unit test run
- Air purge
- Screed drying

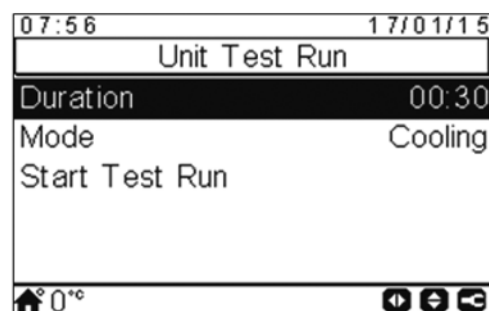

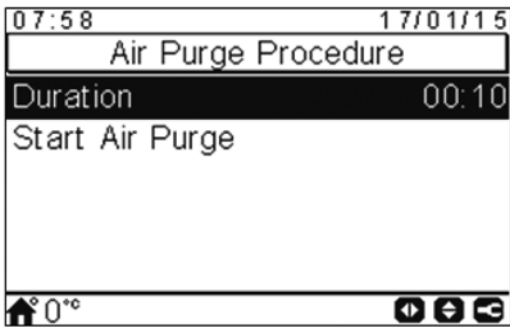

After “Test Run” or “Air Purge” option is selected, the Enviroair user controller asks for the duration of the test.

In case of test run, user can also select the mode of the test (cooling or heating).

When user confirms the test run or the air purge, the Enviroair user controller sends the order to the unit.

During the execution of this test, the following screen is shown:

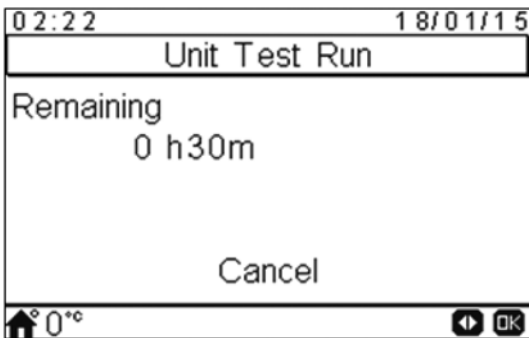

- When the test starts, the user controller will exit from the installer mode.
- If “favourite action button” is pressed during test run, this function will be executed until the user presses the cancel option (this is not-limited by time).
- User can cancel the test run regardless of the time left for test finishing.
- The Test Run icon is shown in the notifications zone, but the notification of this test run is taken from H-LINK.

When test run has finished, an information message is displayed in the screen, and pressing accept, the user returns to the global view.

### **i** NOTE

- *When commissioning and installing the unit, it is very important to use the “Air purge” function to remove all the air in the water circuit. When the air purge function is running, the water pump starts the automatic air venting routine which consists of regulating the speed and open / close configured 3-way valve to help to evacuate air from the system.*
- *If there is a heater or a boiler installed, disable the operation before running the test run.*

## 11. Unit Controller

### 11.1 Definition of the Switches

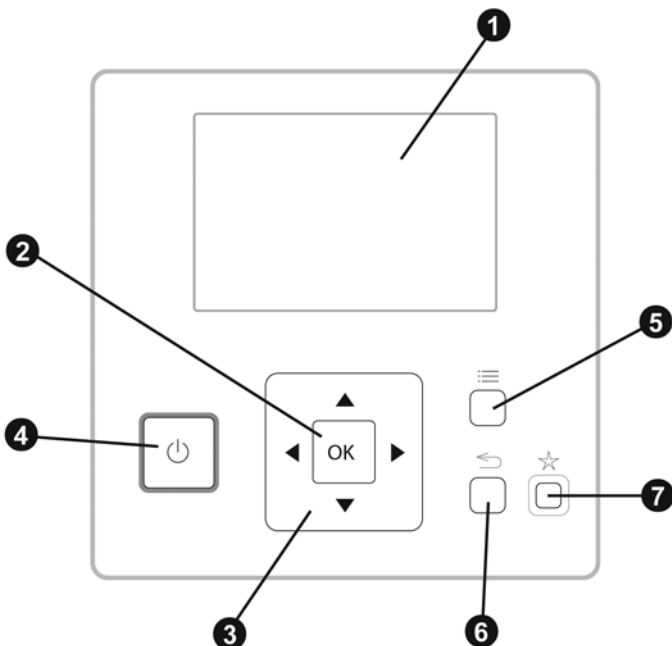

- 1 Liquid crystal display**  
Screen where controller software is displayed.
- 2 OK button**  
To select the variables to be edited and to confirm the selected values.
- 3 Arrows key**  
It helps the user to move through the menus and views.
- 4 Run / stop button**  
It works for all zones if none of the zones are selected or only for one zone when that zone is selected.
- 5 Menu button**  
It shows the different configuration options of the user controller.
- 6 Return button**  
To return to the previous screen.
- 7 Favourite button**  
When this button is pressed, the selected favourite action (ECO / comfort, holiday, simple timer or DHW boost) is directly executed.

## 11.2 Main Screen

Depending on the working mode of the user controller, the main screen is shown in a different way. When the user controller is working as a master unit controller, a comprehensive view with all the elements is shown, whereas when the user controller is working as a room thermostat (located in one of the controlled zones), the main screen appears with simplified information.

### 11.2.1 Comprehensive view

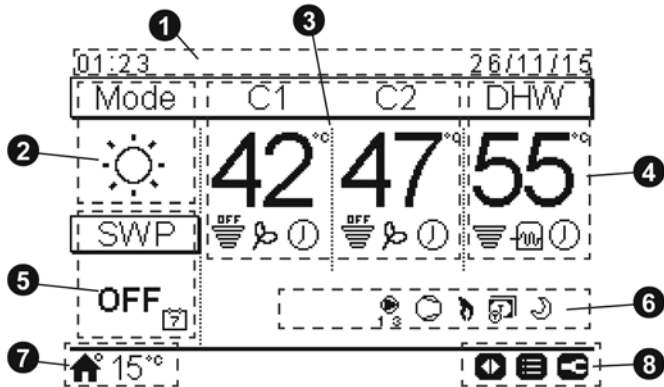

#### 1 Time and date

The current time / date information is displayed. This information can be changed on the configuration menu.

#### 2 Operation mode (heating / cooling / auto)

This icon shows the unit's mode of operation status. It has to be edited by pressing the OK button, and it can be switched between heating, cooling and auto mode (if enabled option).

#### 3 Control of circuits 1 and 2

It displays the setting temperature calculated for each circuit and a throughput icon indicating the percentage of the actual temperature with respect to the setting temperature. It can also show the ECO mode and timer activation if they are enabled.

The setting temperature can be modified using the arrows keys over this view (if Water calculation mode is set as "Fix").

Pressing the OK button, the following options are shown:

- Timer: In this menu, simple timer or schedule timer can be selected and configured.
- OTC: OTC setting temperature (user can only refer to the OTC mode and its setting temperature value)
- Comfort / ECO: Selection between comfort and ECO mode.
- Status: Some working conditions can be consulted.

#### 4 DHW control

It displays the setting temperature calculated for DHW and a throughput icon indicating the percentage of the actual temperature with respect to the setting temperature. It can also show the operation of the electrical heater of the DHW, the timer activation and the DHW boost if they are enabled.

The setting temperature can be modified using the arrows keys over this view.

Pressing the OK button, the following options are shown:

- Timer: In this menu, simple timer or schedule timer can be selected and configured.
- DHW boost: It activates the DHW heater for an immediate DHW operation
- Status: Some working conditions can be consulted.

If anti-legionella operation is working, its icon appears below the setting temperature.

#### 5 Swimming pool control

It gives information about the swimming pool setting temperature and displays a throughput icon indicating the percentage of the actual temperature with respect to the setting temperature.

The setting temperature can be modified using the arrows keys over this view.

Pressing the OK button, the following options are shown:

- Timer: In this menu, simple timer or schedule timer can be selected and configured.
- Status: Some working conditions can be consulted.

#### 6 Unit status signals

This part of the screen displays all the notification icons that offer general knowledge on the unit's situation.

Some of these icons can be: defrost operation, water pumps, compressor/s, boiler working, tariff input, test run, night shift...

#### 7 Outdoor temperature / alarm indication

In normal operation, the outdoor temperature is displayed besides the home icon signal.

In abnormal operation, the alarm icon is indicated with its corresponding alarm code.























#### 8 Available buttons / installer mode

It indicates the buttons of the user controller which can be used in that moment.





























When installer mode is enabled, its icon appears on the right side of this view.

### 11.3 Description of the Icons

#### 11.3.1 Common icons

Icon	Name	Values	Explanation
OFF			Circuit I or II is in demand-OFF
	Status for circuit 1, 2, DHW and swimming pool		Circuit I or II is on thermo-OFF
			Circuit I or II is working between $0 < X \leq 33\%$ of the desired water outlet temperature
			Circuit I or II is working between $33 < X \leq 66\%$ of the desired water outlet temperature
			Circuit I or II is working between $66 < X \leq 100\%$ of the desired water outlet temperature
	Mode		Heating
			Cooling
			Auto
88	Setting temps	Value	Displays the setting temperature of the circuit 1, circuit 2, DHW and swimming pool
		OFF	Circuit 1, Circuit 2, DHW or swimming pool are stopped by button or timer
	Alarm		Existing alarm. This icon appears with the alarm code
	Timer		Simple timer
			Weekly timer
	Derogation		When there is a derogation from the configured timer
	Installer mode		Informs that user controller is logged on the installer mode which has special privileges
	Menu lock		It appears when menu is blocked from a central control. When communication is lost, this icon disappears
	Outdoor temperature		The ambient temperature is indicated at the right side of this button

#### 11.3.2 Icons for the comprehensive view

Icon	Name	Values	Explanation
	Pump		This icon informs about pump operation.
			There are three available pumps on the system. Each one is numbered, and its corresponding number is displayed below to the pump icon when it is operating
	Heater step		Indicates which of the 3 possible heater steps is applied on space heating
	DHW heater		Informs about DHW Heater operation (if it is enabled)
	Solar		Combination with solar energy
	Compressor		Compressor enabled
	Boiler		Auxiliary boiler is working
	Tariff		Tariff signal informs about some cost conditions of the consumption of the system
	Defrost		Defrost function is active
	Central / local	-	No icon means local mode
			Central mode (Three types of control: water, air or full)
	Forced OFF		When forced off Input is configured and its signal is received, all the configured items on the comprehensive view (C1, C2, DHW, and / or SWP) are shown in OFF, with this small icon below
	Auto ON / OFF		When daily average is over auto summer switch-off temperature, circuits 1 & 2 are forced to OFF (only if Auto ON / OFF enabled)
<b>TEST RUN</b>	Test run	<b>TEST RUN</b>	Informs about the activation of the "test run" function
<b>ANTI LEG</b>	Anti-legionella	<b>ANTI LEG</b>	Activation of the anti-legionella operation
	DHW boost		It activates the DHW heater for an immediate DHW operation
	ECO / comfort mode for circuits 1 & 2	-	No icon means comfort mode
			ECO mode
	Night shift		Informs about night shift operation

### 11.4 Unit Controller Wizard Set-Up

The wizard set-up has to be done from the main controller.



- Select language required.
- Press OK.



- Use arrow keys to set correct time and date.
- Press OK.



- Press OK to use configuration assistant (Wizard).



- This will always be Yes.
- Press OK.



- If this controller is also to be used as a thermostat, select Yes.
- Otherwise select No.
- Press OK.

- If you have two different temperature circuits (i.e. Radiators and Underfloor Heating) - select 2.
- If you only have one heating circuit - select 1.
- Press OK.



- Use arrows to select Radiators, Fan Coils or Underfloor.
- Repeat step above if you have a second circuit.
- Press OK.

- If Domestic Hot Water is required, select Yes.
- Press OK.



- Select No, if no swimming pool heating required.
- Press OK.



- Select No, if no boiler installed.\*
- Press OK.

*\* If boiler installed, please refer to "14. Hybrid Systems".*



- Select No, if Monovalent System
- Select Yes, if Bivalent System
- Press OK.



- If selected Yes, set the Bivalent point for the boiler to be enabled. Recommended setting is -5°C.
- Press OK.

The next screen will ask “How many Room Thermostats are installed?”

This relates only to Firebird thermostats. If no Firebird thermostats are installed, select 0. Press OK.

(You will then move to the last screen). If Firebird thermostats are installed. Select how many (1 or 2). Press OK.



- Use arrows to select wired or wireless.
- Press OK.
- Repeat step above if you have a 2nd Zone.
- Press OK.

- Wizard set up is complete.
- Press OK to go to home screen.

To access Installer menu:

 Press and hold OK and return buttons together for 3 seconds.

'Password' will then appear on the screen.

Press:

 Then press 'OK'

Password correct will then appear.

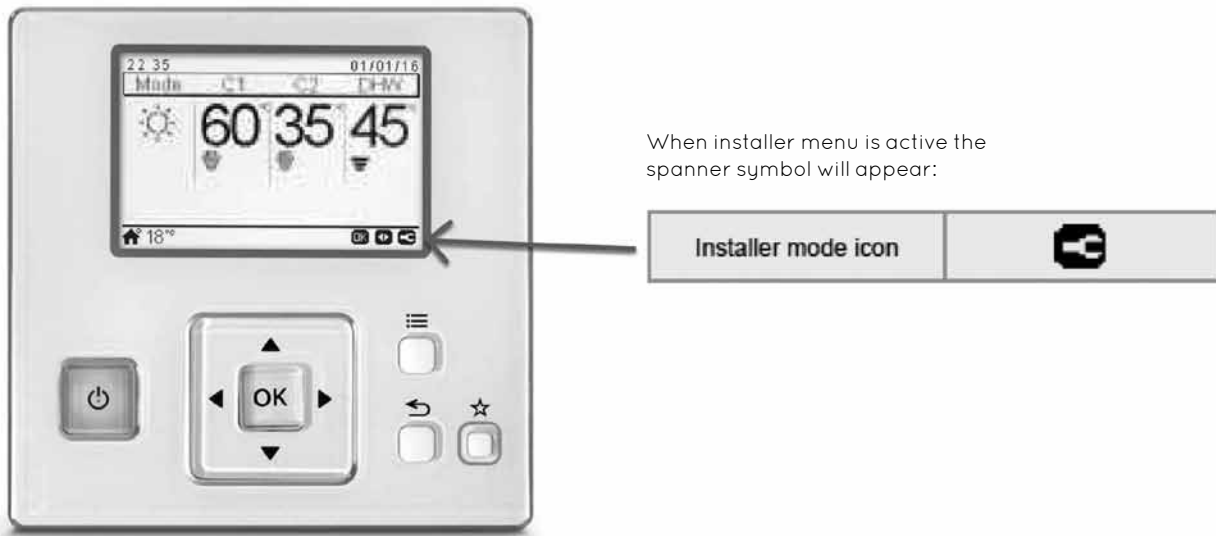

Below is a guide to navigate through the controller. Once any changes have been made press return button to escape back to the home screen. (Activate Installer menu first).

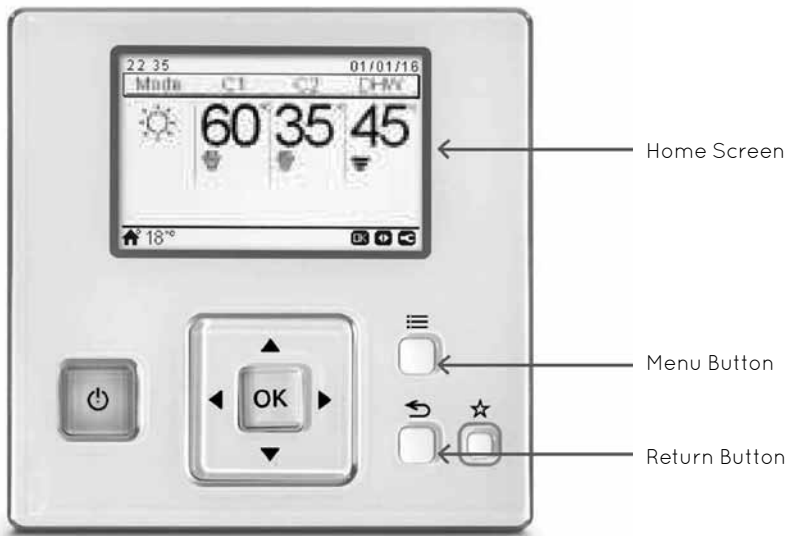

### Air Purge Procedure

- Press Menu
- Scroll to Commissioning – OK
- Air Purge Procedure – OK
- Set duration – Up to 12 Hours
- Select Start Air Purge – OK
- Select Yes – OK
- Select Cancel – OK to stop Air Purge procedure.

### Activate Anti-legionella

- Press Menu
- System Configuration – OK
- Scroll to DHW – OK
- Scroll down to Anti-Legionella – OK
- Change status from disabled to enabled
- Set parameters to suit.

### Set Heating Mode – Gradient / Fixed or Points

- Press Menu
- System Configuration – OK
- Space Heating – OK
- Circuit 1 – OK
- Water Calculation Mode – OK
- Select Gradient (Weather Comp) Fixed or Points (Manual Gradient)
- Push Down to Gradient
- Push left arrow to decrease or right arrow to increase.

### Set Maximum and Minimum Temperatures for Heating System

- Press Menu
- System Configuration – OK
- Space Heating – OK
- Working Limits – OK
- Change Maximum and Minimum Temperatures to suit.

### Activate Heating Sensor

- Press Menu
- System Configuration – OK
- I/O and Sensor – OK
- Auxiliary Sensors – OK
- Sensor 1 – (Press right arrow) change from Disabled to Two3

### Activate Buffer / Pump after Buffer

- Press Menu
- System Configuration – OK
- Optional Functions – OK
- System – OK
- Hydraulic Separator Status – change to enabled.

### Activate Favourite Button – DHW Boost

(Immersion Heater has to be enabled first – DSW 4, Pin 3 on)

- Menu
- Controller settings – OK
- Controllers Options – OK
- Favourite Action – Change to DHW Boost
- Press return back to home screen.

### Press Menu

- System Configuration – OK
- Optional Functions – OK
- Scroll to DHW – OK
- DHW Boost – Set to PUSH
- Boost Setting – Set to 50°C.

### Stop Pumps running when there is no demand

DSW 4, Pin 5 needs to set- pushed up

- Press Menu
- System Configuration – OK
- Scroll to Heat Pump – OK
- Water Pump Configuration – OK
- Minimum off time – Change to 0 mins
- Minimum on time – change to 0 mins
- Overrun time – change to 0 mins.

### To View Flow Rate

- Press Menu
- Operational Information – OK
- Scroll down to Heat Pump Details – OK
- Water Flow Level – will show current water flow rate (m<sup>3</sup>/hr).

### To View Alarm History

- Press Menu
- Operational Information – OK
- Scroll Down to Alarm History – OK
- The last 10 alarms will be displayed – most recent alarm at the top, oldest at the bottom.

## Heating Timer

- Push up arrow to highlight C1 - OK
- Select Timer - OK
- Heating (Water) - OK
- (Select Heating Air if T Stat is installed).

### If Simple Timer is selected:

- Frequency - Never / Once / Everyday / Weekends / Work day (Monday - Friday) change to suit
- Starting Time - change to suit
- Mode - Select ECO\*
- Stop Time - change to suit

### \*COMFORT - Normal room temperature set point e.g. 21°C

- ECO - Off set for the temperature set point in timed period e.g. 17°C
- ECO offset value would be 4°C

### If Schedule is selected:

- Timer Configuration - OK
- Select Monday - OK
- Enter Start time (Push up or down arrow)
- Push right arrow - to select on or off
- Push right to select desired temperature set point - OK
- Push down to next line - press OK
- Enter selected times as above
- Push right arrow - select off press OK.

### To copy times to other days - press menu button

- Select copy to other days - OK
  - Select each individual days and press OK on each day
  - Select accept - OK
- 

## To Set ECO Offset Value

- Press Menu
  - System Configuration - OK
  - Space Heating - OK
  - Circuit 1 - OK
  - ECO Offset - change value to suit.
- 

## DHW Timer

- Push right arrow to select DHW - OK
- Select Timer - OK.

### If Simple Timer is selected:

- Frequency - Never / Once / Everyday / Weekends / Work day (Monday - Friday) change to suit
  - Starting Time - change to suit
  - Setting Temperature - change to suit.
  - Stop Time - change to suit.
- 

## T Stat Dead Band

- Press Menu
  - System Configuration - OK
  - General Options - OK
  - Room Thermostats - OK
  - Compensation Factors - OK
  - Circuit 1 - OK
  - Default is 2. Change to 1
  - Press Return twice
  - Room temp demand off - OK
  - Circuit 1 - OK
  - Room Demand off Heat default is 3. Change to 1.
- 

## Contact Details

- Press Menu
  - Scroll to About - OK
  - Contact Information - OK
  - Select letter - OK
  - Change letter to suit - OK
  - Select next letter - OK
  - Repeat as necessary.
- 

## Controller used as T Stat

- Press Return button to scroll between T Stat Screen and Controller Screen
- When on T Stat screen and set point cannot be turned up from 5°C the T Stat is turned off
- Press power button to turn T Stat on.

---

## Summer Switch off - Heating

- Press Menu
- System Configuration - OK
- Optional Functions - OK
- Space Functions - OK
- Heating Auto On/Off - OK
- Change Status to Enabled
- **Choose the temperature you want to unit to stop - default is 22°C**

---

## DHW - Secondary Circulation

- Press Menu
- System Configuration - OK
- Optional Functions - OK
- DHW - OK
- Circuit Pump - change to Enabled
- Press Return twice
- Scroll to I/O and Sensor - OK
- Scroll to Outputs - OK
- Output 1 - change to DHW Re-Circulation.

## 12. Wireless Intelligent Room Thermostat

### 12.1 Safety Summary

#### **⚠ DANGER**

Adhere to the electrical standards in effect, as well as the following points:

- It is imperative to switch off the supply for the sector to which the product will be connected before proceeding to installation. Risk of electric shock.
- Avoid positioning the receiver against or close to any metallic part in order to avoid any radio transmission drop.
- Ensure that there is no dust on the connection points such as the power terminals and / or on the cable. This may cause a fire or electric shock.

#### **⚠ CAUTION**

- Avoid falls and collisions.
- Never attempt to immerse the product in liquid.
- Do not use abrasive products or solvents to clean the casing. Its surface may be cleaned using a soft, dry cloth.
- Do not attempt to open the casing.
- Do not use this product outside. Do not place the connection wire outside.
- All use or modification of the equipment not anticipated by Firebird could lead to danger in using it.
- Use only the cables and accessories supplied.

#### **i NOTE**

- Place the product in a detachable manner close to the device to be controlled. The product should be installed at a height of less than 1.5m high.
- Do not install the gateway where devices using radio frequencies as means of transmission are prohibited (refer to local standards in effect).
- Do not install the gateway close to devices that may be affected by radio waves.
- Do not install the gateway where persons wearing a pacemaker may be present.
- Do not install the gateway in a damp environment (for example, a bathroom).

### 12.2 Factory Supplied Accessories

Description	Quantity
Receiver + Thermostat	1
Screw and plug	2

### 12.3 Installation Information

As these products communicate using RF technology special care must be taken during installation. The location of the RF components as well as the building structure may influence performance of the RF system. To assure system reliability, please review and apply the information given below.

Within a typical residential building the two products should communicate reliably within a 30m range.

It is important to take into consideration that walls and ceilings will reduce the RF signal. The strength of the RF signal reaching the RF Receiver depends on the number of walls and ceilings separating it from the Room Thermostat, as well as the building construction. Walls and ceilings reinforced with steel, or plasterboard walls lined with metal foil reduce the RF signal significantly more.

### 12.4 RF Receiver Installation

- 1 Disconnect the main power from the system. To ensure your safety, always make sure main power is switched off before accessing wiring.
- 2 Remove the cover from the RF receiver.



3 Mount the wiring plate to the wall or wallbox.

**NOTE**

The plugs and mounting screws required are supplied.

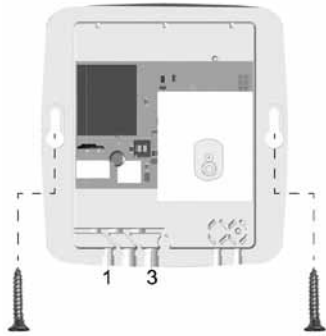

- 4 Connect the RF Receiver wiring.
  - Connect the H-LINK cable.
  - Place the cable through the orifice identified by marker 3.
  - Connect the power cable (L = Live ; N =Neutral) (Tightening torque 0.50 Nm)
  - Place the power cable in the cable guide identified by marker 1.
- 5 The cables must be positioned in the box's cable guides in order to guarantee the pull-off strength.

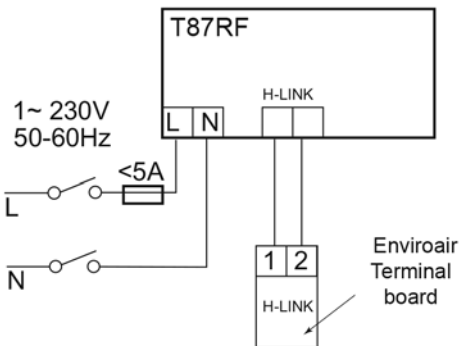

- 6 Attach the cover of the RF receiver to the wiring plate.
- 7 Reconnect the mains power to the system.

**12.4.1 Dimensional data**

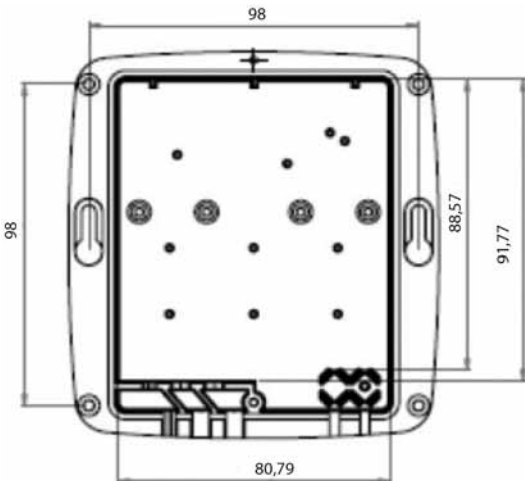

**12.4.2 Description of the parts**

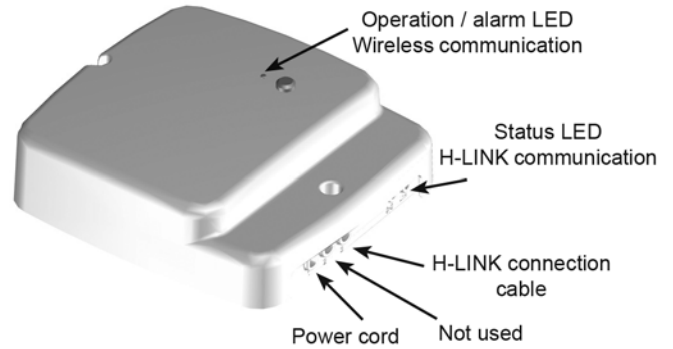

**12.4.3 Technical data**

- Supply voltage: 230V / 50Hz (30mA)
- Wattage: 7W (maximum)
- Dimensions (mm): 123 x 115 x 37
- Weight (g): 214g
- Class 2 reinforced insulation device
- Overvoltage category: Class 2
- Pollution category: Class 2
- Operating Temperature: 0°C to + 60°C
- Operating Humidity: between 30% and 80%
- Equipment protection rating: IP21
- Maximum altitude for use: < 2000m

**12.4.4 Communication**

- Radio
  - Radio frequency: 868MHz - 870Mhz
- H-Link:
  - Communication line: Non-polar, twisted shielded pair cable
  - Communication system: Half-duplex
  - Communication method: Asynchronous
  - Transmission Speed: 9,600 bauds
  - Wiring length: 1,000 m maximum (total length of H-LINK I/O bus)
  - Maximum number of gateways : 1 H-LINK system gateway

**12.4.5 DSW configuration**

Factory setting	
In case of applying high voltage to the terminal 1-2 of TB (Transmitting wires), the fuse on the PCB is cut. In such a case, firstly correct the wiring to TB and then turn ON switch 1 (as shown in the figure)	

### 12.5 Thermostat Installation

- 1 Locate the thermostat
  - Away from draughts
  - Away from heat sources
  - Away from direct sunlight
  - Positioned about 1.2m - 1.5m from the floor

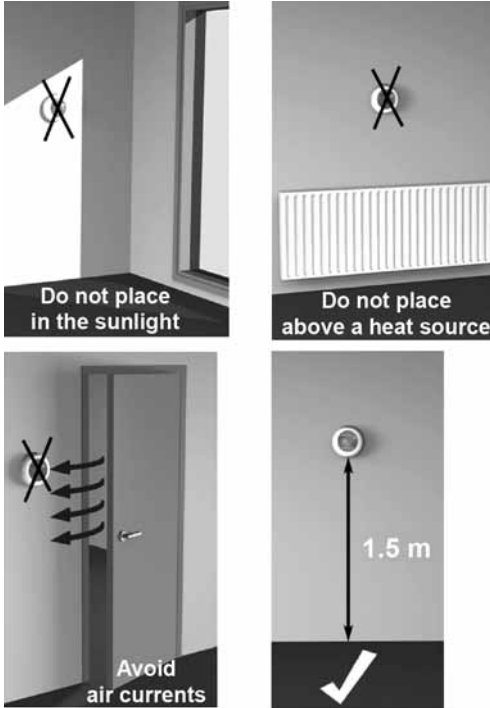

- 2 First remove the dial.



- 3 Unclip the mounting plate.  
Press the top of the thermostat downwards, pull it loose and tilt forwards.



- 4 Mount directly to the wall.  
The plugs and mounting screws required are supplied.

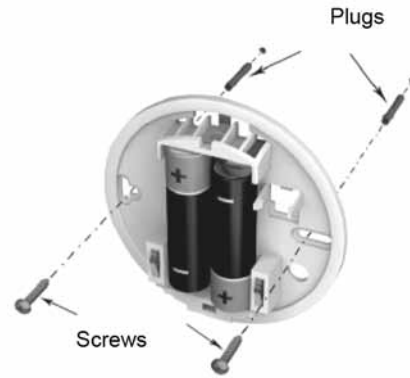

- 5 Remove the protective tab between the batteries.



- 6 Attach the thermostat to the mounting plate.



- 7 Replace the dial.



## 12.6 Operation Instructions

### 2.6.1 RF Receiver

#### Operation / Alarm LED

Green LED flashing	Normal operation
Red LED flashing (0.1s ON, 3s OFF)	Communication fault between room thermostat and RF Receiver
Red LED flashing quickly 3 times	Faulty device
BIND LED (ON and OFF 0.5 seconds)	Binding process

#### Status LED

Green LED lit	Normal operation
Green LED flashing	Communication fault between room thermostat and RF Receiver

#### Reset

To reset the stored data in order to create a new binding in ASH000AWT press BIND button during 15 seconds.

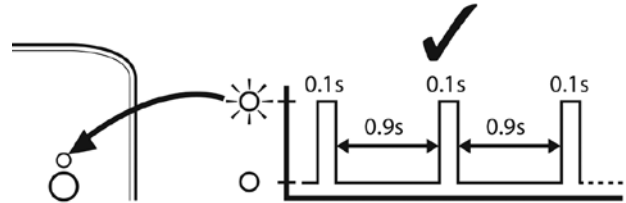

### 12.6.2 Thermostat

#### Explanation of the icons

	<b>Setting temperature</b> The figure appearing on the screen corresponds to the setting temperature, instead of the current room temperature.
	<b>Heating on</b> Heating is demanding, and thus the heat pump should be in operation, either intermittent or continuous.
	<b>RF Receiver connection</b> The thermostat is successfully connected to the RF Receiver.
	<b>Low battery</b> It is necessary to replace the batteries immediately.
	<b>RF communication error</b> These icons flash to indicate that the signal from the RF Receiver is not properly received. Check that the RF Receiver is powered on, and consult with your installer if this does not fix the problem.
	<b>Defective thermostat</b> The thermostat is defective and needs to be replaced  The text <i>F77</i> is displayed in addition to this icon when communication with the Enviroair unit has failed for more than 180 seconds.
	<b>No power to the thermostat</b> If the thermostat screen appears blank after initial installation, then check whether the protective film has been removed from the batteries. Otherwise, try replacing the batteries.

#### Setting of room temperature

The current room temperature is shown in the display. The setting temperature can be changed by turning the dial to the right to increase temperature, and to the left to reduce temperature. The setting temperature changes in 0.5 °C steps, one for each 'click' as the dial is turned.



The display changes to current room temperature again after five seconds have passed. Then the thermostat tries to maintain the set temperature as accurately as possible. The setting temperature can be checked by turning the dial one 'click' to the left or right. It will flash up for a few seconds, before returning to the display of room temperature again.

#### Night temperature reduction

It is recommended to set the thermostat to a lower temperature at night and during absence periods, as it helps to save energy. In general a reduction of 5 °C is suggested, but this depends on the heating system and the amount of insulation of the building

#### Installation menu

The single zone thermostat has an installation menu that is used to set the maximum and minimum temperature limits. The maximum temperature that can be set on the thermostat is 35 °C and the minimum temperature is 5 °C.

### 12.6.2 Thermostat (cont.)

#### ON / OFF Switch

The temperature dial is used to turn the system ON and OFF. Turn the dial to the left until the displayed temperature is 10 °C or lower in order to turn the system off. Turn the dial to the right until the displayed temperature is more than 10 °C in order to turn the system ON again.

#### Activation of the installation menu

Rotate the setting ring fully to the left until the minimum value is shown. When the value starts flashing, touch and hold on left or right touch zones for approximately 10 s.



The maximum temperature limit is now displayed. The setting can be changed using the setting ring. There is no need to confirm the value.



While this setting is flashing, touch the left touch zone briefly to display the minimum temperature limit. This can also be changed using the setting ring.



The thermostat cannot be used to turn the system on and off unless the limit for minimum temperature is set to a value lower than 11 °C (Ex: 5 °C)

The installation menu is closed automatically after 10 seconds of inactivity.

#### Reset to default

Rotate the setting ring fully to the left until the minimum temperature is shown.

When the value starts flashing, touch and hold on left and right touch zones for approximately 10s. The maximum temperature limit is now displayed flashing, touch the left touch zone briefly.

When the minimum temperature limit is flashing, touch the left touch zone again.

The symbol appears on the screen. Touch and hold the left touch zone for 10s and the device resets the default settings.

## 12.7 Binding the Wireless Thermostat and RF Receiver

The binding operation described below is required if:

- Any of the system components (Room Thermostat or RF Receiver) are replaced.
- The RF Receiver has incorrect or no binding data stored (e.g. when pre-bound system pack components have been mismatched).

### NOTE

During the binding procedure keep approximately 1m distance between the Room Thermostat and the RF Receiver.

- 1 Hold button on RF Receiver for 15 seconds in order to remove all the configurations. LED will flash red 0.1 sec ON, and 0.9 sec OFF.
- 2 Hold button on RF Receiver for 5 seconds. LED will flash red for 0.5 sec ON, and 0.5 sec OFF.

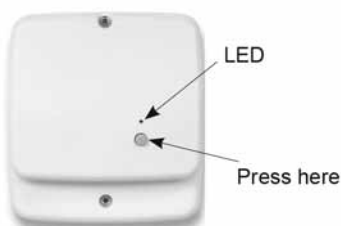

- 3 Bind the thermostat. Touch and hold on the left touch zone for approximately 10 seconds.



- 4 The screen for binding the RF Receiver is now displayed.



- 5 When the symbol "bo" is flashing, rotate the setting ring until the "Co" symbol is shown.



- 6 Briefly touch the left touch zone to send the binding signal, at which point the symbol will flash several times.

- 7 If binding has been successful the number indicates the signal strength (1 = min to 5 = max). If binding fails,  appears on screen. Please try again.



Successful binding



Failed binding

- 8 The green LED on the RF Receiver will flash green every 10 seconds to indicate that the device is live.

**i NOTE**

Binding can be cancelled from the binding screen by touching and holding on the left touch zone for approximately 10 seconds.

- 9 If binding is unsuccessful, then the LED will stay on. In this case, move the room thermostat and repeat the procedure from the beginning.

- 10 To bind the second room thermostat, repeat the procedure from step 2 to 8 to bind the second room thermostat.

**i NOTE**

- The first binding is saved as Thermostat 1, and the second binding (if necessary) is saved as Thermostat 2.
- The selection of the zone in which Room thermostat will be used is done at the Room thermostat menu in the Controller.

**12.8 Replacement of the Batteries**

- 1 Pull to remove the dial ring.
- 2 Detach the thermostat from the base.
- 3 Replace the batteries as shown at the picture.
- 4 Attach the thermostat to the base.
- 5 Replace the dial ring.



**12.9 Communication Loss**

In the event of an RF communications loss, the LED on the RF Receiver will indicate which type of fault has occurred.

- If there is a communications fault between the RF Receiver and the Room Thermostat, then the LED on the RF Receiver will flash red for 0.1 sec ON every three seconds.
- If there is a fault in communications between the Firebird Heat Pump and RF Receiver, then the LED on the RF Receiver will flash red 3 times quickly and then be off for three seconds.

- If there is more than one Room Unit installed, as in multi-zone systems for example, and communications is lost with one zone, then the red LED on the RF Receiver will flash two times quickly and then be off for two seconds.
- If there is more than one Room Unit installed, as in multi-zone systems for example, and communications is lost with both zones, then the red LED on the RF Receiver will flash once for 0.1 sec ON, and 0.9 sec OFF.

Once the faulty device has been identified, replace as necessary and follow the re-binding procedure as described in section "3 Binding the Wireless thermostat and RF Receiver".

**12.10 Fail-Safe Mode Setup**

The fail-safe mode defines the system status if the RF communication is lost (e.g. when the room thermostat stops communicating due to discharged batteries).

The system will continue to operate at the last communicated set point.

**12.11 Troubleshooting**

Symptom (fault message)	Possible cause	Remedy
The receiver box does not react to set point changes on the room thermostat.	The room thermostat and receiver box are not bound.	Reset the receiver box by pressing and holding the push button for 15 seconds. Then follow the binding / rebinding procedure as described in section "3 Binding the Wireless thermostat and RF Receiver".
The red LED is on the receiver box (communication loss)	The receiver box receives no RF messages from the room thermostat: RF signal is blocked due to wrong location of the room thermostat. Room thermostat batteries are exhausted.	Re-locate the room thermostat. Replace batteries in the room thermostat.

## 13. Main Safety Devices

### Compressor protection

High Pressure Switch:

This switch cuts out the operation of the compressor when the discharge pressure exceeds the setting.

### Fan motor protection

When the thermistor temperature is reached to the setting, motor output is decreased.

Alternatively, when the temperature becomes lower, limitation is cancelled.

Model			Enviroair 7.5kW	Enviroair 11 - 16kW
For compressor				
Pressure switches		-	Automatic reset, non-adjustable (each one for each compressor)	
High	Cut-out	MPa	4.15	
	Cut-in	MPa	3.20	
Low for control	Cut-out	MPa	0.30	
	Cut-in	MPa	0.20	
Fuse		-		
1- 230V 50Hz		A	40	50
CCP timer		-	Non-adjustable	
Setting time		Min.	3	
For condenser fan motor Internal thermostat		-	Automatic reset, non-adjustable (each one for each motor)	
For control circuit Fuse on PCB		A	5	

# 14. Hybrid Systems

Enviroair air source heat pumps can be installed in conjunction with a traditional oil-fired or gas-fired boiler to create a hybrid system (see hydraulic schematic and electrical configuration).

Providing all design considerations have been followed, the heat pump/ boiler combination will provide system flexibility and comfort during extreme climatic conditions.

All diverter valves and sensors are operated by the Enviroair heat pump controls when the required parameters (including bivalent point) are reached.

## **i** NOTE

*The boiler will only operate if the Enviroair heat pump controls are set to **Space Heating** and/or **DHW** mode. The boiler will be disabled for any other function (swimming pool configuration).*

### 14.1 Controller Setting

The boiler will only operate if set to HP (Heat Pump) + Boiler during initial set up and commissioning phase. The heat pump and boiler can never work at the same time. The decision on when the boiler will take over operation is dependent on the set bivalent point (see “10. Commissioning”).

### 14.2 Bivalent Point

It is always recommended that during the initial design phase the heat pump is designed to operate down to the lowest geographical ambient temperature for the area of installation. As heat pump capacity reduces with temperature a point may be reached where the heat pump capacity will be insufficient to provide demand during extreme climatic conditions. This parameter is called the Bivalent Point and is set on the heat pump controller during first commissioning. The Bivalent / Balance Point should be calculated according to design specification and known before installation commences. When this parameter is reached the boiler will take over DHW / Space Heating functions. When the ambient temperature rises, the boiler will automatically ‘Switch out’ and DHW / Space Heating functions will be resumed by the heat pump.

### 14.3 Parallel Operation

When used in a Hybrid System it is imperative that the system is run in a ‘Parallel’ configuration with a buffer tank (see hydraulic schematic) and sensor Two3 is set up accordingly through controller settings (see “11. Unit Controller”).

### 14.4 Operating Conditions

Space Heating and/or DHW mode selected.

- Boiler Complementary Heating selected on controller.
- Boiler in ‘Parallel Operation’
- Ambient temperature < Set Bivalent Point.

### 14.5 Configuration

	Default	Range
Bivalent Point	-5°C	-20 to 20°C
Supply Offset Temperature	4°C	0 to 10°C
Waiting Time (Space Heating)*	30 min	5 to 90 min
Waiting Time (DHW)*	45 min	Off, 5 to 120 min

\* The time that the heat pump control circuits will ‘wait’ before activating in the boiler. This prevents operation during short periods of ambient temperature drop.

## **i** NOTE

*In the unlikely occurrence of a heat pump breakdown, the controls can be overridden by use of the **EMERGENCY** Mode switch. This will activate the boiler.*

### 14.6 Suggested Hydraulic Layout with Underfloor Circuit

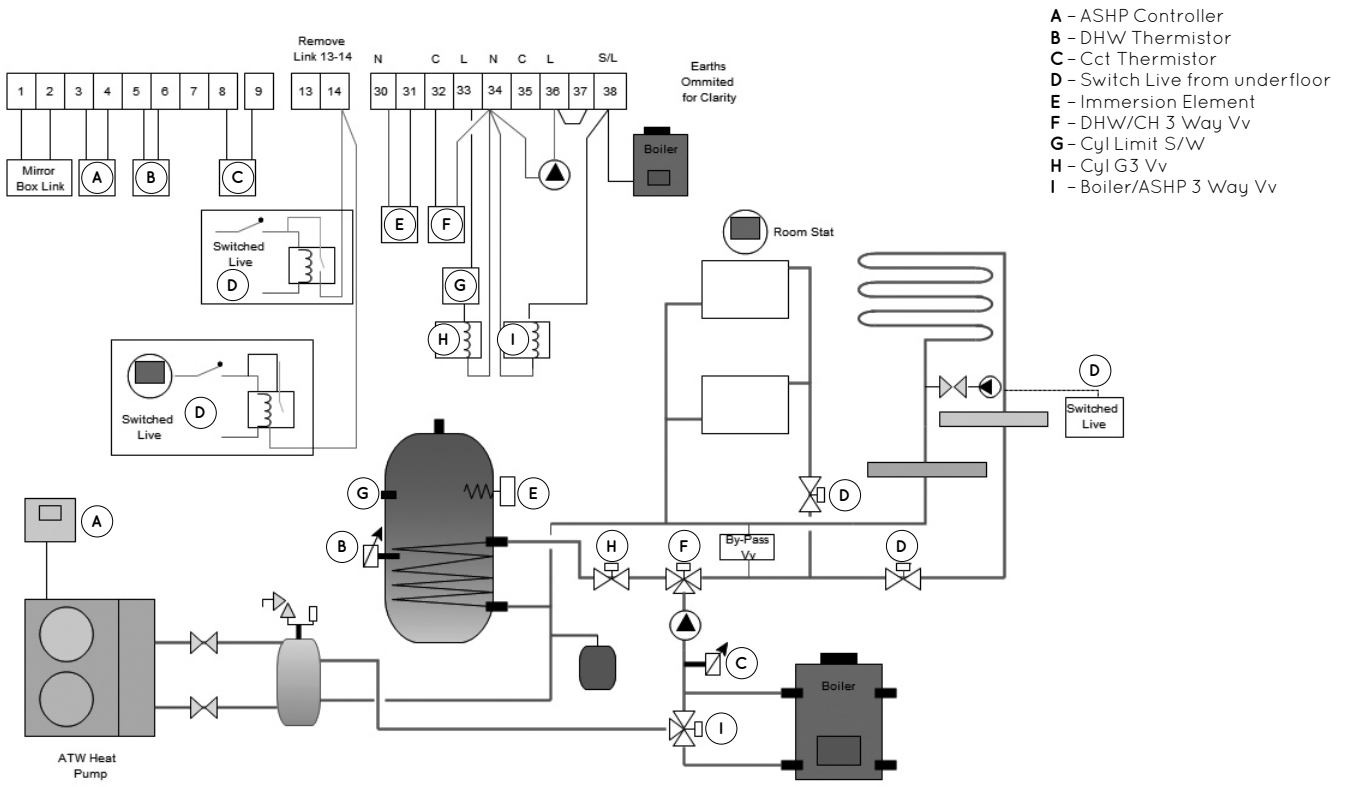

### 14.7 Suggested Hydraulic Layout with Radiator / Underfloor Circuit

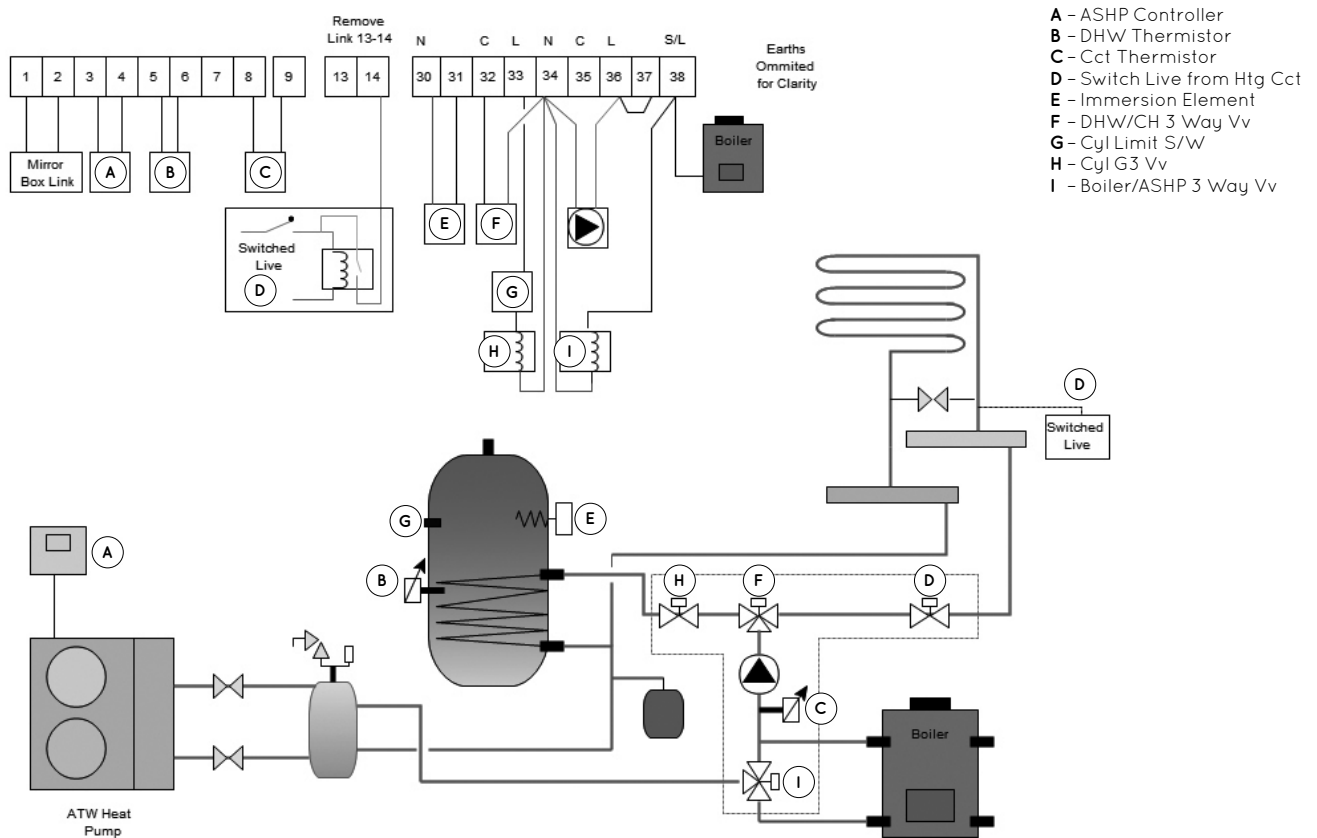

### 14.8 Suggested Hydraulic Layout with Radiator Circuit when DHW Supplied by a Combi Boiler

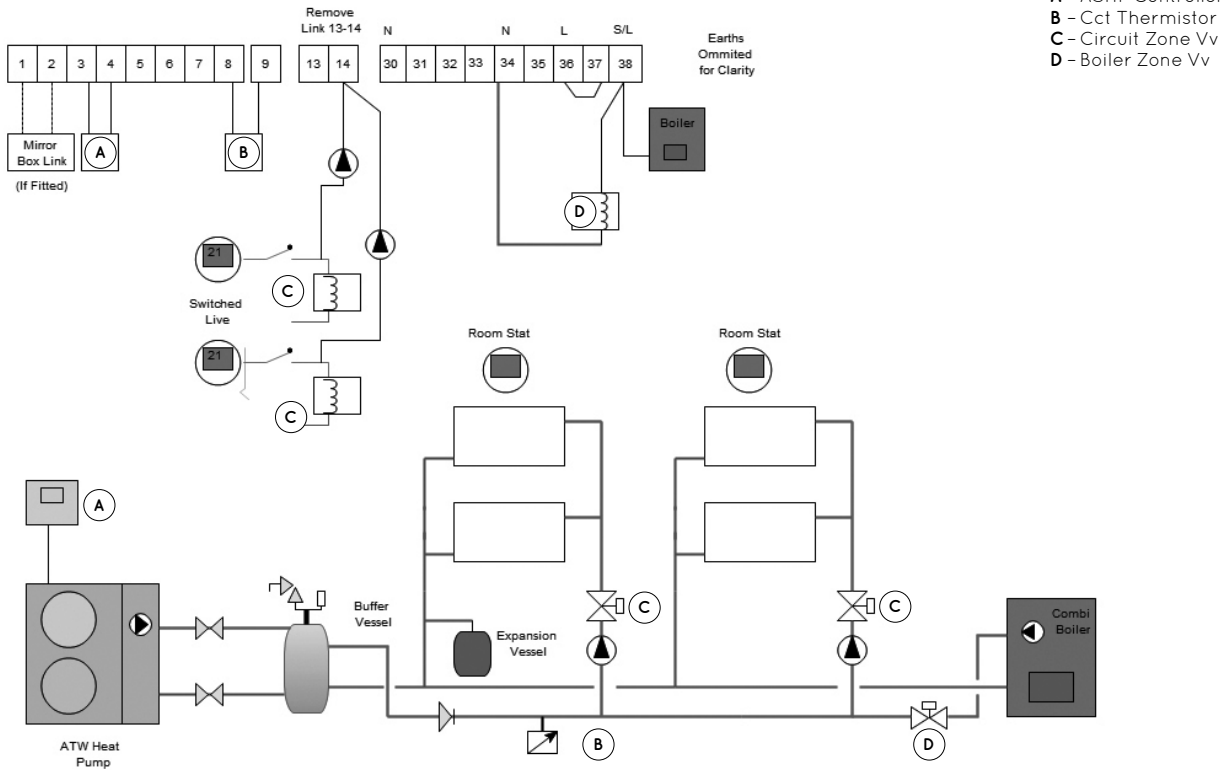

### 14.9 Suggested Hydraulic Layout with Underfloor Heating Circuit when DHW Supplied by a Combi Boiler

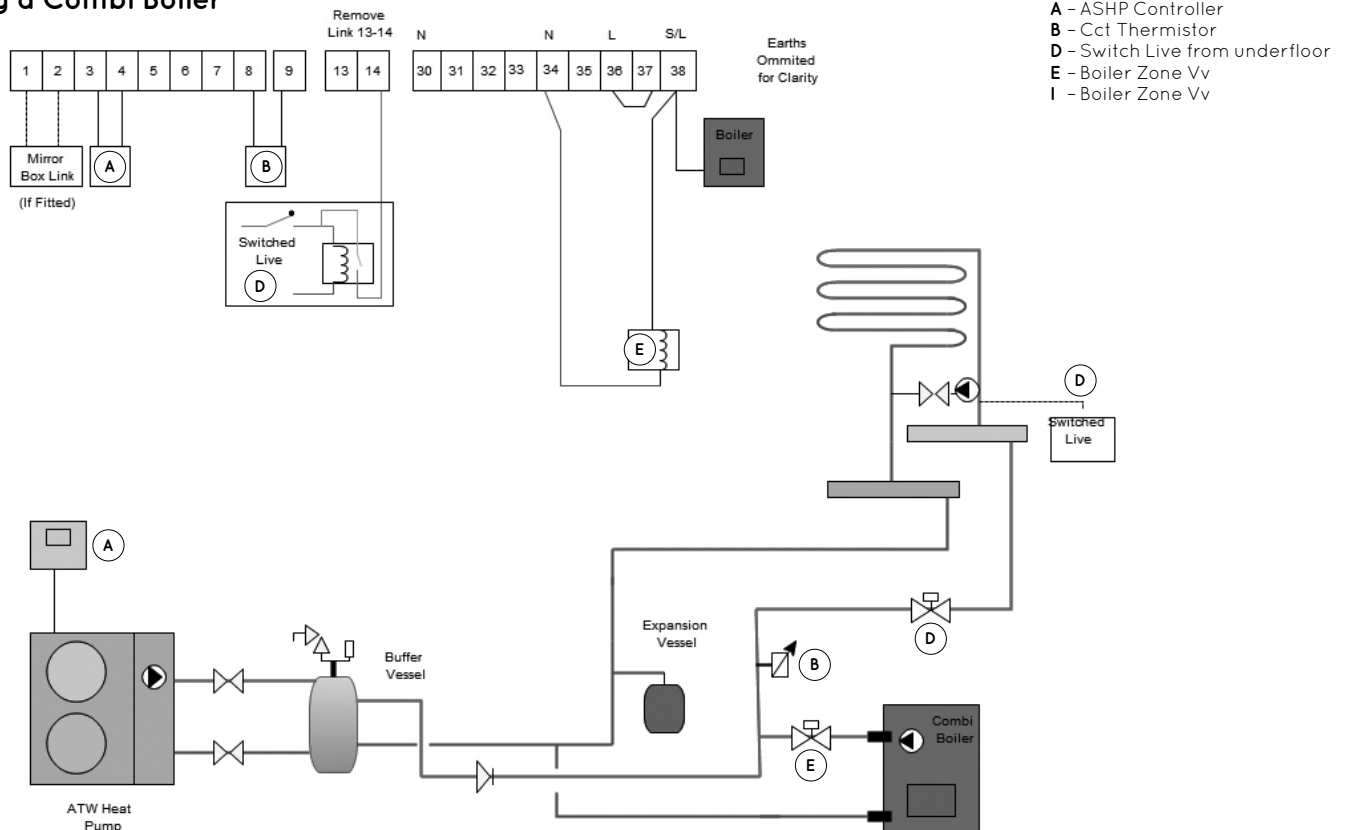

## 15. Troubleshooting

### Alarm codes for the outdoor and indoor units

Alarm Code	Retry stop*	Enviroair	Origin	Detail of Abnormality	Main Factors
3	-	0	Transmission	Transmission alarm (not outdoor unit detected)	Loose, disconnected, broken or short-circuited connector
11	-	0	Indoor	Water inlet thermistor anomaly (THMwi)	Loose, disconnected, broken or short-circuited connector
12	-	0	Indoor	Water outlet thermistor anomaly (THMwo)	Loose, disconnected, broken or short-circuited connector
13	-	0	Indoor	Indoor liquid pipe temp thermistor anomaly (THMI)	Loose, disconnected, broken or short-circuited connector
14	-	0	Indoor	Indoor gas pipe temp thermistor anomaly (THMg)	Loose, disconnected, broken or short-circuited connector
15	-	(0)	Indoor	Water circuit 2 thermistor anomaly (THMwo2)	Loose, disconnected, broken or short-circuited connector
16	-	(0)	Indoor	Water DHW thermistor anomaly (THMdhwt)	Loose, disconnected, broken or short-circuited connector
17	-	(0)	Indoor	Auxiliary sensor 2 thermistor anomaly (THMaux2)	Loose, disconnected, broken or short-circuited connector
18	-	(0)	Indoor	Auxiliary sensor 1 thermistor anomaly (THMaux1)	Loose, disconnected, broken or short-circuited connector
25	-	(0)	Indoor	Auxiliary sensor 3 thermistor anomaly (THMaux3)	Loose, disconnected, broken or short-circuited connector
40	-	0	Indoor	Incorrect Unit controller setting	Current Unit controller configuration does not allow proper operation
70	P70	0	Indoor	Hydraulic alarm flow and Water Pump malfunction	Water low is not detected in the hydraulic cycle or Pump defective
73	-	0	Indoor	Mixing over-temperature limit protection for mixed circuit	Circuit 2 supply temperature > Target temperature + offset
74	P74	0	Indoor	Unit over-temperature limit protection	Two > Tmax +5K
75	-	0	Indoor	Freeze Protection by cold water inlet, outlet temperature detection	

\*Protection codes where if displayed, the unit will try and restart three times under this alarm code and on the third attempt the unit will stop.

Alarm Code	Retry stop*	Enviroair	Origin	Detail of Abnormality	Main Factors
76	-	0	Indoor	Freeze Protection stop by indoor liquid temperature thermistor	
77	-	0	Indoor - Unit Controller	Receiver Communication failure	No Opentherm / Hlink communication for a continuous period of 10 minutes
78	-	0	Indoor - Unit Controller	RF Communication failure	There is no communication for 1 hour with on or two RF receivers which are bound to the RF-Bridge.
79	-	0	Indoor - Outdoor	Unit Capacity setting error	There is no concordance between indoor outdoor unit capacity
80	-	0	Indoor - Unit Controller	Unit controller - H-link - RCS transmission error (if no H-LINK, RCS has no power)	No H-link communication for a continuous period of 1 minute between Indoor and Unit controller User control by connection wiring (breaking, wiring error, etc.)
81	P81	0	Indoor	"Momentary Power interruption" or "Low voltage detected"	
83	P83	0	Indoor	Hydraulic alarm pressure	Water pressure is not detected in the hydraulic cycle
157		(0)	Indoor	Inverter communication abnormality thermistor	Described in inverter abnormal stop control
202		(0)	Indoor	Wrong settings of Controller	
203		(0)	Indoor	Slave PC-ARFHE stops answering to Master Controller	Loose, disconnected, broken or short-circuited connector
204		(0)	Indoor	Indoor unit stops answering to Master Controller	Loose, disconnected, broken or short-circuited connector

**i NOTE**

(0): Option configurable from Unit controller. This alarm will be displayed if the system has been configured.

0: Default. This alarm will be displayed in the Unit controller.

-: Not applicable.

\*Protection codes where if displayed, the unit will try and restart three times under this alarm code and on the third attempt the unit will stop.





*An rogha is fearr*

**FIREBIRD**



**HEATING SOLUTIONS**

**Firebird Heating Solutions Ltd.**  
Údarás Industrial Estate,  
Baile Mhic Íre, Co. Cork,  
Ireland,  
P12 HK51.

t: +353 (0)26 45253  
f: +353 (0)26 45309  
e: [info@firebird.ie](mailto:info@firebird.ie)  
[www.firebird.ie](http://www.firebird.ie)

**Firebird Heating Solutions Ltd.**  
Shean, Forkhill,  
Newry,  
BT35 9SY.

t: +44 (0)28 3088 8330  
f: +44 (0)28 3088 9096  
e: [firebirdproducts@hotmail.co.uk](mailto:firebirdproducts@hotmail.co.uk)  
[www.firebird.ie](http://www.firebird.ie)

**Firebird Products Ltd,**  
Phoenix House,  
Eastern Wood Road,  
Langage Industrial Estate,  
Plympton,  
Plymouth PL7 5ET.

t: +44 (0)1752 691177  
f: +44 (0)1752 691131  
e: [sales@firebird.uk.com](mailto:sales@firebird.uk.com)  
[www.firebird.uk.com](http://www.firebird.uk.com)

MLEHP000

This brochure was correct at the time of going to print. However, Firebird's policy is one of continuous development. The right is reserved to change specifications, colour, and prices of the models and items illustrated and described in the publication at any time. Whilst every care has been exercised in the production of this brochure, Firebird cannot accept any liability for errors or omissions. For current details always consult Firebird Products Ltd.



ENVIRONMENT



INNOVATION



TECHNOLOGY

